

**WATER AND HERBICIDE MOVEMENT IN A GHANAIAN FIELD SOIL UNDER
VARYING IRRIGATION FREQUENCY.**

BY



**A THESIS SUBMITTED TO THE DEPARTMENT OF SOIL SCIENCE, UNIVERSITY
OF GHANA, IN PARTIAL FULFILMENT OF THE REQUIREMENT FOR THE
MASTER OF PHILOSOPHY (M.Phil.) DEGREE IN SOIL SCIENCE.**

SEPTEMBER, 1996.



G350273
S599.SG4 Am7
Utc C.1

DEDICATION

Dedicated to Christiana and Manuela



DECLARATION

I hereby declare that, except for references to works of other researchers which have been cited, this work is the result of my own original research and that this thesis has neither in whole nor part been presented to any other University for the award of a degree.

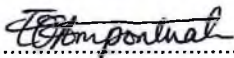
.....

Emmanuel Osei Ampontuah
(Student)

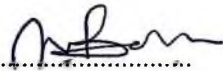

.....

Dr. Mensah Bonsu
(Supervisor)

.....

Mr. Mahama Seidu
(Supervisor)

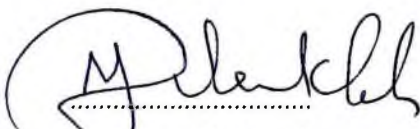

.....

Prof. Yaw Ahenkorah
(Supervisor)

ABSTRACT

This study reports an investigation of the influence of irrigation frequency on water and herbicide transport in a Ghanaian field soil. An attempt was also made at simulating the movements of water and atrazine [2-chloro-4-ethylamino-6-isopropylamino-*s*-triazine] in the soil under varying irrigation frequency. The irrigation treatments used in the study were: Treatment 1 (T1): 150 mm of water applied in three equal amounts of 50 mm each on days 1, 9 and 17; Treatment 2 (T2): 150 mm of water applied in five equal amounts of 30 mm each on days 1, 5, 9, 13 and 17; and Treatment 3 (T3): 150 mm of water applied in nine equal amounts of 16.6 mm each on days 1, 3, 5, 7, 9, 11, 13, 15 and 17 after the commencement of the experiment. Furthermore, the differences in water storage under the different irrigation treatments were also investigated.

In general, T2 resulted in highest water storage at the end of the experiment, followed by T1 and then T3. Water loss from the profile was in the reverse order. Treatment 1 caused more leaching of atrazine and the centres of mass of atrazine at the end of the experiment were in the order $T1 > T2 \approx T3$. Sorption of atrazine decreased with depth. The percentage of atrazine recovered decreased linearly with time and the amounts of the herbicide recovered at the end of the experiment were in the order $T2 > T1 \approx T3$. Thus treatments 1 and 3 resulted in greater loss of atrazine probably due to deep percolation resulting from the relatively higher amounts of water applied and partly due to volatilization, respectively.

The simulated water profiles compared favourably with the field-measured ones especially in T1 and T3 (with R^2 values of 0.754 and 0.674, respectively). In all the treatments, the predicted water contents were higher in the top 0.3 m than the observed values. However, using 1:1 plots, it

was noted that the simulated water content values were in good agreement with the measured ones especially at the initial stages of the experiments. The deviations of the predicted values from the observed became more apparent with subsequent water applications. The inability of the model to correctly predict well was ascribed to its simplicity, neglecting the effects of hysteresis during water redistribution and the type of simplified numerical scheme used to solve the water flow equation.

The patterns of the observed and predicted solute fronts were in good agreement. Using a Chi-square test, it was found that differences between the observed and predicted leaching fronts were not significantly different at 1% level.

ACKNOWLEDGEMENTS

I wish to express my profound gratitude to my supervisors Dr. Mensah Bonsu, Prof. Yaw Ahenkorah and Mr. Mahama Seidu for their relentless effort in getting this work to a triumphant end. Special mention must be made of Prof. Ahenkorah who always searched for money to purchase chemicals for me when the Department had no money. My special thanks go to Dr. S.G.K. Adiku (Uncle Sam) for suggesting the research area, his guidance in writing this thesis, and helping in the computer programming. Uncle Sam, where would I have been, and what would I have done if you had not come in time? Thank you very much. As you rightly said of a teacher, your reward is in heaven. God richly bless you.

I am also grateful to the other lecturers at the Department of Soil Science especially Dr. G.N.N. Dowuona, Dr. S. Duah-Yentumi, Dr. J.K. Amatekpor and Dr. E. Owusu-Bennoah for their advice and encouragement during the course of this research. My thanks to Dr. B.K. Ahunu (the former Dean) for renewing my teaching assistantship for a second term. Thank you Sir.

It is my wish to say a big thank you to Christie (my wife), Manuela (my daughter) and Maame Yaa (my sister) for their patience and deep sense of understanding during the long hours of my absence from home. Thanks a lot.

I am deeply indebted to Mr. Thomas Armah (my uncle) for helping me financially throughout this course. Thanks also to Mr. Isaac Tete-Mensah (T. Mens) for his financial help during the first year of this course.

I also wish to thank all the technicians, co-teaching assistants, the librarian and the drivers at the Soil Science Department for their help. They are Boss Sarquah, Uncle J., Father Aggrey,

Theo, Mr. Adusei, Alhaji, Wisdom, Master Arku, Mr. Ashia and Mr. Ohemeng. My special gratitude to Ahmed Osumanu Haruna (Alhaji) for his readily available help.

I cannot forget the "You guys", "My friend" and "Pourquoi" colleagues - Nartey, Kofi, Osei-Wusu, Safohen, Abu, E.K., Joe, Yeboah, ~~Franko-Lilly~~ and Leo. It was great to have you guys around.

My sincere thanks to the organizers of the University of California/University of Ghana Education Abroad Programme and most especially to Prof. Dennis Rolston of the Department of Land, Air and Water Resources (U.C. Davis) for providing me with a laboratory space and assistantship during the course of the programme. Thanks also to the Rolston Family and my lab mates for making my one-year stay in Davis very enjoyable.

Finally, MAY THE NAME OF THE LORD BE PRAISED. TO HIM BE THE GLORY.

TABLE OF CONTENT

	Page
Dedication	i
Declaration	ii
Abstract	iii
Acknowledgement	v
Table of content	vii
List of Tables	xi
List of Figures	xii
CHAPTER 1	
1.0 INTRODUCTION	1
1.1 Background	1
1.2 Problem specification	2
CHAPTER 2	
2.0 LITERATURE REVIEW	5
2.1. Importance of herbicide use in the tropics	5
2.2 The fate of herbicides in soils	6
2.2.1. Transport of herbicides	8
2.2.1.1 Runoff and Leaching	8
2.2.1.2 Properties of the herbicide that influence leaching losses	9
2.2.1.3 Effects of soil properties on herbicide leaching.	10
2.2.1.4 Some soil management procedures that affect herbicide leaching.	12
2.2.1.5 Influence of irrigation technology on herbicide leaching.	14

2.2.2	Pesticide-soil interaction	16
2.2.2.1	Adsorption	16
2.2.3	Herbicide degradation in soils	21
2.2.3.1	Microbial degradation	21
2.2.3.2	Chemical degradation	23
2.2.3.3	Photodecomposition	25
2.2.4	Plant uptake	25
2.2.5	Volatilization of herbicides	26
2.3	Modelling the movement of herbicides in soil	28
2.3.1	The Burns' Leaching Equation	28
2.3.2	The Convective-dispersion equation	31
2.3.2.1	Diffusion	31
2.3.2.2	Mass flow	33
CHAPTER 3		
3.0	MATERIALS AND METHODOLOGY	36
3.1	Experimental Site	36
3.1.1	Location and Climate	36
3.1.2	Soils	36
3.2	Site preparation, experimental layout and treatments.	38
3.3	Application of atrazine	39
3.4	Irrigation application	40
3.5	Soil sampling, extraction and atrazine residue analysis	40
3.5.1	Spectrophotometric Reading and Calculation of Atrazine concentration	42

3.6. Determination of physico-chemical properties	43
3.6.1. Soil texture	43
3.6.2. Bulk density	43
3.6.3. Soil pH and organic carbon	43
3.6.4. Saturated hydraulic conductivity	44
3.7 Determination of adsorption atrazine by soils	45
3.8 Atrazine recovery and dissipation	46
3.9 Soil water measurements	47
3.9.1 Soil water storage	47
CHAPTER 4	
4.0 RESULTS AND DISCUSSION	49
4.1 Soil chemical and physical properties	49
4.2 Soil water distribution under the different irrigation treatments	51
4.3 Soil water storage	55
4.4 Losses of soil water	58
4.5 Atrazine transport in soils	60
4.5.1 Atrazine distribution in soils	60
4.5.2 Comparison of atrazine movement in the various treatments	64
4.6 Factors affecting atrazine movement.	66
4.6.1 Atrazine sorption	66
4.6.2 Atrazine recovery and dissipation.	67

CHAPTER 5

5.0	MODELLING TRANSPORT OF WATER AND ATRAZINE IN A FIELD SOIL.	73
5.1	Introduction	73
5.2	Materials and methods	74
5.2.1	Theoretical Framework for describing water flow in soils	74
5.2.2	Modelling solute transport	77
5.2.3	Some soil properties used in the simulations	79
5.2.4	Data sources	79
5.3	Results and discussion	80
5.3.1	Prediction of water movement and moisture profiles	80
5.3.2	Prediction of atrazine front within the soil profile	89

CHAPTER 6

6.0	CONCLUSIONS AND RECOMMENDATIONS	92
-----	---	----

CHAPTER 7

7.0	SUMMARY	93
	REFERENCES	95
	APPENDICES	110

LIST OF TABLES

3.1	Description of irrigation treatments studied	38
3.2	Neutron probe calibration equation for the various soil depths	47
4.1	Some physico-chemical properties of the soil	49
5.1	The soil properties used in the simulations	79
5.2	Comparison of predicted and measured depths (m) of leaching of atrazine on various of sampling	90

LIST OF FIGURES

2.1	Introduction and fate of herbicides in the environment	7
3.1	Mean monthly rainfall and temperature for Accra	37
3.2	A schematic presentation of the layout of plots on the field	39
4.1	The variation of bulk density with depth	50
4.2	Variation of soil moisture profiles under "Low Frequency Irrigation" (T1)	52
4.3	Variation of soil moisture profiles under "Medium Frequency Irrigation" (T2)	52
4.4	Variation of soil moisture profiles under "High Frequency Irrigation" (T3)	54
4.5	Cummulative change in water storage within the soil profile	56
4.6	Water loss under the various treatments from the soil profile	59
4.7	Distribution of atrazine in the soil within the first week of application	61
4.8	Distribution of atrazine in the soil, 15 and 22 days after application	62
4.9	Relationship between irrigation frequency and atrazine movement	65
4.10	The adsorption isotherms for atrazine at 0-0.2 m and 0.2-0.4 m depths	68
4.11	Relationship between per cent mass of atrazine within the soil profile and irrigation treatments.	70
4.12	Dynamics of atrazine dissipation in soil	71
5.1	Scheme for calculating soil water flow	76
5.2	Simulation of water movement under "Low Frequency Irrigation" (T1)	81
5.3	Simulation of water movement under "Medium Frequency Irrigation" (T2)	82
5.4	Simulation of water movement under "High Frequency Irrigation" (T3)	84
5.5	Relationship between the observed and predicted water contents under T1	85

5.6	Relationship between the observed and predicted water contents under T2	86
5.7	Relationship between the observed and predicted water contents under T3	87

CHAPTER ONE

1.0 INTRODUCTION

1.1 Background

One very significant challenge facing the production agronomist is the development of a satisfactory management technique that combines optimum crop production with environmental protection. Although improved crop production has been achieved by effective pest control through the use of pesticides, their continual use has become a worldwide concern due to their effects on the environment (i.e. groundwater and atmospheric pollution). To minimise these adverse effects, limits on the use of some pesticides and other agrochemicals have, therefore, been legislated in several developed countries where they have been mostly used (Byrnes, 1990; Shepherd *et al.*, 1993). In many developing countries, there is also a trend of increasing use of agrochemicals to ensure high crop production. However, the question of the appropriate application limits is far from resolved.

The determination of limits on pesticide use may be based on physico-chemical properties of soils on which they are used, persistence characteristics of the pesticide and some knowledge on the transport processes that affect the movement of such chemicals in the soil. In many developing countries, such basic data on pesticide movement and pesticide-soil interaction are generally lacking. This is an obstacle to the formulation of application limits. While it may be argued that manufacturers recommendations are given on the packages, these may not be appropriate especially under the apparently warm climates that exist in the tropics. Considering also the poor chemical retention properties of most tropical soils, leaching losses of the chemicals can be high. Thus, the need to monitor, on continuous basis, the effect of the increasing use of agrochemicals on soil and

groundwater quality in Ghana has been emphasised (Ahenkorah *et al.*, 1994) .

1.2 Problem specification

Useful insight into the manner in which soil and groundwater pollution by pesticides occurs may begin with an understanding of the fate and processes of pesticide transport in soils. When a pesticide is applied directly to the soil or to a crop (which eventually ends up in the soil) it may be adsorbed, transported, taken up by plants, volatilized or degraded. Of all these processes the transport and the volatilization seem to exert the greatest influence on the pollution of the environment. Movement of a pesticide in the soil environment may occur while in solution or adsorbed on migrating particulate matter, or by volatilization (Khan, 1980). Some factors that may affect transport of pesticides in soils include soil management techniques such as tillage (Gish *et al.*, 1995; Isensee and Sadeghi, 1994; Hall *et al.*, 1989; Dick *et al.*, 1989), rainfall intensity (Edwards *et al.*, 1992; Sigua *et al.*, 1992), rainfall or irrigation amount (Troiano *et al.*, 1993), initial soil water content (White *et al.*, 1986) and soil water management (Cassel, 1971).

Since transport (leaching) of pesticides in soil is associated with water movement, it may seem obvious that different amounts of deep percolating water would also result in differences in amounts of leached pesticides. Yaron *et al.* (1985) noted in the particular case of irrigated agriculture that the type of irrigation technology can lead to differences in pesticide leaching. Troiano *et al.* (1993) found that the magnitude of leaching increased in the order: sprinkler < basin < furrow.

It is, however, conceivable that differences in the extent of pesticide leaching may also exist as a result of varying the irrigation frequency while maintaining the same depth of water application.

This aspect of pesticide leaching seems to be less studied. Similar studies on the effect of varying irrigation frequencies on the transport of inorganic solutes have not led to any conclusive results. For instance, Alva *et al.* (1990) studied the leaching of cations in a loamy sand and sandy soils as influenced by irrigation frequency. In both soils, leaching of Ca below the pod-forming zone of the (groundnut) crop studied was significantly greater for the low frequency irrigation treatments than for the high frequency treatments. This is contrary to the findings of Miller *et al.* (1965) who studied the movement of KCl as affected by continuous ponding and intermittent irrigation. It was found that the latter treatment resulted in higher solute leaching and that intermittent irrigation in smaller amounts caused the greatest leaching.

For organic solutes like herbicides, Oppong and Sagar (1992) observed a slight trend towards greater downward movement of the herbicide in soil cores when simulated rain was applied daily rather than at 4-day intervals. Ghodrati (1989), in an earlier study, observed no significant differences in the leaching patterns caused by the various water application methods (continuous or intermittent ponding or sprinkling).

In order to shed some light on these apparently contradictory findings, this study seeks to assess the effect of different irrigation frequencies on the leaching of atrazine [2-chloro-4-ethylamino-6-isopropylamino-*s*-triazine] which is among the numerous herbicides used in Ghana for maize production. This herbicide is also gradually becoming popular among some pineapple farmers because of its lower cost (Osei-Wusu, personal communication). In spite of its wide usage in Ghana, however, there is a paucity of information on atrazine and other agrochemical transport in Ghanaian agricultural fields.

It is also of scientific interest to be able to "predict" the extent of pesticide movement in soils under different irrigation frequencies, using pesticide transport models. The usefulness of pesticide movement simulation models in setting application limits has been discussed by many researchers (Wagenet and Rao, 1990; Petach *et al.*, 1991; Vinten *et al.*, 1991; Greenwood and Walker, 1990). The development of a simple pesticide transport model is, therefore, of interest to the study.

OBJECTIVES

The objectives of this study are to:

- (a) obtain basic information on the behaviour of herbicide in a Ghanaian soil,
- (b) assess the influence of different irrigation frequencies on the patterns of leaching of atrazine, and
- (c) attempt to develop a simple herbicide transport model for predicting the leaching front under the different irrigation frequencies.

CHAPTER TWO

2.0 LITERATURE REVIEW

2.1. Importance of herbicide use in the tropics

In the tropics where much of the world's crop production occurs (Brian, 1976), farmers do worry about the growth of weeds which compete with crops for nutrients and other resources. This is because advanced weed control methods such as the use of herbicides (defined here as chemicals that are used for killing or adversely affecting weed growth, Akobundu, 1987) are carried out on a limited scale. Rather, cultural weed management techniques including hand weeding, mechanical weeding, tillage, burning, flooding, mulching, and crop rotation have been widely practised. The main reason for continued use of cultural techniques has been the high cost of herbicides in many developing countries. In Ghana, for example, herbicide use is only associated with cash crop and export crop production. Herbicide use by peasant farmers who produce the bulk of food in the country is very limited. However, in recent times, the cost of hand weeding has also increased considerably. As the cost of labour has increased, manual weed control has also become expensive. Thus, farmers (current and future) may be unable to maintain large farms if appropriate weed control measures are not taken.

Chemical weed control using herbicides, therefore, may continue to be of great importance in Ghanaian agriculture if increase in crop production by means of better weed control is desired to meet the ever increasing population. Akobundu (1987) has discussed the advantages of herbicide use. These include the following:

- (a) there is less drudgery in chemical weed control than in cultural methods,
- (b) weeds can be selectively controlled without injury to crops,
- (c) pre-emergence application of herbicides protects crops from the adverse effects of early weed competition,
- (d) field labour demand is lower than in manual and mechanical weed control methods,
- (e) there is little or no soil disturbance, thus reducing the risk of soil erosion that is so common with manual and mechanical weeding, and finally,
- (f) it is simply a faster weed control method than other methods.

Although herbicides and other chemicals may seem to have the potential of reducing weed problems in Ghanaian agriculture, they can also have harmful effect on soil flora and fauna, and cause pollution of air, as well as surface and ground waters. The safe and efficient use of a herbicide, therefore, requires a knowledge and understanding of its fate in soils. Important aspects of the fate of herbicide in soil include the duration of its activity in the soil, the processes which control its persistence and the factors which affect its availability to plants and its selectivity between crops and weeds (Walker *et al.*, 1982).

2.2 The fate of herbicides in soils

Whether herbicides are applied to plant foliage or directly to the soil surface, a high proportion of the chemicals eventually moves into the soil (Brady, 1990). These chemicals may be (a) transported through runoff and/or leaching, (b) vaporised into the atmosphere, (c) adsorbed by colloidal particles (humus and clay), (d) degraded by soil microorganisms (e) taken up by plants (f)

photodecomposed and/or (g) may undergo chemical reactions. The fate of herbicides in the soil may be represented schematically as in Fig. 2.1.

In the following sections each of these processes that affect herbicides in soils will be discussed.

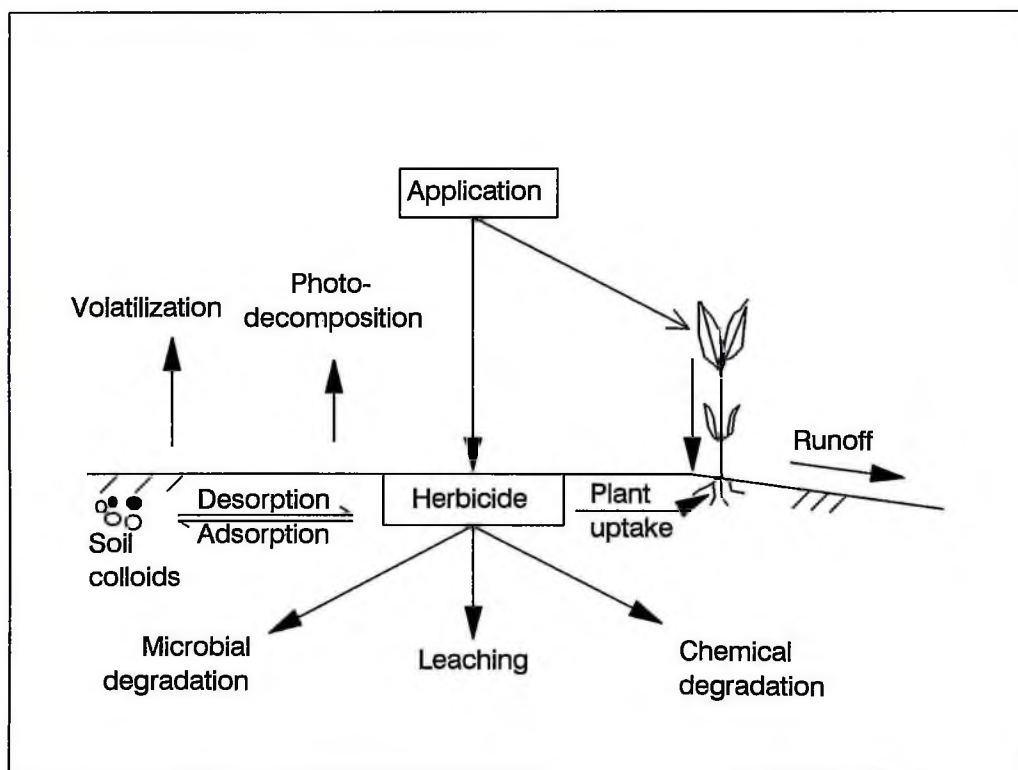

Fig. 2.1 Introduction and fate of herbicides in the environment.

(After Akobundu, 1987; Walker et al., 1982 and Frere, 1975)

2.2.1. Transport of herbicides

Herbicide transport may occur in soil solution or through attachment to eroded soil particles. Of interest to this study are losses through runoff and leaching, which are discussed in the following sections.

2.2.1.1 Runoff and Leaching

Runoff is a major cause of pollution of surface waters by herbicides and other chemicals. A number of researchers (e.g. Haith, 1980; Ahuja and Lehman, 1983; Ashraf and Borah, 1992; Frere, 1975; Sauer and Daniel, 1987) measured the losses of herbicides and other chemicals from small field plots or watersheds by surface runoff in both the water phase and on soil particles. Bailey *et al.* (1974) noted that some ways in which chemicals at the soil surface can be transferred to runoff include: mixing of rain or irrigation water with soil solution, dissolution of chemicals present in the solid form, desorption of chemicals adsorbed to the soil and adsorption of chemicals to the eroded soil or sediment. Contamination of runoff occurs when water ponds over the soil surface and runoff is initiated (Ashraf and Borah, 1992). Prior to the initiation of runoff, chemicals that are completely mixed with infiltrating water migrate downward into the soil matrix (Ingram and Woolhiser, 1980). When water ponds and runoff begins, part of the water infiltrates and the rest becomes runoff.

The factors that contribute to water runoff also have effect on pesticide loss. These may include crop residue, tillage, soil structure, rainfall intensity and infiltration rate of the soil and other soil physical properties.

Leaching refers to the downward movement of water and its dissolved substances in the soil. Although the efficacy of some soil-applied herbicide may be lost as a result of leaching especially on very light soils low in colloidal materials, soil applied-herbicides are mainly effective when they penetrate the soil some distance to be in contact with roots and young shoots of weeds (Leistra, 1980; Aldrich, 1984 and Akobundu, 1987).

Leaching of herbicides may be affected by (a) the properties of the solute (e.g. its solubility) (b) permeability of the soil (c) the soil texture and organic matter content, (d) adsorption by soil colloids, (e) initial water content, (f) crop and soil management procedures, (g) irrigation technology and amount of water applied, and (h) fertilizer application. It is worthy of note that these factors may not necessarily act independently but interact to affect herbicide leaching. Thus, the discussions of the single factors below are separated only for discussion convenience, since a discussion of all these factors simultaneously is not easy. However, where necessary, some of these factors would be discussed in relation to others.

2.2.1.2 Properties of the herbicide that influence leaching losses

The properties of herbicides important for leaching include the solubility of the chemical, its affinity for adsorption, and the formulation.

A soil-applied herbicide has to dissolve in soil water to be absorbed by weeds (Schmidt and Pestemer, 1980). Thus, if there are no other soil barriers to water movement, soils with higher field capacities would, at any time, retain more of the herbicide against leaching losses to deeper layers than those with lower field capacities.

Provided there is sufficient water available in the soil, it is the solubility of the herbicide that will determine how much of it can dissolve for weed uptake or leaching. Although Aldrich (1984) agrees that it is the portion of the herbicide in solution that is available to be leached, he holds the view that solubility is not a major factor in leaching. He explained that the amount of applied herbicide is normally extremely small compared with the amount of soil which constitutes a potential adsorbing surface. He, therefore, asserts that leachability of herbicides is affected more by adsorption, which in turn is influenced by the type of clay and organic colloids present. Herbicides that have high affinity for colloidal particles may be highly adsorbed onto the particles to minimize leaching.

Herbicide formulations may also affect leaching, generally, by altering the mobility (Gish *et al.*, 1995) but reports have not been consistent. On the one hand, Schreiber *et al.* (1987) proposed that starch encapsulation is a controlled-release formulation that could reduce leaching losses. Gish *et al.* (1991b) also observed a reduction in starch-encapsulated atrazine leachate concentrations from shallow no-tillage soil cores compared with technical-grade atrazine. On the other hand, Gish *et al.* (1995) rarely detected alachlor in any lysimeter below the root zone regardless of herbicide formulation.

2.2.1.3 Effects of soil properties on herbicide leaching.

Generally, soils with more colloidal particles (clay and organic matter) have the tendency to adsorb more herbicides, and therefore leave a smaller fraction in soil solution for plant uptake and leaching. On very sandy soils with poor adsorption all of the applied herbicide may be assumed to

be completely available in solution and potential leaching may be high. Guenzi and Beard (1967) studied four different soils and found that the movement of Lindane and DDT was greater in the soils higher in sand content. Hamaker *et al.* (1966) also reported an inverse relationship between adsorption and leaching. Leaching in most tropical soils which are dominated by kaolinitic clays with low exchange capacities may be higher than those which have other type of clays.

Leaching of herbicides may also be influenced by the permeability of the soil. Solute movement, however, may occur in both less permeable and highly permeable soils. For instance, Spalding *et al.* (1979) and Wehtje *et al.* (1984) observed high amounts of up to 23 $\mu\text{g/L}$ of atrazine in reuse pits and monitoring wells from highly permeable alluvial soils. On the other hand, Pionke *et al.* (1988) obtained a maximum of 1.1 $\mu\text{g/L}$ atrazine that leached through less permeable silt-loam/clay loam soil to a shallow groundwater (2 m) deep. Thus, although solute leaching may occur in any soil, more leaching may be associated with high permeability.

The initial water content has been shown to influence the amount of herbicide leaching. Generally, greater amounts of leaching may be expected from initially moist soils than from dry soils (Wiese and Davis, 1963). Smith (1982) explained that water competes with the herbicide for the adsorption sites on the soil colloids, thus displacing the adsorbed herbicide molecules or preventing their adsorption. On the contrary, White *et al.* (1986), observed a greater proportion of leaching of 2 herbicides (bromacil and napropamide) from initially dry cores ($\theta = 0.24$) than from prewet cores ($\theta = 0.35$). This might have been caused by swelling of the structured clay soil to reduce macropores as the water content increased.

2.2.1.4 Some soil management procedures that affect herbicide leaching.

The effects of soil management procedures such as tillage on herbicide loss have been studied extensively. Most studies focused on No-till/Conventional tillage systems. Effects of surface crop residues on interception, subsequent wash-off, and movement of herbicides through soils are concerns associated especially with no-tillage agriculture (Green *et al.*, 1995). Tillage practice can modify chemical properties by influencing the amount of organic matter critical in degrading herbicide (Stevenson, 1972; Stearman *et al.*, 1989) and by altering the physical properties that affect surface and subsurface hydrology (Burwell *et al.*, 1966; Allmaras *et al.*, 1967; Gish *et al.*, 1995).

Generally, water infiltration and agrochemical leaching can be more pronounced under no-till than conventional tillage for soils with good structural stability (Dick *et al.*, 1989; Hall *et al.*, 1989; Isensee *et al.*, 1990). Macropores, which are generally more numerous and well developed under no-tillage than conventional tillage appear to be primarily responsible for the increased rate of water infiltration and agrochemical transport (Czapar *et al.*, 1992; Edwards *et al.*, 1992 and Jones *et al.*, 1990; Starr and Glotfelty, 1990). Conventional tillage disrupts the macropores in the surface 15-20 cm whereas macropores appear to remain largely intact under no-tillage (Isensee *et al.*, 1990). Again, the effect of tillage on herbicide movement may also be dependent on the properties of the chemical. For instance, whereas Gish *et al.* (1995) rarely detected alachlor below the root zone regardless of the tillage practice, atrazine was present in the lysimeters at 2 m depth.

Crop residue on soil surface has significant impact on herbicide application. Depending on amount and type of crop residue or vegetation, 15 to 80% of applied herbicide may be intercepted (Isensee and Sadeghi, 1994; Banks and Robinson, 1982, 1984; Ghadiri *et al.*, 1984). Sigua *et al.*

(1993) observed 26 and 37% reduction in atrazine leaching when the soil was covered with 2000 and 8000 kg/ha of crop residue, respectively, compared with bare soil. Living or freshly harvested vegetation was more effective in reducing herbicide leaching than dead plant tissue such as crop residue and other residues from the previous year.

Another management technique that may affect leaching is herbicide placement. This is of particular importance in ridge tillage system. Studies suggest that when chemicals are placed on or near ridgetops, chemical movement through soils is reduced compared to placement in the furrows (Clay *et al.*, 1994). Various researchers have observed a reduction in herbicide and fertilizer movement through soil when they were applied on hill or ridges rather than on the flat or in the valley (Kemper *et al.*, 1975; Hamlett *et al.*, 1990; Saffigna *et al.*, 1976; Clay *et al.* 1994). Clay *et al.* (1994) explained that the reduced agrochemical movement from the ridge may be due to limited water movement which in turn results in limited chemical movement through the ridges.

Fertilizer application has been found to enhance the movement of some herbicides. For example, Liu *et al.* (1995) observed a decrease in atrazine adsorption and an increase in atrazine desorption as a result of application of N fertilizer done at approximately the same time as the herbicide application. They observed ammonia-induced changes in both pH and dissolved organic carbon concentration and these appeared to influence atrazine sorption characteristics. This effect, they concluded, may increase the risk of atrazine leaching through soil to contaminate shallow aquifers. Earlier, Clay *et al.* (1994) found that when atrazine and N fertilizer are applied in the same slot, atrazine movement through the soil was enhanced. This might have been due to the desorption effects explained later by Liu *et al.* (1995).

2.2.1.5 Influence of irrigation technology on herbicide leaching.

Although the physico-chemical properties of organic agrochemicals are of primary importance in deciding their movement in the soil environment, it is possible by proper management of soil water to increase the chemical's efficacy and thus reduce the amount required for pest control (Gerstl, 1991).

Irrigation technology is one of the main factors governing the fate of a herbicide in an irrigated soil. Irrigation may alter soil water conditions and thereby affect the transport of herbicides in soil (Yaron *et al.*, 1985). The amount of herbicides and water recharging the groundwater as a result of irrigation is a function of irrigation method used and the amount of water applied (Yamauchi, 1984; Yaron *et al.*, 1985; Troiano *et al.*, 1993). The movement of herbicides is also dependent on timing of first irrigation following herbicide application (Isensee *et al.*, 1990) and the quality of irrigation water (Graber *et al.*, 1995).

Increasing the amount of irrigation water may increase the amount of deep percolation which in turn may increase the amount of leaching. Ferguson *et al.* (1991), therefore, recognized in their study, the need for improvement in irrigation management to prevent excessive water application. In a related study, Opong and Sagar (1992) found that rainfall of 14 mm caused greater movement of herbicide than did either 3.5 or 7.0 mm of rainfall. It is conceivable that leaching patterns may also be affected by water application methods. Troiano *et al.* (1993) found that the distribution of atrazine in soil indicated greater downward movement in response to increases in amount of deep-percolating water. The magnitude of leaching differed between irrigation methods and increased in the order: sprinkler < basin < furrow. They ascribed these differences solely to differences in amount of percolated water produced by each treatment. However, Ghodrati (1989) observed no

significant differences in the leaching patterns caused by the various water application methods (continuous or intermittent ponding or sprinkling).

Irrigation/rainfall intensity is also a factor that may determine the extent of solute leaching in soils. Edwards *et al.* (1992) reported more atrazine leaching by high- compared to low-intensity rains. Boddy and Baker (1990) observed that the flow weighted average concentrations of atrazine in drainage, for a 50 mm/hr rainfall, was over 3 times as high as for a 10 mm/hr rainfall. They suggested that the increased concentrations resulted from a greater and more rapid movement of the chemical through larger soil pores during the more intense rainfall, which may have reduced contact time with the soil and, therefore, decreased adsorption of the herbicide. Sigua *et al.* (1992), however, observed leaching of considerable amounts of solute through surface soil by long duration, low intensity simulated rains. An average of 92% (Bromide, Br) and 52% (atrazine) of the total amounts applied were leached through soil cores by 2 pore volumes of simulated rain applied at 12 mm/hr compared with 61% for Br and 33% for atrazine at 3 mm/hr rate.

The sooner a rain occurs after application, the more likely is the herbicide leaching (Starr and Glotfelty, 1990; Shipitalo *et al.*, 1990; Isensee and Sadeghi, 1994). It has been noted further that the amount of initial rains following agrochemical application can also influence leaching. A small initial rain will significantly reduce the amount of pesticides leached by subsequent larger rains presumably by increasing soil-pesticide interactions which reduce amount of pesticide available for leaching (Shipitalo *et al.*, 1990).

To alleviate chronic water shortages in many parts of the world and to minimize pollution of surface water from sewage effluent, the treated sewage effluents have been used for irrigation (Graber *et al.*, 1995). This practice may lead to increased concentration of heavy metals and other

contaminants below the root zone. For example an accumulation of many organic compounds was found well below the root zone in an effluent-irrigated citrus grove by Muszkat *et al.* (1993) but not in groves irrigated with higher quality water. Recently, Graber *et al.* (1995) also found that atrazine in effluent-treated columns (4 m high) was more strongly leached than that in high-quality water-irrigated cores.

One aspect of irrigation management techniques is the high-frequency irrigation (i.e. frequent application of irrigation water). Opong and Sagar (1992) observed a slight trend towards greater downward movement of the herbicide in soil cores when simulated rain was given daily rather than at 4-day intervals. Varying the frequency of irrigation water application may lead to differences in the amounts of deep percolating water and this might in turn cause different amounts of leaching. Some researchers (Rawlins, 1973; Rawlins and Raats, 1975) have reviewed the prospects and principles of high-frequency irrigation and others (Phene and Beale, 1976) have found it to be beneficial in terms of crop water use. But the general effects of varying irrigation frequency on herbicide movement has not received sufficient research attention.

2.2.2 Pesticide-soil interaction

2.2.2.1 Adsorption

Adsorption is a process in which interaction occurs between the adsorbent surface and the molecules or ions of the adsorbate. Generally, this interaction causes the adsorbate to be attracted to the surface, reducing its concentration in solution (Walker *et al.*, 1982; Akobundu, 1987). The adsorbent are mainly the colloidal particles and these have negatively charged sites to which herbicides can be adsorbed. A number of forces may be involved in adsorption. Calvet (1980)

grouped them into 2 categories:

- i. High energy bonds (> 80 kJ/mole) which include ionic bonds and ligand exchange, and
- ii. Low energy bonds (< 80 kJ/mole) e.g. ion-dipole and dipole-dipole interactions, hydrogen bonds and Van der Waals bonds.

The detailed discussion of each bond is beyond the scope of this work.

For a particular chemical and its association with soil, multiple mechanisms of sorption may be involved (Scow, 1993). Atrazine, being a weak base, may become electrically charged depending on the acidity of the medium. Thus, both the high energy bonds e.g. ionic bonds (Calvet, 1980), ligand exchange (Hamaker and Thompson, 1972) as well as low energy bonds e.g. hydrogen bonds (Calvet and Terce, 1975) have been suggested as the dominant adsorption mechanisms.

Adsorption of herbicides in soils depends on three factors: (1) the molecular properties of the adsorbate, (2) soil constitution or nature and properties of the soil colloids, and (3) the features of the soil environment (Yaron, 1989; Calvet, 1980). These factors are briefly discussed in the ensuing paragraphs.

Molecular properties

The important molecular properties of the adsorbate in the adsorption of herbicide may include the electronic structure, molecular volume and water solubility (Yaron, 1989). The molecular structure determines the ionization potential of a compound which is in turn controlled by functional groups such as COOH, NH, CO, etc. The ability of a molecule to ionize, which depends on the electron distribution in the molecule and on its electron mobility, is the primary reason why many pesticide-soil interactions are pH-dependent. The solubility of a herbicide is

sometimes considered as an approximate indicator of its adsorption (Khan, 1980). For nonionic herbicides (e.g. diuron) aqueous solubility is the most important molecular parameter correlated to adsorption. In general, highly soluble non-ionic pesticides have low adsorption coefficients for soils while the opposite holds true for chemicals of low solubility (Hassal, 1990; Yaron, 1989; Rao and Jessup, 1983; Hilton and Yuen, 1963; Grover, 1975). Some researchers, however, found no correlation between adsorption and solubility (Briggs, 1969; Hance, 1965).

Soil constituents

The soil constituents that control adsorption are the soil organic matter, clay minerals and amorphous minerals (Yaron, 1989; Yaron *et al.*, 1985; Khan, 1980)

Clay minerals have a negative charge that is balanced by exchangeable cations and thus are important in adsorption of cationic and protonated herbicides by acting as strong proton donors (Bailey *et al.*, 1968). A number of researchers (Harper, 1988, Ladlie *et al.*, 1976; Savage, 1976) have, therefore, observed a highly positive correlation between adsorption and clay content. The extent of adsorption may, however, be dependent on the type of clay mineral since they have different exchange capacities. Soil organic matter is, generally, considered the main adsorbent component of soils for many herbicides, especially non-ionic herbicides (Yaron *et al.*, 1985). Brouwer *et al.* (1990) observed a linear relationship between the logarithm (base 10) of the adsorption coefficient of atrazine and the logarithm of organic matter content. Humic acids and humins are the important constituents that have been reported to be responsible for adsorption of organic compounds in soils (Burns *et al.*, 1973).

Other soil constituents that may be involved in adsorption of herbicides are amorphous materials (oxides and hydroxides of Fe and Al, and allophane). Hilton and Yuen (1963) reported that amorphous materials in Hawaiian soils greatly influenced the adsorption of pre-emergence herbicides.

Features of the soil environment

The distribution of herbicides among the soil phases is also influenced by the soil environment. Features of the soil environment that may affect adsorption of herbicides are temperature, pH, ionic composition, and soil:solution ratio.

In general, adsorption processes are exothermic (Madhun *et al.*, 1986; Yaron, 1989; Dunigan and McIntosh, 1971) and changes in soil temperature could have a direct impact on the phase distribution of pesticides. Changes in temperature can either increase, decrease, or leave unchanged the extent of adsorption in a given system (Gerstl and Mingelgrin, 1979; Calvet, 1980). For example, Yaron *et al.* (1985) reported that increasing temperature results in decreased adsorption because of an increase in the solubility of most compounds at higher temperatures. For diuron, Madhun *et al.* (1986) and Liu *et al.* (1970) found this relationship to hold. However, Dunigan and McIntosh (1971) and McGlamery and Slife (1966) found that adsorption of atrazine increased with increasing temperature. Yet, Calvet (1980) observed no effect of temperature increase on adsorption of atrazine and other herbicides on peat. The high colloidal content of peat is likely to offset any effect due to temperature increase.

The pH of a system is also an important factor as it governs the ionization of most organic molecules. Soil pH influences the protonation of atrazine (a weakly basic molecule) and the charge

on the adsorbent surface (Koskinen and Harper, 1990; Calvet, 1980). Atrazine is, therefore, adsorbed to a greater extent in low pH than in high pH soils (McGlamery and Slife, 1966; Goetz *et al.*, 1988) and has greater desorption from high pH than from low pH soils (Clay and Koskinen, 1990). Nonetheless, at very low pH values (2-5) the clay edges may retain a net positive charge, thus favouring repulsion of some herbicides especially the protonated and cationic ones (Walker *et al.*, 1982). For phenylureas (e.g. Diuron), Hance, (1969a) and Yuen and Hilton (1962) observed no significant effect of the pH of the system on adsorption while Frissel and Bolt (1962) and Harris and Warren (1964) observed that adsorption of these herbicides by clay minerals was slightly greater under acid conditions than under basic or neutral conditions. These latter authors did not state the significance of the difference observed.

Soil water ratio

Adsorption generally has been found to increase as the water content decreases (Walker *et al.*, 1982; Savage and Wauchope, 1974, Farmer and Aochi, 1974; Hance, 1977). The soil moisture content affects the adsorption process by modifying the accessibility of the adsorption sites and the surface properties of the adsorbent. For non-ionic herbicides (e.g. diuron) competition exists with water for the adsorption sites and negative relationships between herbicide adsorption and soil moisture content have often been reported (Yaron, 1989). For example, Hance (1965) observed a competition between water and diuron for adsorption sites, and also diuron was a more effective competitor at soil organic matter surfaces than at soil mineral matter surfaces.

Khan (1980) reported that moisture content influences adsorption of s-triazines (e.g. atrazine) in soil. He, however, did not describe the type of relationship that may be observed as water content changes.

Ionic composition

The presence of salts in the soil solution may cause a decrease in the adsorption of cationic species owing to competition for exchange sites (Yaron *et al.*, 1985). Neutral molecules are generally less affected by salts but may show increased adsorption with increasing salt concentration (Yaron *et al.*, 1985). Some nitrogen fertilizers are capable of increasing soil pH to 9 or greater (Kissel *et al.*, 1988; Norman *et al.*, 1987). Thus, when such fertilizers are applied together with some pre-emergence herbicides they may cause desorption and decrease adsorption of the herbicides. For instance, Liu *et al.* (1995) observed a 50% decrease in atrazine sorption whilst atrazine desorption doubled when aqueous ammonia fertilizer and atrazine were applied simultaneously.

2.2.3 Herbicide degradation in soils

2.2.3.1 Microbial degradation

Microbial degradation of herbicides in soil is one of the most important of all environmental processes that can result in the eventual mineralization of the herbicide. The microbes use these chemicals as their energy source to effect mineralization of the herbicide. Microbial action on herbicides is largely limited to that fraction of a dose of herbicide that is present in soil water (Hassal, 1990). The fraction in soil water may, thus, be limited by adsorption to soil colloids. It is beyond the scope of this work to discuss the details of herbicide degradation. Rather, only factors that may affect the process of degradation will be briefly discussed. Those of interest to this study are soil type, pH, temperature and moisture content, and depth within the soil profile.

Soil type

Soils high in organic matter content tend to have greater microbial activity (Yaron *et al.*, 1985; Hurlle and Walker, 1980). However, adsorption of most herbicides increases with an increase in soil organic matter, and since adsorption reduces the amount of herbicides available in the soil solution, it might provide protection from degradation (Hurlle and Walker, 1980; Yaron *et al.*, 1985; Yaron, 1989). Hamaker (1972) suggested that an increase in organic matter might increase rates of degradation in mineral soils up to a limiting value, above which the rates of loss would be retarded. Some researchers (Walker and Thompson, 1977) have found that linuron degraded more rapidly in soils with higher organic matter contents. Others (Briska *et al.*, 1973; Smith and Meggit, 1970), however, observed a decreased herbicide degradation in soils higher in organic matter content.

Clay minerals have differential capacity to sorb herbicides. It is conceivable that soils with montmorillonitic clays will protect herbicides from biodegradation than those with kaolinitic clays, as the former clay type has a higher surface activity.

Soil reaction

Microbial degradation may also be affected by the pH of the medium but the effect does not seem to be clear cut as published results appear to be conflicting. For instance, atrazine degradation was found to increase as soil pH decreased (Best and Weber, 1979), decrease as soil pH decreased (Hance, 1979; Ladlie *et al.*, 1976) or was nearly unaffected (Dao *et al.*, 1979; Hance, 1979).

Temperature and moisture content

Temperature and soil moisture content have not been found to control microbial degradation specifically but rather metabolic activity in general (Yaron *et al.*, 1985). In accordance with the laws of reaction kinetics, it has been found that the rate of herbicide degradation increases with increasing temperature (Hamaker 1972; Smith and Walker, 1989).

Moisture content is also important because it controls oxygen level in soils by occupying the pore space. Guenzi and Beard (1976) found that degradation decreased as the water content decreased, and ceased when the soil was air-dried. This might be attributed to the effect of moisture on herbicide adsorption as already explained. Hence, high adsorption as a result of a decrease in soil moisture content may have protected the herbicide from being degraded.

Depth within the soil profile

Harris *et al.* (1969) and Adams and Thurman (1991) observed decreased atrazine degradation with increasing soil depth. These trends may be the result of higher organic matter and hence higher microbial population in the surface soils (Focht and Joseph, 1973). Thus herbicide that is leached to the subsoils may be sufficiently persistent to represent a long-term contamination threat to groundwater (Johnson and Fuhrmann, 1993).

2.2.3.2 Chemical degradation

Chemical conversion of herbicides in soils is a phenomenon that may play an important role in the dissipation of many herbicides in soils. Although it may sometimes be difficult to distinguish between purely chemically and microbially governed reactions especially since in many cases there

are striking similarities between mechanisms and/or degradation products (Yaron *et al.*, 1985), chemical degradation of herbicides in soil has been recognized. For example, Dao *et al.* (1979) observed that for up to 8 months degradation of atrazine was predominantly a non-biological process even in non-sterilized soils. A range of chemical reactions involving soil-applied herbicides may lead to hydrolysis, oxidation, reduction or formation of more complex molecules (Akobundu, 1987; Khan, 1980).

Chemical degradation of herbicides that occurs in soil may be catalyzed in several different ways. Catalysis by clay surfaces, metal oxides, metal ions, and organic matter have been reported (Khan, 1980). For atrazine the mechanism of soil catalysis appears to be directly related to the extent of adsorption (Armstrong and Chesters, 1968). Nearpass (1972) reported that chemical hydrolysis of propazine was catalyzed by adsorption on soil organic matter. Montmorillonite was shown to be the most effective clay mineral in hydrolysis of herbicides in soil (Brown and White, 1969; Russell *et al.*, 1968).

The pH of the soil also controls the rate of atrazine hydrolysis (Armstrong *et al.*, 1967). In general, the rate is greater in soils containing high organic matter and low pH (Armstrong *et al.*, 1967). Beyer *et al.* (1987) concluded that chemical hydrolysis was the predominant cause of herbicide degradation in acid soils.

Breakdown was also found to be rapid in warm and moist soils (Beyer *et al.*, 1987; Armstrong and Chesters, 1968). Hance (1969b), however, observed that hydrolysis of atrazine and other herbicides increased as the soil:solution ratio increased.

2.2.3.3 Photodecomposition

Photodecomposition may have a pronounced effect on success of soil applied herbicides especially the pre-emergence herbicides (Akobundu, 1987; Aldrich, 1984). It is the ultraviolet wavelength of sunlight that is responsible for most photodecomposition of herbicides in the field. Light within this wavelength range energizes quite a variety of common reactions including oxidation, reduction, elimination, hydrolysis, substitution and isomerization (Aldrich, 1984; Crosby, 1976). It is known that many herbicides may have their activity reduced if exposed to light for any length of time on the soil surface.

Photodecomposition is insignificant below the top few centimetres of soil (Jury and Fluhler, 1992). Thus, many pre-emergence herbicides may be protected from photodecomposition by incorporating them into the soil (Akobundu, 1987; Aldrich, 1984). In addition, adsorption which, as we have already seen, may be substantial for many herbicides, may also protect the herbicide against photodegradation. Some phenylureas (Harris and Warren, 1964) and the *s*-triazines (Jordan *et al.*, 1963) are among the herbicides found to be sensitive to photodegradation.

2.2.4 Plant uptake

Some proportion of herbicide applied is removed by plants through the foliage and roots. Removal from soil through the roots occurs via uptake of water. As mentioned in Sub-sub-section 2.2.1.2 on page 9, only herbicides dissolved in available water may be taken up by plants. Atrazine is applied directly to the soil as pre-emergence herbicide, and is taken up through the roots. The site of action of the herbicide is the chloroplast where the chemical may act as an inhibitor of photosynthesis (Akobundu, 1987). Crops or plants that are tolerant or resistant to a particular

herbicide are able to degrade it to less toxic molecules. Others are, however, killed. The detailed description of the mode of action of herbicides in plants is beyond the scope of this work.

2.2.5 Volatilization of herbicides

Volatilization is defined as the loss of chemicals from surfaces in the vapour phase, e.g. vapourization, followed by movement into the atmosphere (Yaron *et al.*, 1985). It is an important pathway for pesticide loss from treated agricultural lands (Gish *et al.*, 1995; Weinhold and Gish, 1994; Yaron *et al.*, 1985). It may be influenced by the vapour pressure of the herbicide, soil organic matter and amount of clay, soil moisture, adsorption properties of the herbicide, herbicide formulation, soil temperature, mode of application (i.e. surface application vs. incorporation), and rate of air flow resulting in drift of droplets or vapour of volatile herbicides (Glotfelty and Schomburg, 1989; Akobundu, 1987; Aldrich, 1984; Khan, 1980).

For significant losses from soil surface by volatilization to occur, herbicide vapour pressures in excess of 10^{-4} mmHg are necessary (Akobundu, 1987; Smith, 1982). However, even non-volatile herbicides such as the substituted ureas, could be lost by volatilization (Aldrich, 1984; Walker *et al.*, 1982) but movement of the herbicide into the soil and adsorption may reduce such losses (Walker *et al.*, 1982).

Incorporation of herbicide into soil can minimize vapour loss. Walker *et al.* (1982) observed that 90% of trifluralin, applied to the soil surface volatilized in 2-3 days whereas losses were only 22% in 120 days when it was incorporated to 2.5 cm.

Herbicide formulation may also have significant effect on herbicide volatilization. A herbicide applied as a liquid formulation has a greater chance of volatilizing than same herbicide

as granular formulation (Akobundu, 1987; Walker *et al.*, 1982). Weinhold and Gish (1994) found that starch encapsulation appeared to be a viable formulation modification for reducing volatilization losses of herbicides, especially from no-tillage fields. They observed that starch encapsulation did not affect volatilization of alachlor but substantially reduced that of atrazine. These differences were attributed to the higher solubility of alachlor (240 mg/L) in water than that of atrazine (32 mg/L) resulting in quicker release of alachlor from the starch matrix and enhanced adsorption by soil.

Herbicide volatilization is greater from moist than from dry soil surfaces (Aldrich, 1984; Smith, 1982; Walker *et al.*, 1982; Khan, 1980; Spencer *et al.*, 1973). Taylor (1978) reported that volatilization rates from plant and moist soil surfaces can be very large, with losses approaching 90% of the original amount applied within 3 days for more volatile pesticides. On a wet soil there is competition between water and herbicide for adsorption sites, so that as the water content increases there is a reduction in the amount of herbicide adsorbed making it susceptible to volatilization (Akobundu, 1987; Smith, 1982; Walker *et al.*, 1982).

Pesticide volatilization is less from cool and dry soil than from warm and moist soil surfaces (Walker *et al.*, 1982; Khan, 1980; Spencer *et al.*, 1973). Temperature affects the volatilization from soils by a direct influence on the vapour pressure of the chemical (Khan, 1980) and the response usually follows the relationship (Hance, 1980):

$$\log_{10} p = A - B/T$$

2.1

where p is the vapour pressure, A and B are constants, and T is the temperature ($^{\circ}\text{C}$).

Increased soil organic matter content generally decreases volatilization (Spencer and Cliath, 1974). Other researchers have also obtained an inverse relationship between the rate of pesticide volatilization and soil organic matter content (Guenzi and Beard, 1970; Fang *et al.*, 1961). Ashton and Sheets (1959) attributed the greater effectiveness of volatile herbicides in soils that are high in organic matter to the reduction in volatility caused by the adsorption of the herbicides on organic matter. Kearney *et al.*, (1964) observed that vapour losses of triazines appeared to be inversely related to the amount of clay and organic matter.

Volatilization of herbicides may also be influenced by the rate of air flow (Akobundu, 1987; Khan, 1980). Apart from the direct effect of drift of droplets and vapour during herbicide application (Akobundu, 1987; Walker *et al.*, 1982) more volatilization is likely to occur with increased air flow rate (Khan, 1980).

The effects of tillage on volatilization has also been reported recently in the literature. Weinhold and Gish (1994) found that although volatilization losses were initially greater under no-tillage, cumulative volatilization losses under no-tillage during a 35-day period were about one-half those observed under conventional tillage. The reduction in cumulative losses under no-tillage might have been due to the effect of organic matter which is usually higher in no-tillage soils than in conventionally tilled soils.

2.3. Modelling the movement of herbicides in soil

The review of literature has so far discussed the general components of the fate of an applied herbicide, as depicted in Fig. 2.1. As noted in Chapter 1, however, this particular study is biased towards herbicide transport in soils and attempts to formulate a simple model for describing such

mechanisms of herbicide transport. The rest of this chapter is, therefore, geared towards a review of some solute transport models. The direct application of these models to describe the particular herbicides used in this study will be discussed in later chapters.

2.3.1 The Burns' Leaching Equation

Burns (1974) proposed a simple model for predicting the redistribution of salts applied to fallow soils after excess rainfall or evaporation. Burns' model assumes that the soil profile is divided into a number of discrete segments, each of which is characterised by its own field capacity, F , the initial values of actual water P_i and solute present C_i .

Let P be the amount of irrigation applied to the soil and ignore evaporation losses. If $P > 0$, then salt leaching occurs. If $P = 0$, then no movement of water or salt is assumed to occur. Burns' model, generally, ignores solute distribution which arises from diffusion processes.

According to the Burns' model (which also ignores runoff), water (P) applied to the top segment increases the water content of that segment to $P_i + P$, while the effects of convection and dispersion cause mixing of the salts present. If the applied water contains dissolved solutes (C_w) and the assumption of complete mixing holds true, then the new salt content of the segment becomes: $C_w + C_i$.

Downward percolation of water is only allowed if the new water content of the first segment $P_i + P$ exceeds the field capacity of the segment, F . In the case of percolation, the amount of water that percolates to the next layer W_p is:

$$W_p = P_i + P - F$$

so that the final water content of the top segment becomes F .

It is noted that W_p represents the fraction of water, Z_p , that was temporarily held in the first segment, such that:

$$Z_p = \frac{W_p}{P_i + P} \quad 2.3$$

Since complete mixing of solutes are assumed to have occurred prior to percolation, then Z_p also represents the fraction of solute moved downwards through leaching. It follows that the actual quantity of solute leached is given by:

$$C_L = (C_i + C_w) \times Z_p \quad 2.4$$

and the salt remaining in the top segment becomes

$$C_r = C_i + C_w - C_L \quad 2.5$$

The water storage and solute content of the next layer become $P_i + W_p$ and $C_i + C$, respectively, and a comparison with F is made to determine whether percolation from second segment downwards occurs or not. The calculations are continued for each segment in turn until the required depth is reached.

The simple Burns' model is one of the few equations to be applied to describe anion mainly NO_3^- leaching in many practical problems (Burns, 1980; Rose *et al.*, 1982). According to Scotter *et al.* (1993), there are probably three reasons for the wide use of Burns' model, namely: (i) the model requires only estimates of field capacity, F and the amount of water application, I ; (ii) the

model is simple to use, (iii) the model can be applied over a wide range of soils except for swelling and cracking clays. For it to be applicable to reactive chemicals (e.g. herbicides), Burns' model may also need to be extended to account for adsorption of herbicides on soil colloids.

2.3.2 The Convective-dispersion equation

A more mechanistic approach to the description of solute flow through soils is to consider the convective-dispersion models. According to the approach, the movement of a chemical through the soil involves both diffusion and mass flow processes (Yaron *et al.*, 1985; Khan, 1980; Letey and Farmer, 1974). Details of the description of these processes are given below.

2.3.2.1 Diffusion

Diffusion is the process by which matter is transported as a result of random molecular motion caused by the molecule's thermal energy. The relative importance of diffusion in soil water and air depends in part on the solubility of and vapour pressure of a herbicide. There is a net movement from positions of high concentration to positions of lower concentration (Khan, 1980; Letey and Farmer, 1974).

According to Fick's (first) law of diffusion, the quantity of matter that diffuses across a unit cross-sectional area per unit time, q (m s^{-1}) is given by:

$$q = -D \frac{\partial C}{\partial x} \quad 2.6$$

where D is the diffusion coefficient ($\text{m}^2 \text{s}^{-1}$), C is the concentration (kg m^{-3}), and x , the space coordinate measured normal to the section (m). Under transient conditions where solute

concentration within a medium changes with time, the rate of change in solute concentration may be described by Fick's second law as:

$$\frac{\partial C}{\partial t} = D \frac{\partial^2 C}{\partial x^2} \quad 2.7$$

where t is time.

For the purpose of this study which focuses mainly on herbicide transport in soils, the effect of some soil and environmental factors on the diffusion of herbicides can be important. These are briefly discussed below.

Adsorption

Herbicide diffusion is affected by adsorption by soil colloids. An inverse relationship has been observed between adsorption by soil colloids and diffusion of herbicides (Walker and Crawford, 1970; Lindstrom *et al.*, 1968). Soil colloids have large surface area which tend to adsorb herbicide molecules and thus may lower their diffusion.

Soil water content

The diffusion of herbicides through soil at various soil water contents has been investigated. Lavy (1970) observed that the average diffusion coefficients of three s-triazines measured in six soils were 0.26×10^{-8} and 1.83×10^{-8} $\text{cm}^2 \text{sec}^{-1}$ at one-half field capacity and field capacity, respectively. Scott and Phillips (1972) also observed an increase in diffusion with increasing soil water content.

Temperature

The effect of increasing temperature is to increase in diffusion (Khan, 1980). Lavy (1970) reported a decrease in the diffusion coefficients of atrazine, propazine and simazine as the temperature in several soils was decreased from 25 to 5 °C.

Bulk density

Increase in soil bulk density results in a decrease in diffusion. The principal effect of bulk density is that of a reduced pore space which may limit the vapour and liquid phase movement.

2.3.2.2 Mass flow

The second but perhaps the most prominent mechanism of solute transport is by mass flow. Mass flow occurs as a result of external forces acting on the carrier for the herbicide in question. The herbicide may be dissolved or suspended in water, present in the vapour phase, or adsorbed on solid mineral or organic components of the soil (Letey and Farmer, 1974). Mass flow of herbicides may, therefore, result from mass flow of water and/or soil particles with which the soil is associated. The convective transport (mass flow) of a solute by water can be described as:

$$q_c = q_w C \quad 2.8$$

where q_c is flux of solute with concentration C , and q_w is Darcian flux (m s^{-1}), given by:

$$q_w = -K(\theta) \frac{dH}{dz} \quad 2.9$$

where K is hydraulic conductivity (m s^{-1}), H is soil hydraulic potential (m), and z is depth (m). Mass

Temperature

The effect of increasing temperature is to increase in diffusion (Khan, 1980). Lavy (1970) reported a decrease in the diffusion coefficients of atrazine, propazine and simazine as the temperature in several soils was decreased from 25 to 5 °C.

Bulk density

Increase in soil bulk density results in a decrease in diffusion. The principal effect of bulk density is that of a reduced pore space which may limit the vapour and liquid phase movement.

2.3.2.2 Mass flow

The second but perhaps the most prominent mechanism of solute transport is by mass flow. Mass flow occurs as a result of external forces acting on the carrier for the herbicide in question. The herbicide may be dissolved or suspended in water, present in the vapour phase, or adsorbed on solid mineral or organic components of the soil (Letey and Farmer, 1974). Mass flow of herbicides may, therefore, result from mass flow of water and/or soil particles with which the soil is associated. The convective transport (mass flow) of a solute by water can be described as:

$$q_c = q_w C \quad 2.8$$

where q_c is flux of solute with concentration C , and q_w is Darcian flux (m s^{-1}), given by:

$$q_w = -K(\theta) \frac{dH}{dz} \quad 2.9$$

where K is hydraulic conductivity (m s^{-1}), H is soil hydraulic potential (m), and z is depth (m). Mass

flow due to air movement in soil is considered negligible. Leaching of herbicides is usually dominated by mass flow, although diffusion occurs simultaneously (Khan, 1980).

Mass flow of solutes may be affected by the liquid flux or water flow rate, water content, bulk density and pore characteristics as determined by the soil aggregate sizes. Davidson and Chang (1972) measured the effect of some of the above-mentioned factors and reported that a tenfold decrease in water velocity caused a significant decrease in picloram mobility. High liquid fluxes cause the peak of herbicide distribution to move faster than expected from equilibrium adsorption (Yaron *et al.*, 1985; Davidson and McDougal, 1973).

When diffusion and convection occur simultaneously under steady water flow conditions, non-reactive solute transport may be described by the convective-dispersive equation given by

$$\frac{\partial C}{\partial t} = D \frac{\partial^2 C}{\partial x^2} - v \frac{\partial C}{\partial x} \quad 2.10$$

where D is dispersion coefficient, and v is average pore water velocity.

For reactive solutes like herbicides and other organic chemicals under transient flow conditions, Rao and Jessup (1983) described the flow by the following equation

$$\frac{\partial C}{\partial t} = D \frac{\partial^2 C}{\partial x^2} - v \frac{\partial C}{\partial x} - \frac{\rho}{\theta} \frac{\partial S}{\partial t} \pm Q \quad 2.11$$

where ρ is soil bulk density (kg m^{-3}), S is adsorbed solute concentration (kg/kg), θ is volumetric water content ($\text{m}^3 \text{m}^{-3}$) and Q is a sink or source term.

Although equation 2.11 has also been applied widely in modelling solute transport in soils (Nielsen and Biggar, 1962; Jardine *et al.*, 1989), it requires details on the knowledge of soil

hydraulic properties. The complete description of these properties adds another level of complexity to the use of equation 2.11. Further, solution of equation 2.11 usually requires numerical techniques using high speed computer.

In this study, therefore, an attempt is made to predict water and herbicide transport in soil using simpler equations which are still related to the process of mass flow.

CHAPTER 3**3.0 MATERIALS AND METHODOLOGY****3.1 Experimental Site****3.1.1 Location and Climate**

The study was conducted between November 1 and December 20, 1995 at the University of Ghana Farm, Legon (Lat 5° 39'N and Long 0° 11'W). The site has an elevation of 30 m and receives an annual rainfall of 635-1143 mm. Mean monthly rainfall (mm) and the temperature distributions are shown in Fig. 3.1. There was no rainfall during the experimental period.

3.1.2 Soils

The soils (Adenta series) can be classified as Kaolinitic Isohyperthermic Paleustalf (Soil Survey Staff, 1992). Morphologically, these soils are deep to very deep, red and brown, moderately heavy to medium-textured soils which are devoid of concretions and gravel at least to 0.6 m from the surface and developed from weathered products of tertiary sands. The soils, among others, are good for both mechanized and hand cultivation in the coastal savanna areas of Ghana (Acquaye and Laryea, 1982; Ahenkorah *et al.*, 1994). The top 0.8 m of the soil has field capacity of 0.27 m³/m³ and permanent wilting point of 0.13 m³/m³. There had been no application of any herbicides in the years prior to the commencement of the study.

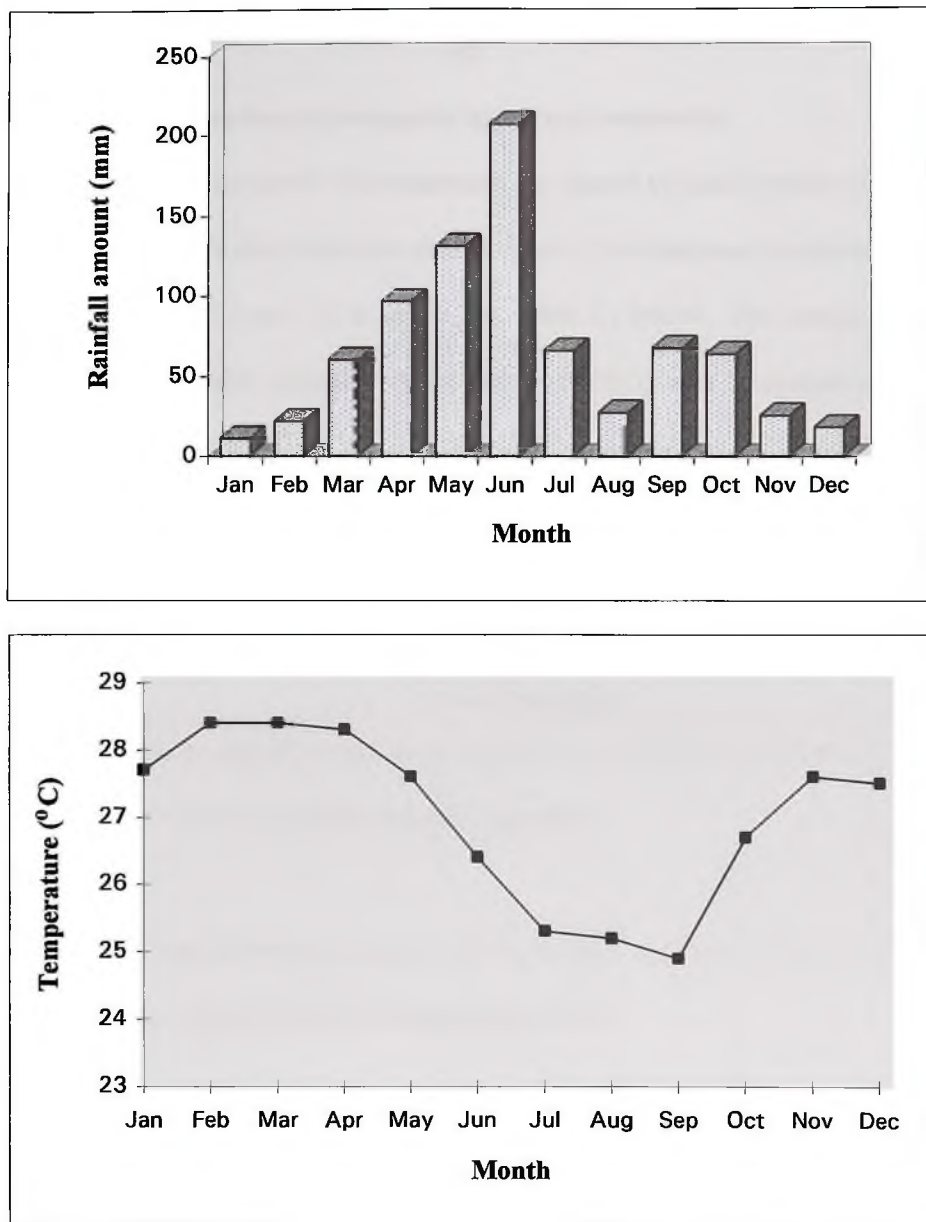

Fig. 3.1 Mean monthly rainfall and temperature for Accra
Source: Ghana Meteorological Annual Report (1990); (30 years average)

3.2 Site preparation, experimental layout and treatments.

The vegetation at the site for the experiment was cleared by hand weeding with a cutlass. Plots of size 1 m x 1 m were then established on the field site. The treatments comprised 3 different irrigation practices: T1, T2 and T3, as detailed in Table 3.1 below. The arrangement of the treatments in a Randomized Complete Block Design (RCBD) with 3 replications is shown schematically in Fig. 3.2.

Table 3.1 Description of irrigation treatments studied

Symbol	Short Description
T1	150 mm applied in three equal amounts (i.e. 50 mm each) on days 1, 9 and 17 from commencement of experiment,
T2	150 mm in five equal amounts of 30 mm each on days 1, 5, 9, 13 and 17 from commencement of the experiment, and
T3	150 mm in nine equal amounts of 16.6 mm each on days 1, 3, 5, 7, 9, 11, 13, 15 and 17 from commencement of experiment.

In this study T1, T2 and T3 were referred to as "low", "medium" and "high frequency irrigation", respectively. Adjacent plots were at least 2 m from each other, and thus were hydrologically independent.

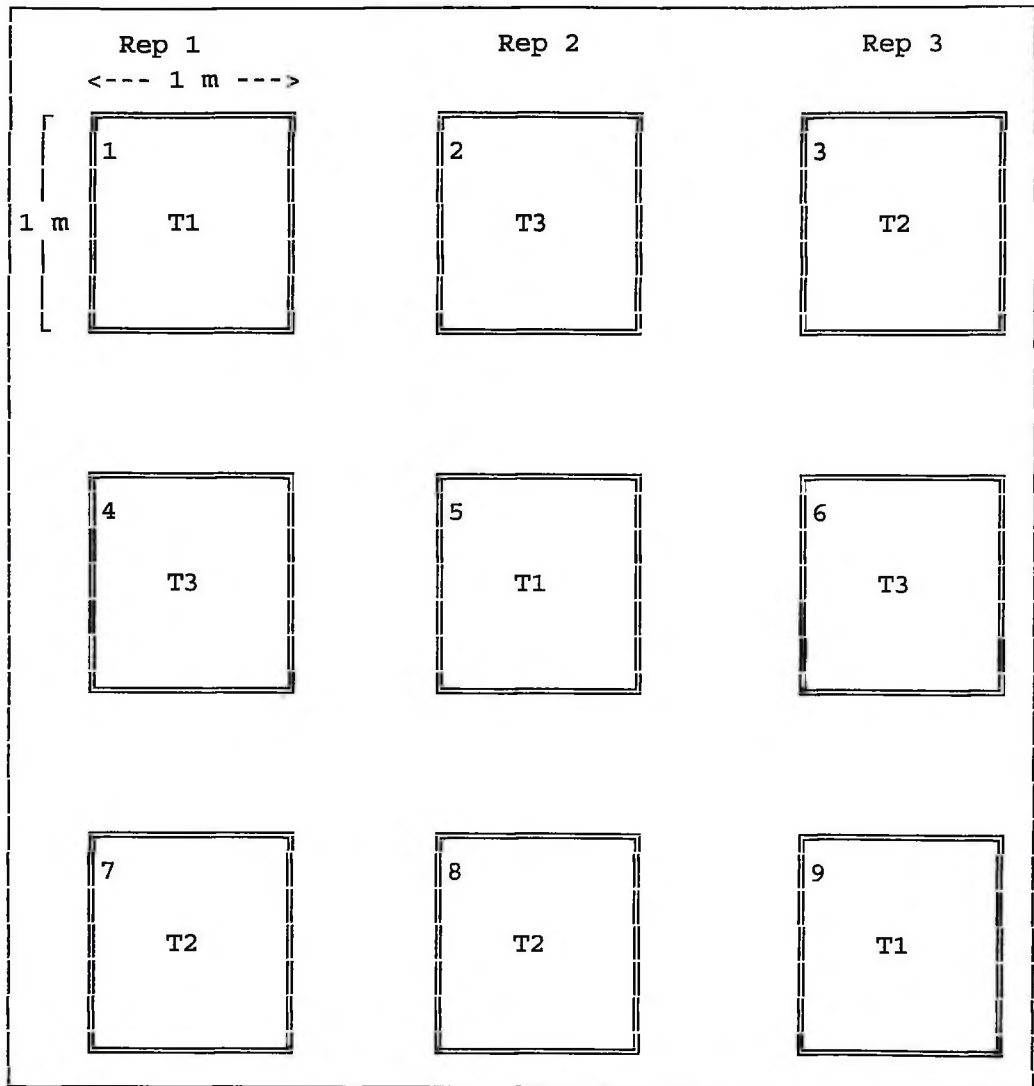

Fig. 3.2 A schematic presentation of the layout of plots on the field.

3.3 Application of atrazine

Prior to the commencement of the irrigation treatment, each plot received an application of Atrazine [2-chloro-4-ethylamino-6-isopropylamino-*s*-triazine], formulated as Atrisien 500 SC at the recommended rate for maize i.e. 2.5 kg/ha (Ministry of Agriculture, 1991). Considering the

concentration of active ingredient (a.i.) of 500 g/L, the quantity applied corresponds to 0.5 mL of Atrasien 500 SC per plot.

3.4 Irrigation application

A total amount of 150 mm of water was applied within 30 days for each treatment. This amount of water applied was selected to fall within the range of the seasonal water use of most annual crops reported by FAO (Dorenboos and Kassam, 1979).

At each time of application, irrigation water was applied using a graduated watering can in a manner which prevented ponding. The exact amount of water applied at each irrigation was noted. Plots were covered with plastic sheet immediately after water application to minimise evaporation and prevent rainwater from infiltrating the treatment plots.

3.5 Soil sampling, extraction and atrazine residue analysis

Soils of the treatment plots were sampled at 2, 7, 15 and 22 days after the commencement of the irrigation by augering. The soils were sampled at 0.1 m intervals to a depth of 0.8 m. Holes created during sampling were backfilled with untreated soil and identified by fixing a plastic straw at each spot to avoid the possibility of resampling the filled soil. Whenever sampling coincided with irrigation, the sampling was done before irrigation. Soil samples were air-dried, ground, passed through a 2-mm sieve and packed in plastic bags for herbicide analysis.

The Delley's method (Knusli *et al.*, 1969) was used to determine atrazine residues in the soil. It involved extraction and hydrolysis of atrazine to hydroxyatrazine. The cation of the hydrolysis

product was scanned at a maximum absorbance of 240 m μ . The detailed procedure is presented as follows:

A 20-g sub-sample of the soil was shaken with 20 ml of chloroform for 30 minutes. The slurry was filtered with No. 32 Whatman filter paper and the volume of the filtrate was recorded. This volume was then evaporated to dryness on a water bath in a 250-ml beaker, using a gentle stream of air. The residue was taken up in 10 ml of carbon tetrachloride (CCl₄).

The concentrate was transferred to a clean 100-ml separatory funnel. The beaker was rinsed with a small amount of CCl₄ and added to the extract in the separatory funnel. The final volume was between 20 and 25 ml. One millilitre of about 50% H₂SO₄ was added, shaken for 30 seconds and allowed to stand for 30 minutes. This procedure was repeated three times. At the end of the fourth 30-minute period, the hydrolysis was complete.

Nine millilitres of water was added and gently mixed. After separation of the layers, the bottom layer was drawn off and discarded. The upper aqueous layer was washed once with 10 ml of chloroform. The washed aqueous layer was poured into another clean 100-ml separatory funnel and shaken with 25 ml of diethyl ether to remove the chloroform. Unremoved chloroform would interfere with the determination at 225 millimicrons.

An aliquot of the aqueous layer was transferred directly into an UV cuvette for reading in a Philips PU 8620 UV/VIS/NIR spectrophotometer.

3.5.1 Spectrophotometric Reading and Calculation of Atrazine concentration

The absorbance of the aqueous layer as obtained in Section 3.5 was measured at 225, 240, and 255 m μ . For comparison, a cell filled with distilled water was used. The readings at 225 and 255 m μ were used for a background correction.

To determine the atrazine content, it was necessary to prepare a calibration curve using known amounts of atrazine. The calibration equation obtained was given by:

$$\text{Concentration, } C \text{ } (\mu\text{g/mL}) = \Delta \times 112.56 \quad 3.1$$

The measured absorbances give the net absorbance, Δ , by the following Equation:

$$\Delta = A^{240} - \left(\frac{A^{255} + A^{225}}{2} \right) \quad 3.2$$

where A^α = absorbance wavelength α , where $\alpha = 225, 240$ and 255 , in this case.

The net absorbance Δ was corrected by subtracting a blank value obtained for the reagents used. It was also necessary to carry out a blank test on an untreated sample. The blank values are often negative so that subtraction of a negative value corresponds to an addition of the representative figure.

Concentration of atrazine in ppm was then calculated using Jackson's (1962) relationship given by:

$$\text{Conc. of atrazine } (\mu\text{g/g}) = \frac{C}{v} \times \frac{V}{W} \quad 3.3$$

where V = volume (mL) of extractant,

v = volume (mL) of aliquot,

and W = weight (g) of soil.

3.6. Determination of physico-chemical properties

3.6.1. Soil texture

Forty (40) grammes of sieved air dried soil was dispersed in a 100-ml sodium hexametaphosphate solution and the various particle fractions determined using Bouyoucos' (1962) Hydrometer method.

3.6.2. Bulk density

The Core method (Blake and Hartge, 1986) was used to determine the bulk density. Undisturbed core samples were weighed, dried in the oven at 105°C for 2 days and reweighed. Bulk density of the soil was found by finding the ratio of the dry weight of the soil to its volume.

3.6.3. Soil pH and organic carbon

Soil pH was measured in 1:1 soil-water suspension and 1:2 soil-0.01M CaCl₂ suspension using a Glass electrode-Calomel electrode (McLean, 1982) MV 88 Practronic pH meter.

The organic carbon content was determined using the Walkley-Black wet combustion

procedure (Nelson and Sommers, 1982). A 0.5 g soil sample was weighed into a 250 ml volumetric flask. Ten millilitres of 2N $K_2Cr_2O_7$ solution and 2 ml of conc. sulphuric acid were added. Digestion was allowed for 30 minutes and the dichromate solution remaining was titrated against 0.2 N ammonium ferrous sulphate using barium diphenylamine as indicator.

3.6.4. Saturated hydraulic conductivity (K_s)

The saturated hydraulic conductivity (K_s) of the various soil depths was determined using the Constant Head and the Falling Head Methods (Klute and Dirksen, 1986), the latter being used for less permeable layers.

For the Constant Head Method, samples of soils were taken with metal cores 10 cm long and 5 cm diameter allowing about 4 cm of space above the soil surface in the core. The soil was presaturated overnight by wetting from the bottom. A constant head of water was maintained on the soil using the Marriote arrangement. The head of water was noted. The volume of water flowing through the soil per unit time was recorded and the K_s value calculated using the Darcy's relationship given by

$$q_w = \frac{Q}{At} = -K_s \frac{\Delta H}{\Delta L} \quad 3.4$$

The K_s value is therefore given by

$$K_s = \frac{QL}{At(H_2 - H_1)} \quad 3.5$$

where, A = the cross sectional area (m^2) of the sample,

L = the length (m) of the sample,

Q = the volume (m^3) of water flowing through the sample in a unit time, t (s), and

$\Delta H = (H_1 - H_2)$ = hydraulic head difference imposed across the soil sample (m).

The measurement of K_s using the Falling Head Method, was also based on the direct application of the Darcy equation. A hydraulic head difference was imposed on the saturated soil column, and the resulting flux of water measured. The saturated hydraulic conductivity is given by:

$$K_s = \left(\frac{\alpha L}{A t} \right) \cdot \ln \left(\frac{H_0}{H_1} \right) \quad 3.6$$

where α = cross-sectional area of the water column (m^2)

H_0 = hydraulic head at time $t = 0$ (m)

H_1 = hydraulic head after a known time period (m)

3.7 Determination of adsorption atrazine by soils

Atrazine sorption to soil was measured using batch equilibration techniques (Clay *et al.*, 1994). Two grammes of soil contained in a glass bottle with teflon-lined screw cap was shaken in twenty millilitres of atrazine in 5 mM $CaCl_2$ solution with concentrations 1.25, 2.5, 3.75, 5, 7.5 and 10 $\mu g/mL$ for 2 hours (Briggs, 1981). These treatments were done in triplicate.

The suspension was centrifuged, filtered and the solution concentration measured by u.v. spectroscopy at 222 $m\mu$ against a soil blank (i.e. untreated soil) shaken with 20 mL of 5 mM $CaCl_2$

solution. The absorbances of the various standard solutions (i.e. 1.25 - 10 $\mu\text{g/ml}$) were also determined. The difference in amounts between the initial and the final solution was assumed to be the amount of atrazine adsorbed by the soil. The sorption coefficient, K_d , was obtained from the slope of the plot of amount of atrazine adsorbed against the amount remaining in solution.

3.8 Atrazine recovery and dissipation

The percentage of atrazine recovered, A_{rec} , defined as the total mass (μg) of atrazine within the 0.8-m profile expressed as a percentage of the mass of applied atrazine, was calculated using the following relationship:

$$A_{rec} = \left(\frac{C \times \rho_b \times V}{M_o} \right) \times 100 \quad 3.7$$

where C = the concentration of atrazine measured in the soil ($\mu\text{g/kg}$)

ρ_b = bulk density (kg/m^3)

V = volume of soil = area x layer depth (m^3)

M_o = mass of active ingredient of atrazine applied (μg)

The dissipated atrazine, A_{dis} (%), was then obtained by subtracting the per cent of atrazine recovered from the percentage of atrazine applied (100%). That is,

$$A_{dis} = 100 - A_{rec} \quad 3.8$$

3.9 Soil water measurements

Apart from the determination of Atrazine in the soil, measurements of soil water were also made by the Neutron scattering technique, using a Neutron Moisture Gauge with Americium-241 Be as neutron source. These measurements were made before commencement of experiment and at 2 days intervals after the commencement. Count ratios were converted to volumetric water contents using the calibration equations determined for the various depths and presented in Table 3.2.

Table 3.2 Neutron probe calibration equations for the various soil depths

Depth (m)	Calibration Equation	R ² value
0-0.2	$\Theta_v = 0.5912 \times \text{CR} - 0.157$	0.94
0.2-0.3	$\Theta_v = 0.6207 \times \text{CR} - 0.216$	0.81
0.3-0.4	$\Theta_v = 0.5800 \times \text{CR} - 0.183$	0.83
0.4-0.5	$\Theta_v = 0.5869 \times \text{CR} - 0.172$	0.92
0.5-0.8	$\Theta_v = 0.5842 \times \text{CR} - 0.168$	0.76

where CR = count ratio (the ratio of the counts per minute to the standard count), and

Θ_v = volumetric water content (m^3/m^3).

3.9.1 Soil water storage

Soil moisture storage, S_z (m) in a layer of soil of depth z , at time t , was calculated from the following relationship:

$$S_z = \sum_{i=1}^n \theta_{vi} \cdot \Delta z_i \quad 3.9$$

where i is the layer counter, Δz is the layer thickness (m), and z is the layer depth (m).

The change in water storage of a particular layer between times t_1 and t_2 was calculated as:

$$\Delta S = S_z(t_1) - S_z(t_2) \quad 3.10$$

CHAPTER FOUR

4.0 RESULTS AND DISCUSSION

4.1 Soil chemical and physical properties

The soil pH, organic carbon and the particle size fractions of the soil are presented in Table 4.1, whilst the variation of bulk density with depth is shown in Fig. 4.1. The soil was predominantly sandy clay loam in the upper 0.5 m and sandy clay in the 0.5-0.8 m layers. The clay content generally increased with depth as the sand content decreased. Variation in silt content with depth was minimal compared with the other fractions.

Table 4.1 Some physico-chemical properties* of the soils

Depth (m)	pH		Organic Carbon (%)	Particle Size Fraction (%)		
	1:1 ¹	1:2 ²		Sand	Silt	Clay
0-0.1	4.6 ±0.2	4.2 ±0.2	0.61	70.52	2.59	26.89
0.1-0.2	4.6 ±0.2	4.2 ±0.2	0.54	68.50	3.81	27.69
0.2-0.3	4.6 ±0.2	4.3 ±0.2	0.38	64.40	6.18	29.42
0.3-0.4	4.6 ±0.2	4.3 ±0.2	0.32	63.05	6.20	30.75
0.4-0.5	4.6 ±0.2	4.2 ±0.2	0.22	61.63	6.23	32.14
0.5-0.6	4.6 ±0.2	4.2 ±0.2	0.26	58.66	5.04	36.30
0.6-0.7	4.7 ±0.1	4.3 ±0.2	0.22	54.58	3.92	41.50
0.7-0.8	4.7 ±0.1	4.3 ±0.2	0.19	57.72	5.00	37.28

* All values are means of 9 observations

1 Soil pH measured in 1:1 soil:water ratio

2 Soil pH measured in 1:2 soil:0.01 M CaCl₂ ratio.

± Standard error of the mean

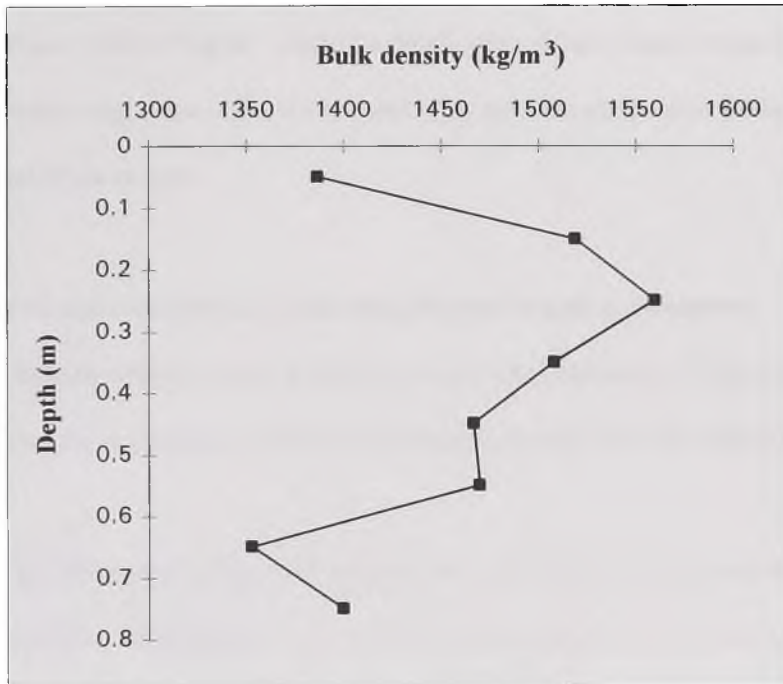

Fig. 4.1 The variation of bulk density with depth.

The average organic carbon content of 0.61% in the surface 0.1-m layer, could be described as being low (Troiano *et al.*, 1993). The value dropped rapidly with depth to 0.19% at 0.8 m. The average bulk density of the 0.8-m depth profile was $1.46 \times 10^3 \text{ kg m}^{-3}$, and ranged between $1.35 \times 10^3 \text{ kg m}^{-3}$ and $1.56 \times 10^3 \text{ kg m}^{-3}$. From the distribution of bulk density values (Fig. 4.1) it appears there is some compaction in the 0.2 m depth. This apparent compaction is likely to impede water movement in the profile.

4.2 Soil water distribution under the different irrigation treatments

Pesticide transport in soils is primarily due to water movement. Thus, the movement of soil water during the experiments is first of all discussed as a prelude to the fate of atrazine in the field soils.

The differences in irrigation frequencies were reflected in the water content profiles depicted in Figs. 4.2-4.4. In Treatment 1 (T1) (Fig 4.2), the application of 50 mm on day 1 resulted in appreciable increase in water contents measured in the top 0.5 m on day 3. On day 9 before the next water application, the water contents of the top layers had reduced whilst the lower 0.3 m layers had increased in water content. Upon addition of 50 mm, the profile became wet up to 0.7 m on day 11. Before that last 50 mm water application (day 17), there had been uniform water content within the profile and ranged between 0.21 and 0.23 cm^3/cm^3 . The last application of water resulted in a uniform increase in water contents at all depths (day 19). On the final day of water measurement, the top 0.7 m depth decreased in water content, with the margin decreasing with depth.

Treatment 2 (T2) (Fig. 4.3) exhibited consistent successive increment in water contents

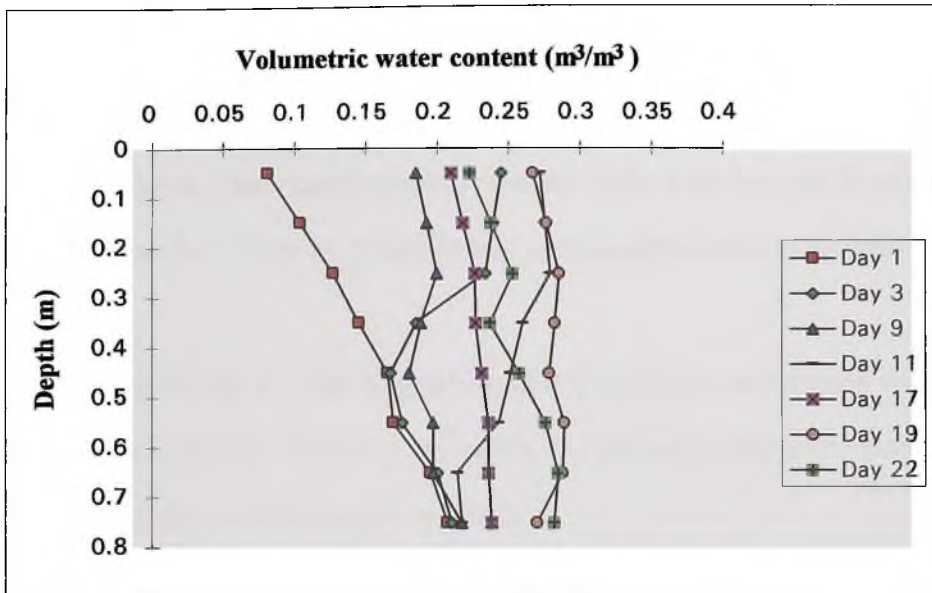

Fig. 4.2 Variation of soil moisture profiles under "Low Frequency Irrigation" (T1)

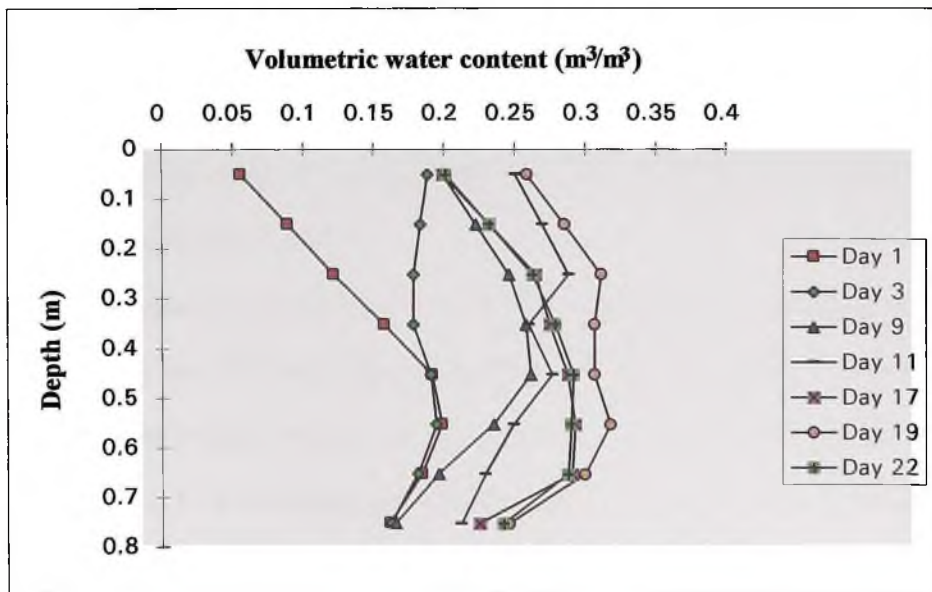

Fig. 4.3 Variation of soil moisture profiles under "Medium Frequency Irrigation" (T2)

up to day 19 and decreased on day 22 when irrigation had ceased. Although all the profiles measured are not shown, water contents generally decreased after irrigation until the next water application, as obtained in T1. Like T1, T2 also resulted in appreciable increase in the water content at the 0.8 m depth.

Treatment 3 (T3) (Fig. 4.4) also resulted in consistent increase in water content, especially in the top 0.7 m layers, up to day 19 and a decrease on day 22. The water content in T3 at 0.7-0.8-m layer did not change appreciably during the experiment.

Generally, fluctuations in soil water content in response to irrigation were more pronounced in T3 than T1 and T2. Thus, whereas Treatments 1 and 2 resulted in significant increases in water contents within the entire 0.8-m depth, the increase in water content produced by T3 was only substantial up to 0.4-0.5 m layer by day 11. It was likely that at the end of the experiment, an appreciable amount of water might have moved down in T1 and T2 to greater depths beyond the 0.8 m depth through deep drainage, although no data were taken to confirm this. Moreover, increases in water contents at the 0.8 m depth were higher in T1 and T2 than T3 in which much of the water was held within the top 0.8 m.

It is remarkable to note that T1 and T2 were more effective in increasing the soil water content at all depths than T3. Redistribution process was more pronounced in T1 than the other treatments because the irrigation interval was wide enough to make it noticeable. Higher amounts of water application in T1 at low frequencies ensured greater movement of water from the surface to the subsoil.

On day 1, water contents of all the treatments increased approximately steeply with depth upon irrigation. However, in subsequent irrigations the increase in water content with depth was

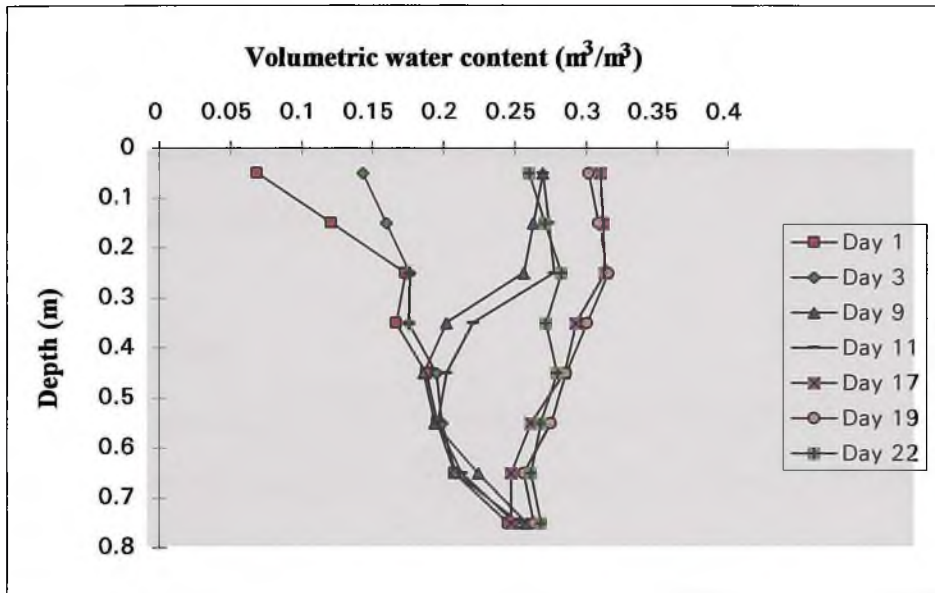

Fig. 4.4 Variation of soil moisture profiles under "High Frequency Irrigation" (T3)

quite uniform throughout the profile. This may be due to the effect of hysteresis which is important especially in intermittent irrigation.

A close observation of the profiles below 0.25 m depth shows a slight increase in water contents in T2 than T1 because differences between the initial and final water contents were slightly higher in T2 than T1. This is contrary to the observation made by Nielsen *et al.* (1967) that soil water contents increased with increasing incremental irrigation amounts. The deviation observed may be attributed to variability in soil moisture loss from the surface and beyond the 0.8 m depth. This is discussed later in Section 4.4.

4.3 Soil water storage

Soil water storage, defined as the product of the volumetric water content and the layer depth (See Equation 3.9), is as important as its movement since chemicals can move in soils by diffusing in the soil water. Comparison of soil water storage under the various treatments may therefore help us know which treatment may facilitate herbicide transport.

The cumulative net water storage, obtained by summing all the net water storage values (See Equation 3.10) for the various irrigation treatments and at different times, are shown in Fig. 4.5. In all treatments, the incremental water application led to increase in soil water storage. This is consistent with the findings of Nielsen *et al.* (1967) and Troiano *et al.* (1993). Generally, as irrigation amount per event increased (from T3 to T1), soil water storage increased and the rate of increase was higher upon addition of water to T1 than T2, or T3. This is expected because the amount of water added per irrigation to T1 was higher than T2 or T3.

The patterns of water storage over time reflected the mode of water application. For T1, the

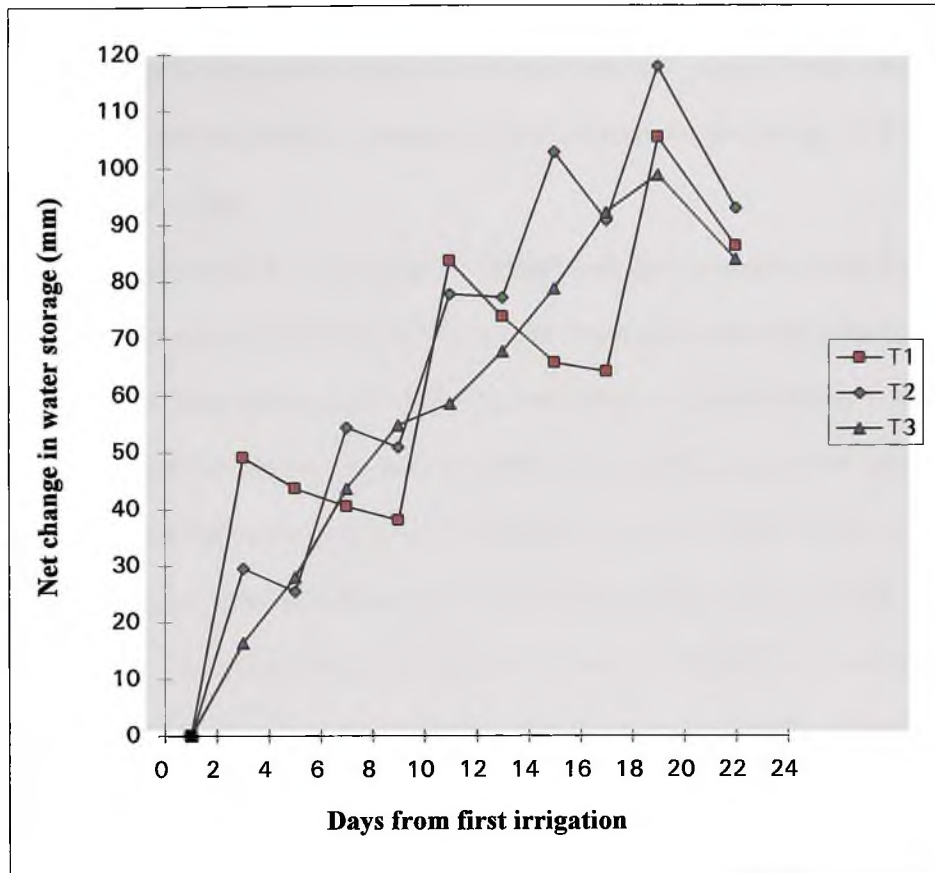

Fig. 4.5 Cumulative change in water storage within the soil profile (0-0.8 m)

net soil water storage increased sharply after each application of water and this decreased gradually until the next application. On the other hand, water storage for T3 increased quite monotonically except for the end of the experiment when there was a drop in water storage. The situation for T2 was not intermediate. At almost all times (except the beginning), T2 always had the highest net water storage.

In Fig 4.5, the increase in net soil water storage with time was quite linear for T3 and increased steadily throughout the experiment since water was applied after each water content measurement. In the other treatments (T1 and T2), reductions in storage were observed between irrigation days. These losses were due to deep percolation and, probably, evaporation since runoff was prevented. (Although the plots were covered with plastic sheets, the sheets were not in contact with the soil surface due to the embankments at the peripheries of the plots and also the presence of the access tubes. A separate study done earlier on the field revealed that some amount of evaporation occurred on the soil covered with the plastic sheet). The reductions in storage were higher in T1 due to longer period between irrigation events during which redistribution might have been complete and evaporation might have been substantial.

In the earlier study by Nielsen *et al.* (1967), they observed that the amount of water remaining in the soil after redistribution for a period of time following infiltration depended not only on the size of the repeated water application but also on the amount of water passing through the profile. They observed that after equal amount (18 inches) of water had infiltrated the plots of both treatments involving 6-inch applications and 2-inch applications, the amounts of water remaining after redistribution were equal. In this study, after all treatments had received 150 mm of water, comparisons of the soil water storage of the various treatments at the end of the experiment (i.e. day

22) showed almost equal final water storage values. The small differences may be due to various experimental errors or variable losses of water through deep percolation and evaporation.

4.4 Losses of soil water

The amount of water lost under each treatment at any time was obtained by subtracting the amount of water stored in the soil from the total amount of irrigation water applied. Figure 4.6 shows the cumulative amounts of water lost in the various irrigation treatments. As the water storage increased with time, so also did the water loss. However, T3 gave the highest loss followed by T1 and then T2, a trend just opposite to the water storage.

A greater proportion of the amount of water lost in T3 was probably due to evaporation since this treatment received small incremental water applications at the highest frequencies. This ensured that the soil surface was wet throughout the experiment resulting in the highest evaporation losses. Hillel (1980) proposed that an irrigation regime having an excessively high irrigation frequency could cause the surface to remain wet and the first stage of evaporation (during which higher amounts of evaporation do occur) would persist most of the time.

Evaporation in T1 and T2 cannot be ruled out but it is likely to be lower because water loss by evaporation from a single deep irrigation is generally lower than that from several light water applications (Hillel, 1980).

Water losses through deep percolation, are likely to be higher in T1 and T2, in accordance with Hillel's theory that water losses due to percolation are likely to be greater for larger irrigation applications than for smaller ones. Watts *et al.* (1991) have also noted small deep percolation losses with small irrigation amounts.

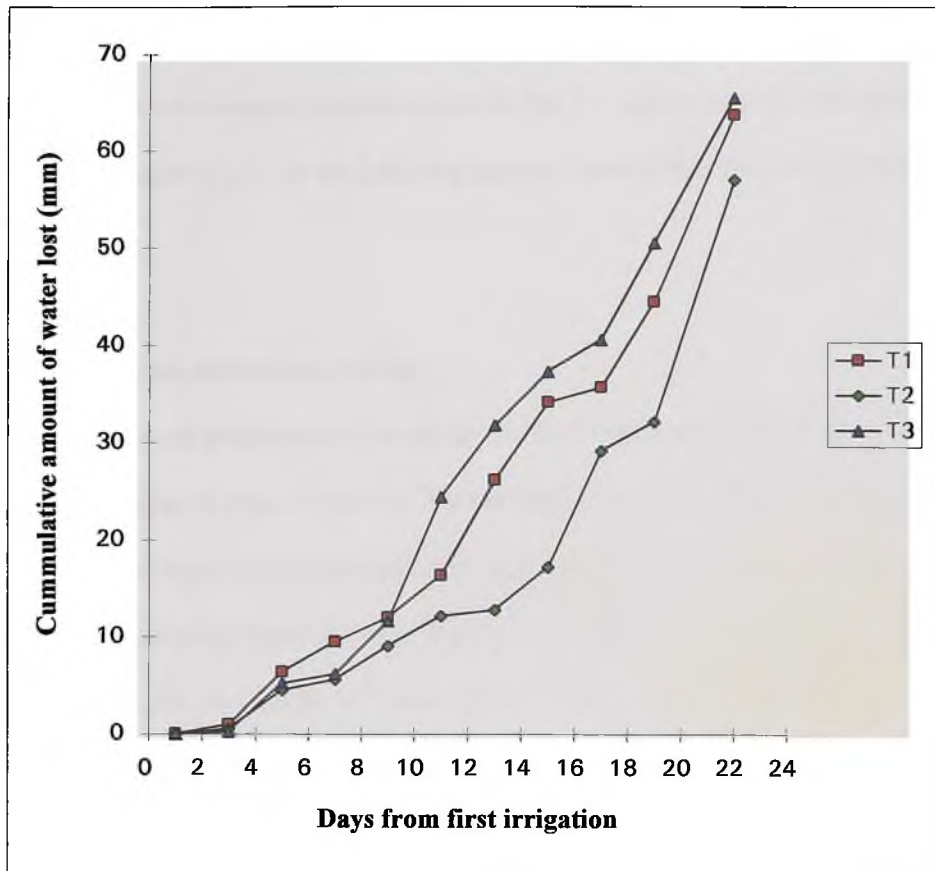

Fig. 4.6 Water loss under the various treatments from the soil profile (0-0.8 m)



4.5 Atrazine transport in soils

Having discussed the relevant aspects of water transport in the previous section, it is pertinent now to discuss atrazine transport under the different irrigation treatments. As a reminder, the systems diagram for the fate of herbicides shown in Fig. 2.1 depicts several components of the fate of applied herbicide in soil. In the following sections, some of the relevant components will be discussed.

4.5.1 Atrazine distribution in soils

The distribution of atrazine within the soil profile for the various treatments at selected days of sampling are presented in Figs. 4.7 and 4.8. Data points represent the mean of all samples taken from triplicate plots of each irrigation treatment at the given depths. The amount of surface-applied herbicide in the topsoil at any particular time is of primary interest since it determines the bioactivity of the chemical and also the amounts that are available for transport in the soil profile.

Two days after atrazine application when each treatment had received only one irrigation application, the least irrigation amount gave the highest concentration of atrazine in the top 0.1 m depth. However, there was some irregularity between the highest and the intermediate initial irrigation amounts. This inconsistency is difficult to explain, but could be ascribed to soil variability. The high concentration in T3 may be attributed to the accumulation of the herbicide as the irrigation amounts decreased. The high amount of water applied in T1 on the first day may have reduced the contact time of the chemical with the soil and, therefore, decreased adsorption of atrazine (Green *et al.*, 1995).

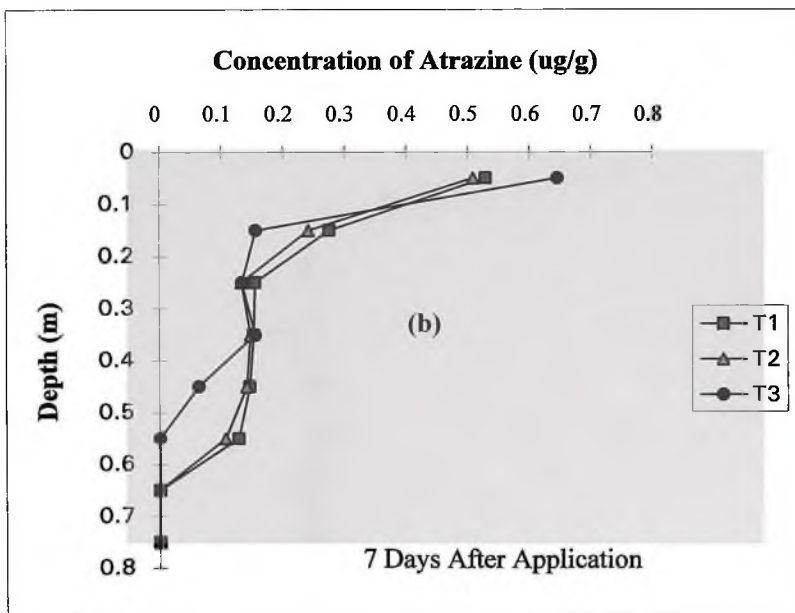
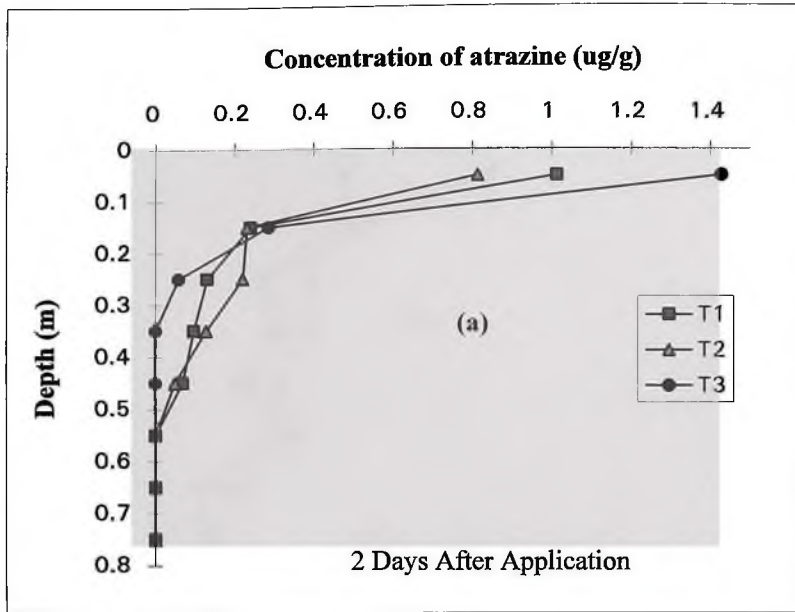

Fig. 4.7 Distributions of atrazine in the soil within the first week of application.

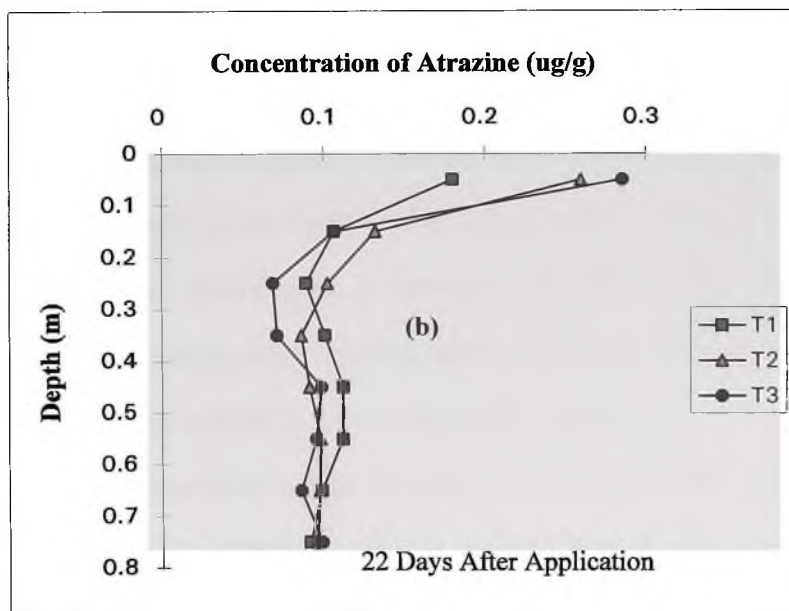
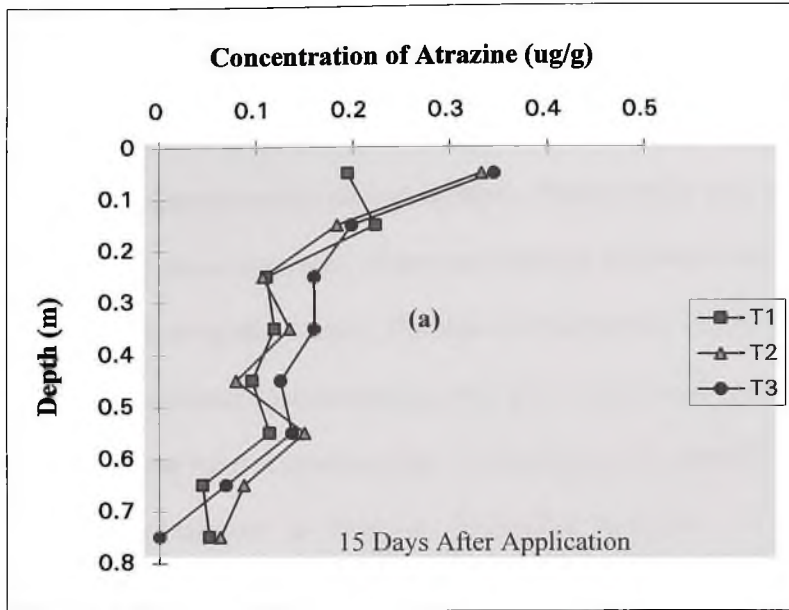

Fig. 4.8 Distributions of atrazine in the soil, 15 and 22 days after application.

On day 2, the concentration of atrazine was zero at 0.25 m depth under T3 whilst under T1 and T2, atrazine was detectable within the 0.45 m depth. Similar trends were noted 7 days after application, even though the concentration of atrazine decreased with depth compared with day 2. Day 15 provided an interesting observation. The high and intermediate irrigation frequencies had almost the same concentrations of atrazine in the top layer, whilst the low irrigation frequency treatment (T1) had the least atrazine concentration. On day 22, the concentration of atrazine in the top layer decreased consistently as irrigation frequencies decreased. In general, atrazine concentrations in the top 0.1 m depth decreased with time in all the treatments. However, the rate of decrease was more rapid in the first 15 days but decreased from day 15 to day 22. Generally, the variation in the concentrations of atrazine with depth and time was more pronounced in the top layers. The concentrations in the deeper layers were remarkably different with irrigation frequencies, and the variations appeared more or less inconsistent with time and depth.

Similar decrease in atrazine concentration with depth and time has been observed in some field studies by some researchers (Starr and Glotfelty, 1990; Wehtje *et al.*, 1984). For instance, Wehtje *et al.* (1984) found that, after 2 growing seasons, samples collected at a depth of 1.5 m had an average recovery rate of 0.072% of the surface applied atrazine.

The distribution of atrazine under the various treatments at the end of the experiment (22 days after application; Fig. 4.8b) is of special significance since all treatments had then received equal amounts (150 mm) of water. After all the treatments had received 150 mm of water, it was deduced that atrazine concentrations in the various treatments in the top 0.1 m decreased but increased in the deeper layers as irrigation amounts per event increased from T3 to T1. In the deeper layers, however, inconsistencies were observed among the treatments. The peak

concentrations in T1, T2 and T3 in the deeper layers occurred at 0.5 m, 0.5-0.6 m and 0.4-0.5 m, respectively, and the respective atrazine concentrations at these peaks were 0.113, 0.099 and 0.099 $\mu\text{g/g}$.

4.5.2 Comparison of atrazine movement in the various treatments

The discussions above have described the general patterns of atrazine distribution under the different treatments. To assess, in more quantitative terms, the effect of different irrigation frequencies, a criterion of the depth to the location of the centre of mass, i.e. the depth at which the centre (50%) of recovered atrazine mass was located (Troiano *et al.*, 1993), was employed. It was calculated for each treatment, and used as an index for determining the depth of movement.

Generally a significant ($P < 0.01$) positive linear relationship was observed between the depths to the centres of mass and time (Fig. 4.9). At the end of the experiment, the centre of mass of atrazine in T1 was deeper (0.41 m) than those of T2 and T3 (0.34 m). Differences observed on days 2, 7, and 15 after application may be due to differences in water movement caused by different cumulative amounts of irrigation water applied. The low frequency irrigation with highest irrigation depth per event might therefore have resulted in deep percolation and hence more atrazine movement in the profile.

In a similar study by Troiano *et al.* (1993), a significant linear relationship was observed when depth to centre of mass was plotted against amount of percolated water. Lange and Bendixen (1981) as cited by Troiano *et al.* (1993) reported less downward movement of pre-emergent herbicides in the treatments that provided small rather than large increment of water.

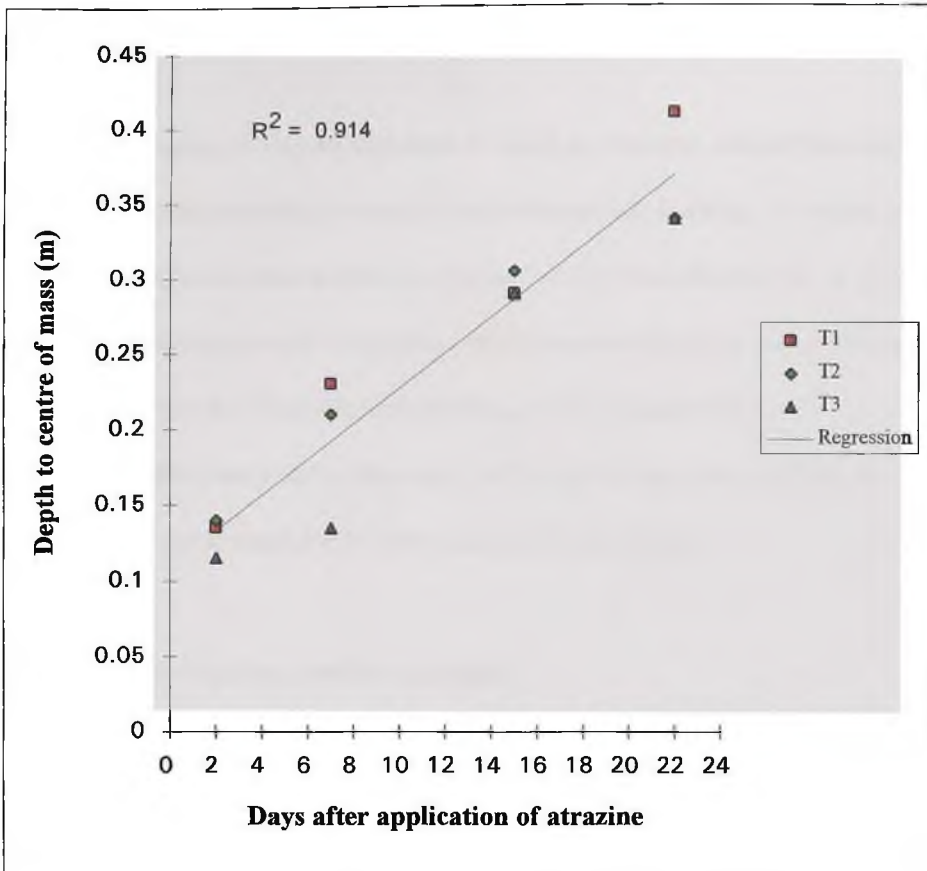

Fig. 4.9 Relationship between irrigation frequency and atrazine movement

From the foregoing, it may be important to adopt an irrigation practice that retains more water in root zone of crops, especially in areas that are vulnerable to leaching. In reality, water lost to deep percolation becomes unavailable to crops and it also increases the risk of groundwater contamination since adsorption and dissipation rates of atrazine dissolved in soil water at deeper layers are low (Isensee *et al.*, 1990; Wagenet and Rao, 1990; Troiano *et al.*, 1993). Comparing the treatments in this study, T2 might be the most appropriate irrigation treatment at the site since it stores much water and leaches less atrazine.

4.6 Factors affecting atrazine movement.

Although several factors are known to affect chemical transport as discussed in the literature review (Chapter 2, Section 2.2.1), only the interaction of atrazine with the soil colloid and the dissipation are considered in this study. The following section will focus on the sorption of atrazine at different depths of soil and dissipation of atrazine under the various irrigation treatments.

4.6.1 Atrazine sorption

The data discussed so far regarding atrazine distribution and/or transport were based on extraction procedure (Section 3.5) that essentially removed almost all atrazine from the sampled soil. Under field conditions, however, atrazine would be partitioned between the soil solution and soil colloidal phase. Therefore, it is of scientific interest and for modelling purposes, to assess how atrazine may be partitioned in this way.

The adsorption isotherms of atrazine for the top 0.4 m are presented in Fig. 4.10.

The sorption coefficient, K_d , values were $1.93 \times 10^{-3} \text{ m}^3 \text{ kg}^{-1}$ and $0.55 \times 10^{-3} \text{ m}^3 \text{ kg}^{-1}$ for the top 0.2 m and 0.2-0.4 m layers, respectively. Although no sorption analyses on the other layers (0.4-0.8 m) were done, their K_d values were expected to be lower than $0.55 \times 10^{-3} \text{ m}^3 \text{ kg}^{-1}$. This is because the content of organic matter, which may be responsible for adsorption of a greater proportion of atrazine (Brouwer *et al.*, 1990; Burns *et al.*, 1973), decreased with depth (See Table 3.1).

In spite of the fact that clay content increased with depth and that a highly positive correlation between adsorption and clay content has been observed by some researchers (Harper, 1988; Ladlie *et al.*, 1976; Savage, 1976), its contribution to sorption might have been minimal since the predominant clay mineral in the soil studied was Kaolinite which has a low sorption capacity (Ahenkorah *et al.*, 1994; Brammer, 1962).

Thus, once atrazine leaches from the top 0.2 m of the soil, there is a high risk for its movement deeper in the profile because of minimal adsorption in the lower depths (Clay *et al.*, 1994).

4.6.2 Atrazine recovery and dissipation.

The amount of atrazine recovered at a given time after application may be a function of its persistence in the soil environment. The persistence of herbicides in the soil profile is of agronomic and environmental importance because it determines their contamination potential (Petach *et al.*, 1991) and also influences the activity of the herbicides in the root zone.

The mass of atrazine recovered relative to the mass applied with time for all the

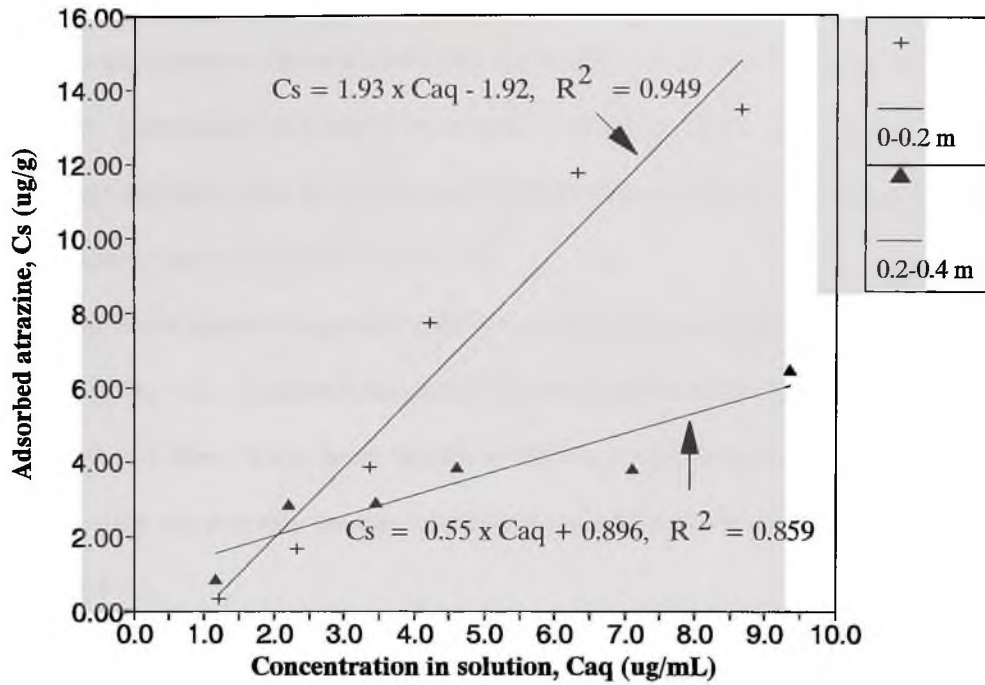

Fig. 4.10 The Adsorption isotherms for atrazine at 0-0.2 m and 0.2-0.4 m depths.

treatments together is presented in Fig. 4.11. In general, a significantly ($P < 0.01$) negative linear relationship was observed between per cent mass of atrazine recovered and elapsed time. The negative relationship indicated loss of atrazine from the profile. On the first day of sampling, the atrazine recovery decreased in response to an increase in irrigation depth. That is, as irrigation amounts increased, soil water contents also increased. On the final day (22 days after application), the per cent recovery was in the order $T1 < T3 < T2$.

The dynamics of atrazine dissipation under the various treatments during the experimental period is shown in Fig. 4.12. In general, the rate of dissipation (given by the slope) decreased and became constant with time. Since losses through runoff were negligible, the dissipation of the herbicide in this study was probably through volatilization, degradation and movement beyond the study zone (0-0.8 m).

Volatilization of atrazine in field soils has been reported (Wienhold and Gish, 1994). Volatilization is normally highest on the soil surface (Walker *et al.*, 1982) and from moist surfaces (Aldrich, 1984; Smith, 1982; Khan, 1980). Thus, losses due to volatilization in T3 may be the highest. On day 1, however, the increased water content in T1 resulting from highest irrigation might have caused more volatilization in T1 followed by T2 and T3.

On the final day the possible deep percolation in T1 might have caused more atrazine to be transported beyond the 0.8 m whilst high volatilization and biodegradation in T3 may be possible reasons for lower mass recovery than T2.

Based on decay equations with reported half-life values of 60-70 days for atrazine (Khan *et al.*, 1981; Helling *et al.*, 1988; Isensee *et al.*, 1990), the expected amount of atrazine available for leaching 22 days after application in the soil of depth 0.8 m would be 78-80% of the initial amount.

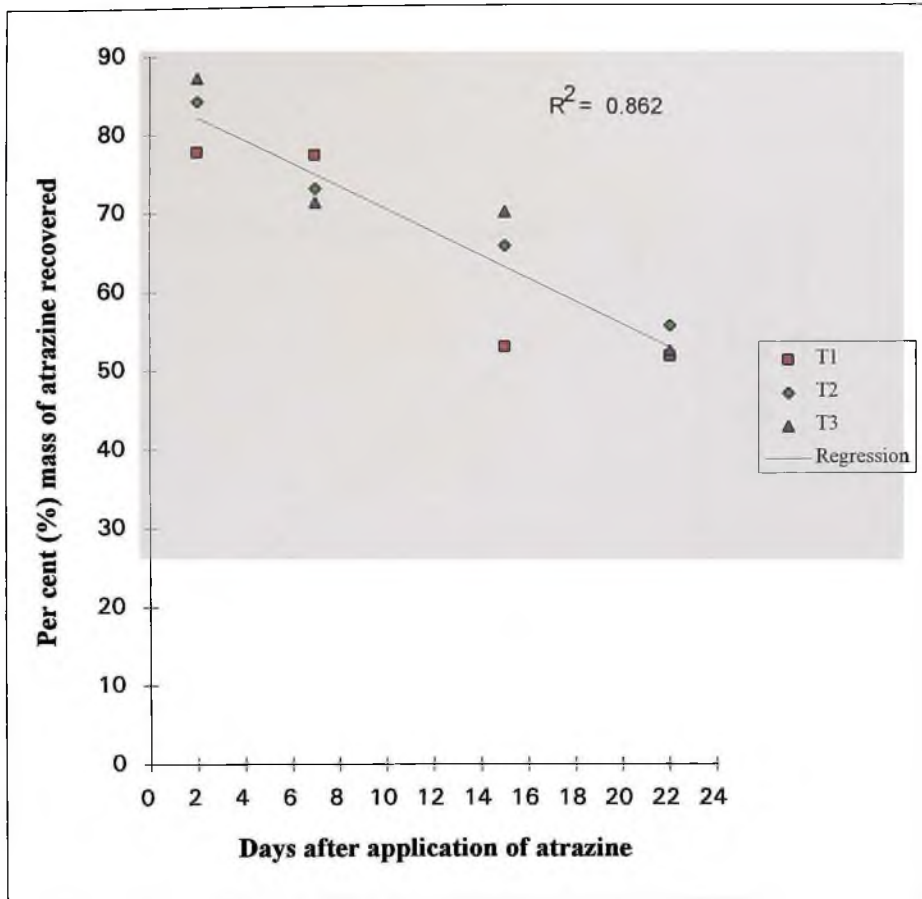

Fig. 4.11 Relationship between per cent mass of atrazine within the soil profile a irrigation treatments.

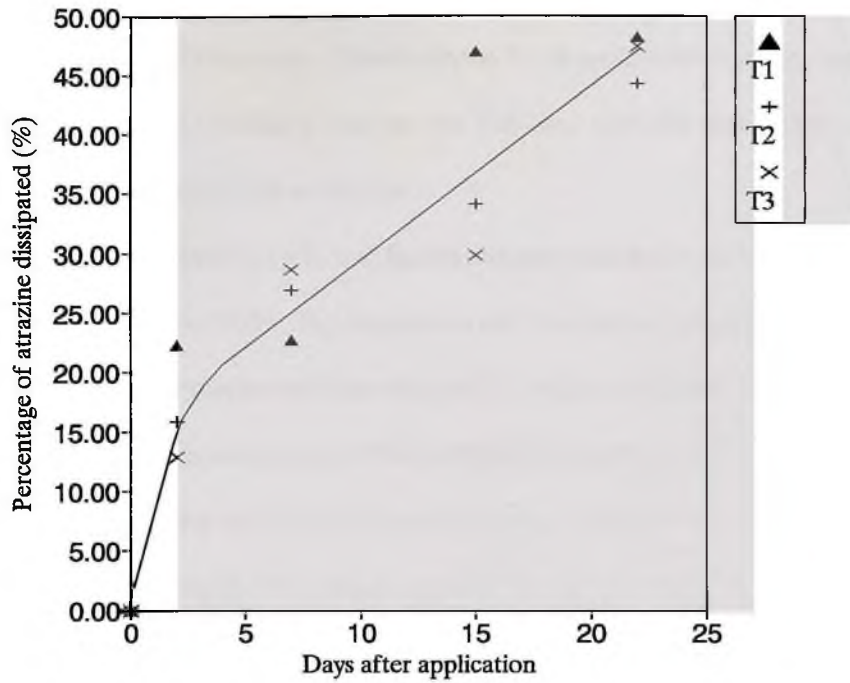

Fig. 4.12 Dynamics of atrazine dissipation in soil.

In this study, total atrazine in the 0-0.8 m depth 22 days after application was between 53 and 57%. Thus, it is suspected that atrazine might have leached below the 0.8 m study zone. Isensee *et al.* (1990) also observed that the amount of atrazine in the 1.5-m profile 200 days after application was far less than the expected amount based on the half lives of 60-70 days. This reduction was attributed to leaching beyond the study zone.

Degradation is one of the principal factors reducing atrazine levels in soil and soil solution (Armstrong and Chesters, 1968). The degradation may be chemical, photochemical or microbial. Photodecomposition in *s*-triazines has been reported by Jordan *et al.* (1963) and it normally occurs on the soil surface. Guenzi and Beard (1976) found that microbial degradation decreased as the soil moisture decreased. Thus, the High-Frequency Irrigation treatment (T3), which maintained wet surface throughout the experiment, probably resulted in more microbial degradation of atrazine, followed by T2 and T1. The microbiological processes in soil is dominant in the topsoil or root zone due to optimum conditions and more organic matter (Wagenet and Rao, 1990), and a decrease in atrazine degradation with depth has been observed by Harris *et al.* (1969) and Adams and Thurman (1991).

CHAPTER 5**5.0 MODELLING TRANSPORT OF WATER AND ATRAZINE IN A FIELD SOIL.****5.1 Introduction**

In the previous chapter, the general patterns of transport of Atrazine in a field soil were discussed. Understanding such patterns is important for the general application of such chemicals. However, in order to predict the extent and amount of chemicals that moved from the source of application to another point of interest, modelling of the transport process becomes important. Furthermore models are useful for generating data that would be very time consuming and costly to obtain by standard experimental procedures (Greenwood and Walker, 1990).

In the literature, many models have been developed to assess the fate of pesticides in the soil environment. These include the "Chemical Movement in Layered Soil", CMLS (Nofziger and Hornsby, 1986), "Leaching Estimation And Chemistry Model", LEACHM (Wagenet and Hutson, 1989), "Pesticide Root Zone Model", PRZM (Carsel *et al.*, 1984). These models differ in complexity and may range from simple ones based on mass flow (Burns model, see Section 2.3.1) to Convective dispersion Equations (CDE).

The choice of a particular type would depend on factors such as parameterisation, level of details to be represented in the model, etc. The complete CDE, although known to lead to good predictions, may have some drawback, especially the need for detailed numerical techniques and computing skills to solve large matrices generated from non-linear equations.

In this chapter, an attempt is made to develop and test a simple chemical transport model

based on the concept of mass flow and using the simple numerical procedure of Koorevaar *et al.* (1983) to solve the aspect of water flow in the field soil.

5.2 Materials and methods.

5.2.1 Theoretical Framework for describing water flow in soils

Pesticide transport in soils is primarily due to water movement. Thus, the ability to assess the extent of pesticide transport will inevitably depend on how well water movement is described.

The flow of water through a rigid porous medium, such as soil, can be described mathematically by the Darcy and continuity equations. Darcy's law which describes the flux density, q_w , (m s^{-1}) of water can be written as:

$$q_w = -K_z(\theta) \frac{\partial H}{\partial z} \quad 5.1$$

where $K_z(\theta)$ is the hydraulic conductivity function (m s^{-1}) of the soil at depth z , H is the soil hydraulic potential (kPa) = $h - z$, where h is the matric potential (kPa).

The matric potential (h) and the hydraulic conductivity (K_z) of the various depths can be expressed as a function of the soil water content according to Campbell (1974) as:

$$h(\theta) = h_e \left(\frac{\theta}{\theta_s} \right)^{-b} \quad 5.2$$

and

$$K(\theta) = K_s \left(\frac{\theta}{\theta_s} \right)^{2b+3} \quad 5.3$$

where θ_s is the saturated water content (m^3/m^3), $K(\theta)$, the water-dependent unsaturated hydraulic conductivity (m s^{-1}), h_e , the air entry water potential (m) and b is a constant (the Campbell's parameter for the soil). In this study, the value b was obtained from the texture, organic carbon content and the bulk density using an algorithm (RETFIT) developed by Hutson and Wagenet (1992).

The flux of water moving across the boundary between soil layers is calculated using a simple numerical scheme similar to that outlined by Koorevaar *et al.* (1983) (Fig. 5.1). For water transport from layer i to layer $i+1$, where i is a layer counter, an average hydraulic conductivity was estimated as the geometric mean of the values for the adjacent layers and the flux through the boundary estimated using:

$$q_{w(i+\frac{1}{2})} = -\sqrt{\left(K_{i+\frac{1}{2}} \cdot K_{i-\frac{1}{2}} \right)} \cdot \left(\frac{H_{i+\frac{1}{2}} - H_{i-\frac{1}{2}}}{\Delta z} \right) \quad 5.4$$

where $i-\frac{1}{2}$ and $i+\frac{1}{2}$ are positions on the top and lower boundaries of layer i (Fig. 5.1a). Equation 5.4 is generally applicable to water transport through any layer or across the boundary between any 2 layers of soil.

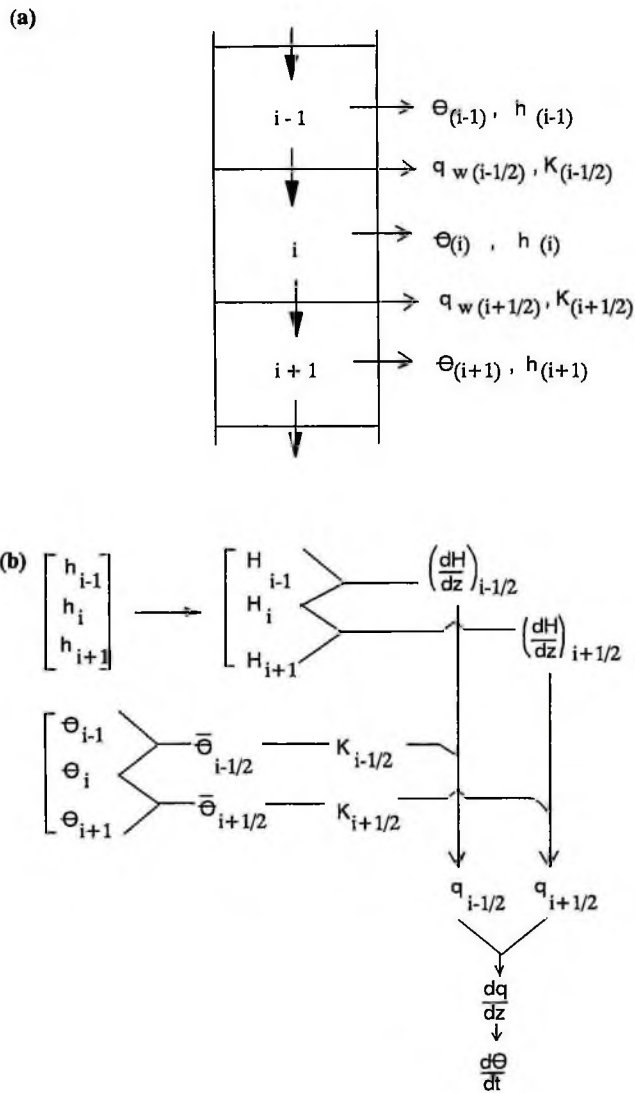

Fig. 5.1 Scheme for calculating soil water flow (Adapted from Koorevaar *et al.*, 1983).

The difference in water fluxes entering and leaving layer i leads to a change in water content of the layer. This process is summarised by the continuity equation as:

$$\frac{\partial \theta}{\partial t} = -\frac{\partial q_w}{\partial z} \quad 5.5$$

To solve Equation 5.4 for all soil layers requires knowledge of boundary values. In this study, the water flux at the upper boundary of the profile is the result of irrigation. It is further assumed that water in excess of Field Capacity will percolate downwards.

5.2.2 Modelling solute transport

Solute transport by convection or mass flow is usually considered synonymous with leaching (Khan, 1980) and can be described by the equation

$$q_c = q_w C \quad 5.6$$

where q_c is the flux of solute ($\text{kg m}^{-2} \text{s}^{-1}$) and C is the concentration of the solute (kg m^{-3}) in the soil solution. To extend the solute flow equation to account for herbicide transport, the following assumptions were made:

1. the soil profile consists of small discrete sections each of thickness 0.05 m;
2. initial water content and herbicide concentration in each soil increment is known;
3. all irrigation water infiltrates into the soil during an irrigation event;
4. evaporation was negligible;
5. except for adsorption, other chemical reactions are negligible; and

6. dissolved and adsorbed phases of the herbicides are in equilibrium, governed by linear adsorption isotherm, which is expressed as

$$C_s = K_d C_a q \quad 5.7$$

where C_s is adsorbed chemical on soil particles ($\mu\text{g/g}$), $C_a q$, the dissolved chemical concentration in soil solution ($\mu\text{g/cm}^3$) and K_d , the solute adsorption coefficient (m^3/kg).

The effect on pesticide-colloid interaction on solute transport is expressed as:

$$q_{cads} = \frac{q_c}{R} \quad 5.8$$

where q_{cads} is the flux of an adsorbable chemical (herbicide) and R is the dimensionless solute retardation factor defined as

$$R = 1 + \left(\frac{\rho_b K_d}{\theta_{FC}} \right) \quad 5.9$$

where ρ_b is the bulk density (kg m^{-3}) and K_d is solute adsorption coefficient ($\text{m}^3 \text{kg}^{-1}$) obtained from Equation 5.7.

The assumptions and the equations stated above were used to develop an algorithm coded in FORTRAN 77 (listed in Appendix A) and used to describe the movement of water and Atrazine in the field soil.

5.2.3 Some soil properties used in the simulations

The properties of the soil used in this model are summarised in the table below.

Table 5.1. The soil properties used in the simulations

Depth m	K_s cm/day	h_s cm	b	K_a cm ³ /g	ρ_b g/cm ³	θ_{rc}	θ_s	θ_i (cm ³ /cm ³)		
								(T1)	(T2)	(T3)
0-0.1	65.00	-4.02	4.93	1.93	1.39	0.30	0.47	0.08	0.06	0.07
0.1-0.2	19.70	-5.36	5.58	1.93	1.52	0.31	0.42	0.10	0.09	0.12
0.2-0.3	34.00	-6.09	6.51	0.55	1.56	0.30	0.41	0.13	0.12	0.17
0.3-0.4	49.08	-4.94	6.65	0.55	1.51	0.25	0.43	0.15	0.16	0.17
0.4-0.5	136.29	-4.16	6.83	0.55	1.47	0.25	0.44	0.17	0.19	0.19
0.5-0.6	42.74	-4.27	7.48	0.55	1.47	0.25	0.44	0.17	0.20	0.20
0.6-0.7	79.30	-2.63	8.01	0.55	1.35	0.27	0.49	0.20	0.19	0.21
0.7-0.8	15.10	-3.19	7.47	0.55	1.40	0.25	0.47	0.21	0.16	0.25

$\theta_i(T1)$, $\theta_i(T2)$ and $\theta_i(T3)$ are initial water contents of T1, T2 and T3, respectively.

5.2.4 Data sources

The main source of data for evaluating the water and solute transport model was taken from those discussed in Chapter 4. The measured water content and solute front obtained for the treatments were compared with those predicted by the model.

5.3 Results and discussion

5.3.1 Prediction of water movement and moisture profiles

The profiles of soil moisture content measured and predicted are presented in Figs. 5.2 - 5.4. In all treatments, the predicted water contents agreed with the observed on the first day of water application. However, some deviations in the predictions were noted, especially in the subsequent days.

In the Low Frequency Irrigation treatment (T1) (Fig. 5.2), the predicted values of the moisture content in the top 0.2-m layer were always higher than the measured values (with exception of day 1). Between 0.3 and 0.8 m, the predicted water content values agreed closely with the measured values on day 5. On day 11, the predicted values agreed with the measured values between 0.1 and 0.5 m depths. After the 11th day, the behaviour of the model was not consistent and its ability to predict the soil moisture profile was poor. On all days, the top 0.3 m had lower measured water content values than the predicted values.

In the Medium Frequency Irrigation treatment (T2) (Fig. 5.3), poor agreement between the predicted and the measured water contents was observed after the first day of irrigation. On day 5, the model predicted shallower water transport (up to 0.1-0.2 m depth) than the observed (0.3-0.4 m depth). In the lower 0.4 m, however, the predicted and measured values agreed very well. At all times, the top 0.3 m had lower measured values than the predicted, similar to T1.

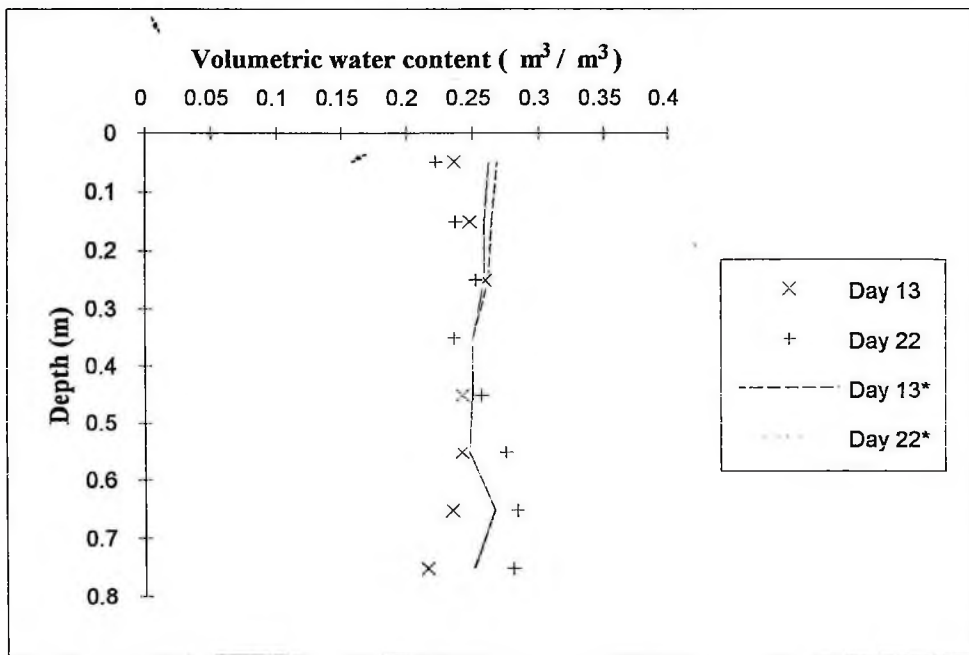
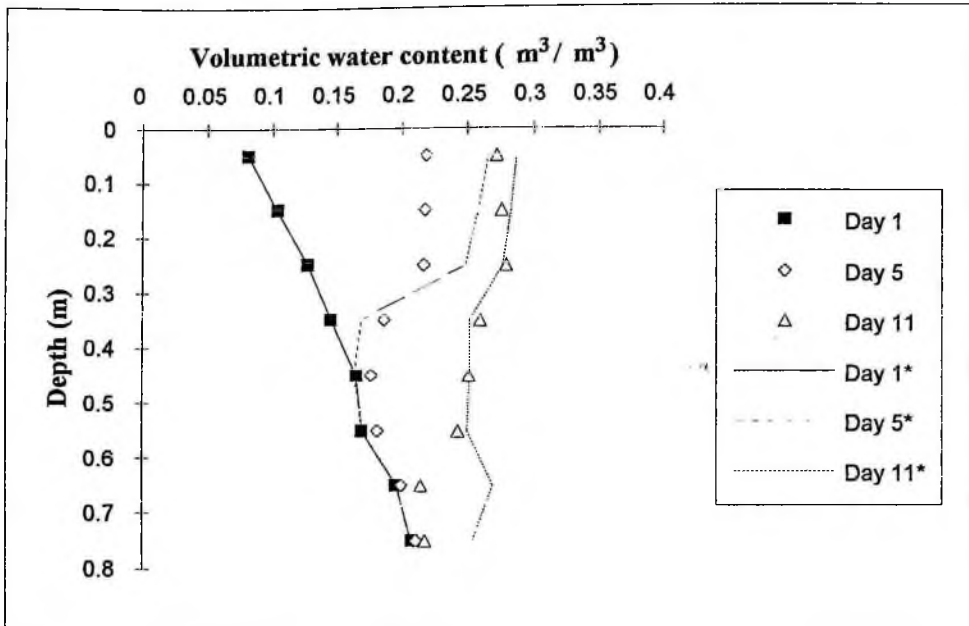

Fig. 5.2 Simulation of water movement under "Low Frequency Irrigation" (T1) Symbols and lines represent observed and simulated profiles, respectively

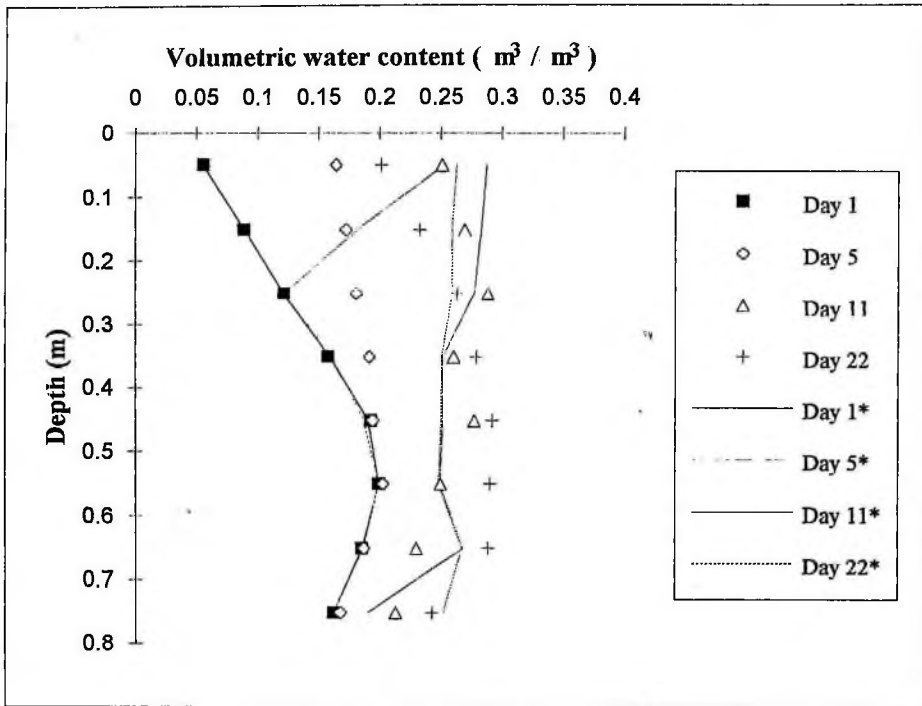

Fig. 5.3 Simulation of water movement under "Medium Irrigation Frequency" (T2 Symbols and lines represent observed and simulated profiles, respectively).

Like the first two treatments (T1 and T2), the top 0.3 m layers of plots under T3 almost always had lower measured moisture contents than the predicted values (Fig 5.4). In the first week, the model predictions were only good at depths 0.2-0.8 m and 0.3-0.8 m on days 5 and 7, respectively. Both the predicted and measured values showed that there had been little water movement into the lower 0.5 m during the first week. On days 15 and 22, the predicted values fairly agreed with the measured values throughout the profile.

To assess the accuracy of the model in predicting the moisture contents under the various irrigation treatments, 1:1 lines showing the theoretical relationship between the predicted and observed values were drawn and are presented in Figs. 5.5-5.7. Regression lines, correlation coefficients and, hence, the coefficients of determination for the treatment were computed and are also presented in Figs. 5.5-5.7. The correlations between observed and predicted values in all treatments were positive. In general, the predictions were best for T1 followed by T3 and then T2. With frequent irrigations, the effect of hysteresis and evaporation might have been pronounced to offset the efficacy of the model. The R^2 value of T3 is greater than that of T2 because as was seen in Figs. 5.3 and 5.4, the model performed better in simulating the water contents in the lower 0.5 m in T3 than in T2 at most times. The least R^2 value of T2 resulted from more deviation of the data points from the 1:1 line than those of T1 and T3. In T1 and T3 the model over-predicted the values of water content in the ranges 0.18-0.26 and 0.18-0.25 cm^3/cm^3 , respectively.

In all the treatments, the perfect agreement between observed and predicted moisture contents on day 1 was because the measured pre-irrigation water contents were used in the model as an initial condition and hysteresis was not influential. The over-prediction of moisture values

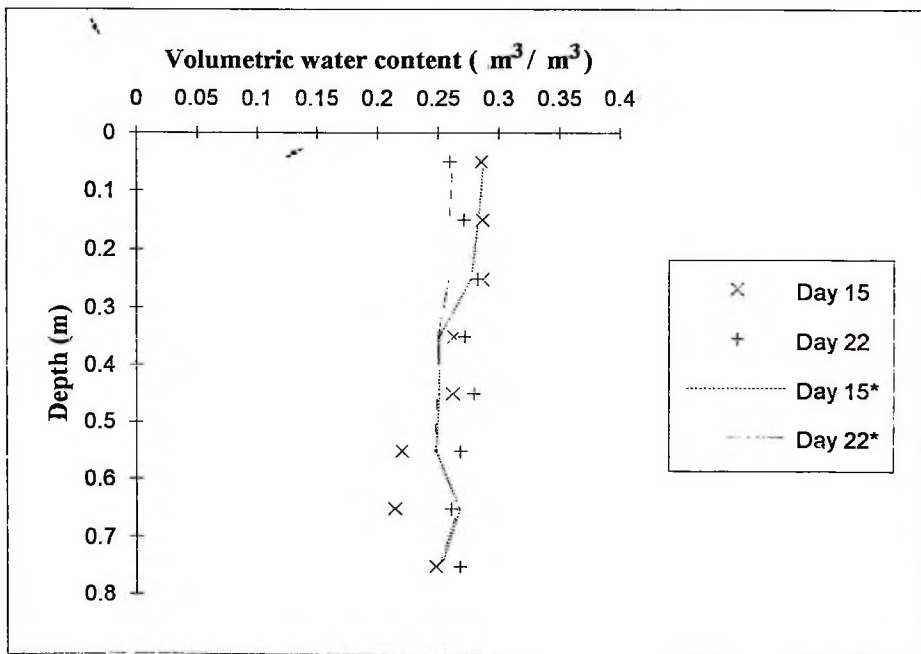
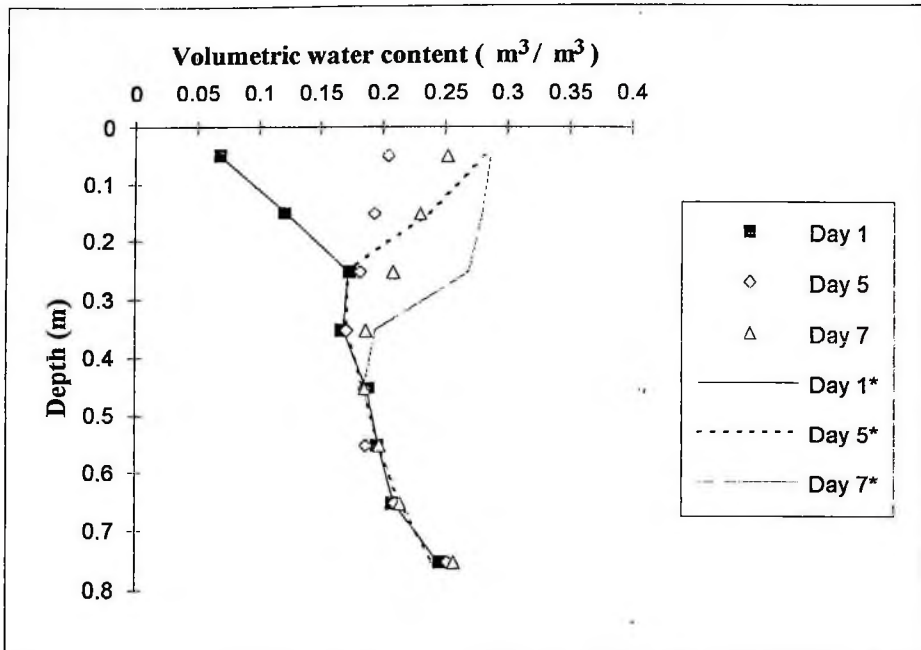

Fig. 5.4 Simulation of water movement under "High Frequency Irrigation" (T3). Symbols and lines represent observed and simulated profiles, respectively.

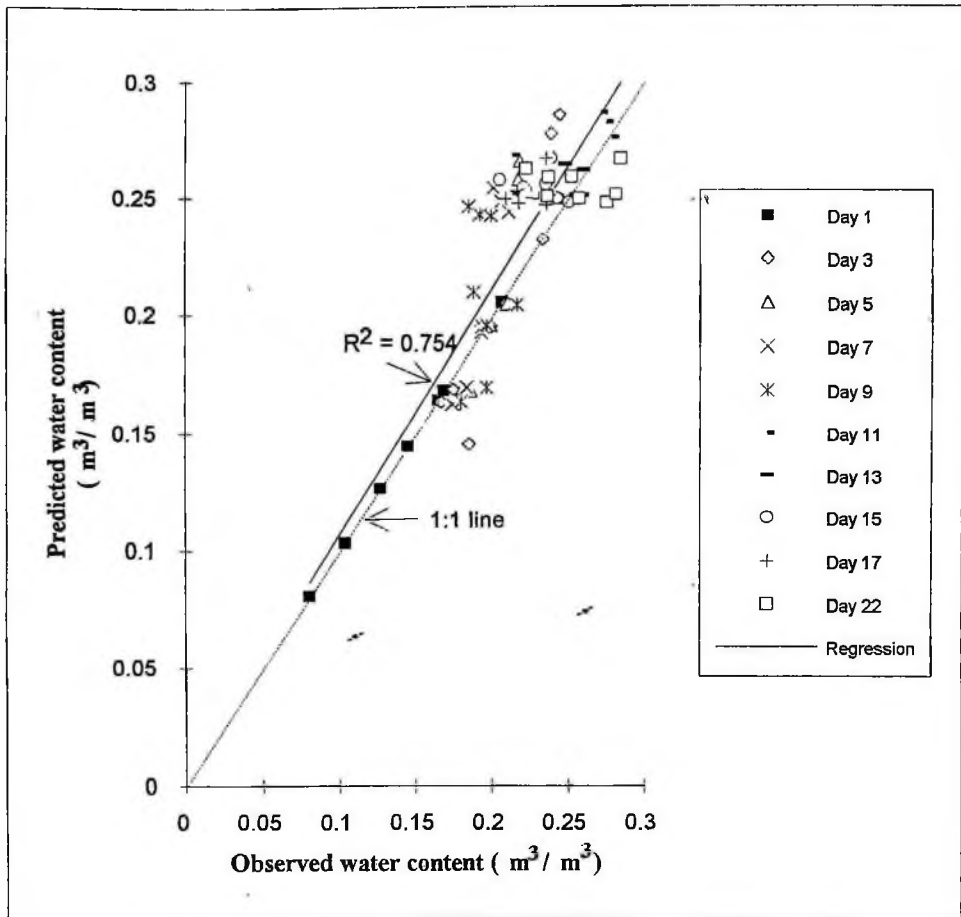

Fig. 5.5 Relationship between the observed and predicted water contents under T1

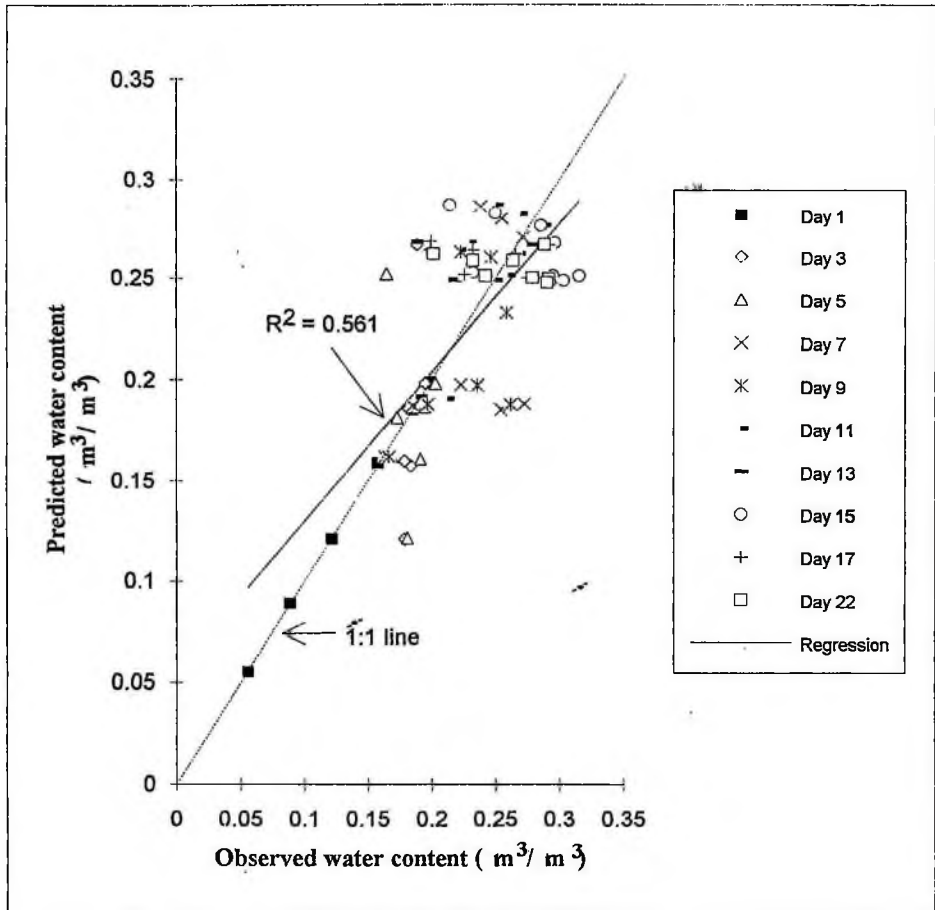

Fig. 5.6 Relationship between the observed and predicted water contents under T2

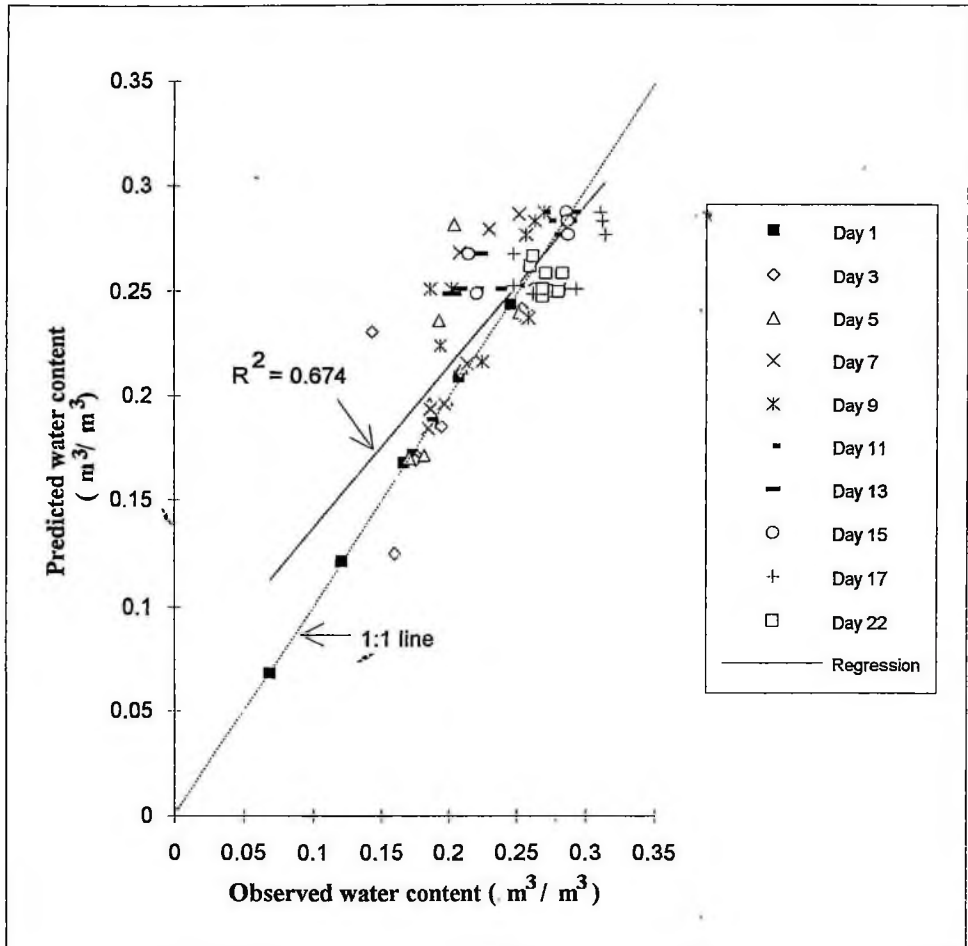

Fig. 5.7 Relationship between the observed and predicted water contents under T3

in the top layers (apart from day 1) may be due to the fact that evaporation was assumed to be negligible. The model, therefore, did not account for evaporation. Hence, in T3 where water was applied in small frequent increments, the soil surface was wet most of the time and losses through evaporation might have been highest compared with the other treatments (Hillel, 1980). This is evidenced by the fact that the deviations of the predicted moisture content values from the observed values in the top layers decreased in the order T3 > T2 > T1 (See Figs 5.2-5.4). Variabilities in soil physical properties may have contributed further to the deviations.

Other sources of error may emanate from the use of the neutron probe especially in the top layers where neutron escape may be prominent. Also the model assumed uniformity within a given layer with no regard to macroporosity or pore discontinuity. But in such a field soil, flow through macropores is likely. However, the model did not account for this. Furthermore, the estimation of the Campbell's parameter, b , from texture and other soil properties rather than from actual measurement of the soil moisture characteristic data can be a major source of model prediction errors.

Finally, water flow in soils may be influenced by hysteresis, especially under intermittent irrigation applications like this study. Indeed the influence of hysteresis on water transport has been reported by some researchers (Miller and Klute, 1967; Rubin, 1967; Curtis and Watson, 1984; Jones and Watson, 1987; and Russo et al., 1989). For example, Miller and Klute (1967) modified the general water flow equation (5.5) to account for hysteresis during redistribution to obtain:

$$\left(\frac{d\theta}{dh} \right)_h = \frac{\partial}{\partial z} \left[K_h(h) \frac{\partial h}{\partial z} \right] - \frac{\partial K_h(h)}{\partial z} \quad 5.10$$

where θ = volumetric water content (m^3/m^3), t = time (s), z = depth (m), h = matric potential (m) and the subscript h indicates a hysteretic function.

The consideration of hysteresis process in water flow equations can result in a more complex situation too difficult to be analysed quantitatively (Jury *et al.*, 1991). Thus, the effect of hysteresis was not considered in the model and this could have been a further contributory factor to the deviations between the predicted and the observed values in all the treatments, especially in the latter stages of the experiment.

5.3.2 Prediction of atrazine front within the soil profile

In the simulations of the solute movement, the K_d value for each 0.1-m layer was not available. Thus, comparison of absolute values of the predicted and observed concentrations in various layers was not made. However, the simulated and measured depths of leaching of atrazine under the various treatments were compared and are presented in Table 5.2.

In all treatments, the predicted rate of atrazine movement on day 2 was slower than the measured. Within the first week of application the model predicted shallower atrazine penetration and this may be attributed to solute flow through preferred pathways especially through macropores, such as cracks and worm-holes. On the subsequent two sampling days (days 15 and 22), however, there was a close agreement between the simulated and the measured depths of leaching. A comparison of the predicted and the observed values in all the treatments using χ^2 (Chi-squared) procedure indicated no significance difference between the observed and the predicted depths of leaching (see Table 5.2).

In the simulations, possible losses through volatilization and degradation were not accounted for. In spite of the fact that there were similar patterns in the depths of leaching on days 15 and 22, the predicted concentrations (data not shown) in the lower layers were negligible compared with the measured. This may also be attributed to preferential solute flow through macropores which was also not considered in the model.

Table 5.2 Comparison of predicted and measured depths (m) of leaching of atrazine on various days of sampling.

Days	Treatment 1		Treatment 2		Treatment 3	
	Observed	Predicted	Observed	Predicted	Observed	Predicted
2	0.45*	0.25	0.45	0.15	0.25	0.15
7	0.55	0.55	0.55	0.35	0.45	0.35
15	0.75	0.75	0.75	0.75	0.75	0.75
22	0.75	0.75	0.75	0.75	0.75	0.75

* Values represent midpoint of the layer of 0.1 m thickness.

$$\chi^2_{0.05,6} = 0.97 \text{ (ns)} < \chi^2_{\text{crit}} (12.592)$$

In conclusion, the model's performance in predicting water distribution was fairly good. The patterns of predicted soil moisture profiles were similar to those of the observed at most times. The performance of the model on solute transport, however, was generally poor although the patterns

of the solute fronts were quite similar. This is because losses through volatilization and degradation may be very high under field conditions but these were not accounted for in the model. Also due to unavailability of the sorption coefficients for all depths, the assumed values for the lower depths might have been high, resulting in underestimation of solute movement.

From the foregoing, it may be necessary to consider water transport through both micro- and macropores (which are normally encountered in field soils under minimum tillage) for improvement in the prediction of water movement. For the solute transport, volatilization and degradation losses must be estimated. Also, sorption characteristics of each layer of the soil profile must be thoroughly estimated.

CHAPTER 6

CONCLUSIONS AND RECOMMENDATIONS

To adopt an irrigation practice that minimises leaching of solutes from the soil profile, and hence minimise pollution of ground waters, T2 and T3 might be the most appropriate irrigation practices at the site. However, T2 may be preferred since it stores more water and leaches less atrazine.

The performance of the model in predicting water distribution was fairly good. The patterns of predicted soil moisture profiles were similar to those of the observed at most times. The performance of the model on solute transport, however, was generally poor although the patterns of the observed and predicted solute fronts were quite similar.

For a detailed study on water and solute movement in the soil, a complete sorption characteristics of each soil layer is needed. Evaporation studies may also be essential. Furthermore, it may be necessary to consider water transport through both micro- and macropores (which are normally encountered in coarse textured soils, shrinking soils with big cracks and in field soils under minimum tillage) for improvement in the prediction of water movement. For the solute transport, volatilization and degradation losses must be estimated.

It may be worthwhile to undertake similar work on water and solute movement in other Ghanaian soils, and under rainfed and cropped conditions. This will reflect the conditions in the tropics where most farmers practise rainfed agriculture.

CHAPTER 7**SUMMARY**

In this study, the movements of water and atrazine in a Ghanaian field soil were studied under three different irrigation frequencies. Dissipation and sorption of atrazine under the various treatments were also estimated. Furthermore, an attempt was made to model water movement and leaching fronts of the herbicide under the different irrigation frequencies. A total of 150 mm of water was applied in each treatment. In the first treatment (T1), 3 equal incremental water applications were done. In the second (T2) and third (T3) treatments, 5 and 9 equal incremental water applications were done, respectively.

Generally, the differences in irrigation treatments were reflected in the variation of water content profiles. The variations were more pronounced in T3 than in the others. Treatments 1 and 2 caused more downward water movement than T3. The soil water storage values under the treatments generally increased as the irrigation depth per event increased. However, storage under T2 was not intermediate. Treatment 2 had the highest storage and lowest water loss most times of the experiment. Consequently, it may have been intermediate in losses through evaporation (which was probably highest in T3) and deep percolation (which was probably highest in T1).

Atrazine concentrations in the top 0.1 m layer under all the treatments decreased with time, the rates of decrease being rapid in the first 15 days. All the treatments resulted in atrazine leaching, and the centres of mass at the end of the experiment were in the order $T1 > T2 \approx T3$. Since solute transport is caused primarily by water movement, this may be an indication that T1 resulted in

highest deep percolation.

The dissipation of atrazine increased with time resulting in decreasing recovery rate which was linear and significant. At the end of the experiment, the per cent atrazine dissipated was in the order $T1 > T3 > T2$ and the reverse was true for atrazine recovery.

Finally, a model based on mass flow was developed to simulate movement of water and atrazine in the field soil under the treatments. Field soil water content and solute front were compared with simulated water movement and simulated solute front, respectively. The simulated water profiles compared favourably with the field-measured in T1 and T3. In all treatments, the predicted water contents were higher in the top 0.3 m than the observed. Although the model also fairly well predicted the leaching fronts, the degree of agreement between observed and predicted atrazine concentrations was far lower than in the case of water predictions. The current limitations of the model and the improvement possibilities have been discussed.

REFERENCES

- Acquaye D.K. and K.B. Laryea. 1982. Unpublished soils report of the University of Ghana Farm, Legon. Dept. of Soil Science, University of Ghana.
- Adams, C.D. and E.M. Thurman. 1991. Formation and transport of deethylatrazine in the zone. *J. Environ. Qual.* 20: 540-547.
- Ahenkorah, Y., J.K. Amatekpor, G.N.N. Dowuona and S. Duah-Yentumi. 1994. A field survey report on soil and water resources of Ghana: Their conservation, management and constraints to their utilization for sustainable development. United Nations University Institute for Natural Resources in Africa Report. November, 1994. 131 pp.
- Ahuja, L.R., and R. Lehman. 1983. The extent and nature of rainfall-soil interaction in the release of soluble chemicals to runoff. *J. Environ. Qual.* 12: 34-40.
- Akobundu, I.O. 1987. Weed science in the tropics. Principles and practices. John Wiley and Sons. Chischester.
- Aldrich, R.J. 1984. Weed-crop ecology. Principles in weed management. Breton Pub. North Scituate, Massachusetts.
- Allmaras, R.R., R.E. Burwell, and R.R. Holt. 1967. Plow-layer and surface roughness from tillage as influenced by initial porosity and soil moisture of tillage time. *Soil Sci. Soc. Am. Proc.* 31: 550-556.
- Alva, A.K., G.J. Gascho and W.A. Cromer. 1990. Irrigation frequency effect on leaching of cations from gypsum amended coastal plain surface soils. *Water Air and Soil Pollution* 52: 325-336.
- Armstrong, D.E. and G. Chesters. 1968. Adsorption catalyzed chemical hydrolysis of atrazine. *Environ. Sci. Tech.* 2: 683-689.
- Armstrong, D.E., G. Chesters and R.F. Harris. 1967. Atrazine hydrolysis in soil. *Soil Sci. Soc. Am. Proc.* 31: 61-66.
- Ashraf, M.S., and D.K. Borah. 1992. Modelling pollutant transport in runoff and sediment. *Trans. A.S.A.E.* 35: 1789-1797.
- Ashton, F.M., and T.J. Sheets. 1959. The relationship of soil adsorption of EPTC to oats injury in various soil types. *Weeds* 7: 88-90.

- Bailey, G.W., R.R. Swank, Jr., and H.P. Nicholson. 1974. Predicting pesticide runoff from agricultural land: A conceptual model. *J. Environ. Qual.* 3: 95-102.
- Bailey, G.W., J.L. White, and T. Rothberg. 1968. Adsorption of organic herbicides by montmorillonite: role of pH and chemical character of adsorbate. *Soil Sci. Soc. Am. Proc.* 32: 222-234.
- Banks, P.A. and E.L. Robinson. 1982. The influence of straw mulch on the soil reception and persistence of metribuzin. *Weed Sci.* 30: 164-168.
- Banks, P.A. and E.L. Robinson. 1984. The fate of oryzalin applied to straw-mulched and nonmulched soils. *Weed Sci.* 32: 269-272.
- Best, J.A. and J.B. Weber. 1979. Disappearance of s-triazines as affected by soil pH using a balance sheet approach. *Weed Sci.* 22: 364-373.
- Beyer, E.M., H.M. Brown and M.J. Duffy. 1987. *Proc. Br. Crop Prot. Conf., Weeds.* p 531.
- Blake, G.R. and K.H. Hartge. 1986. Bulk density. pp 363-375. In Klute, A. (Ed.). 1986. *Methods of soil analysis. Part 1 (2nd edition) Physical and Mineralogical Methods-Agronomy Monograph no. 9*
- Boddy, P.L. and J.L. Baker. 1990. Conservation tillage effects on nitrate and atrazine leaching. Paper No. 902503. In: *Proc. of the Winter meeting of the ASAE. Chicago, IL. 21 Dec. 1990. ASAE, St. Joseph, MI.*
- Bouwer, H. 1986. Intake rate: Cylinder infiltrometer. pp 825-844. In Klute, A. (Ed.). 1986. *Methods of soil analysis. Part 1 (2nd edition) Physical and Mineralogical Methods-Agronomy Monograph no. 9*
- Bouyoucos, G.J. 1962. Hydrometer method improved for making particle size analysis of soils. *Agron. J.* 54:464-465.
- Brady, N.C. 1990. *The nature and properties of soils.* 10th edition. Macmillan Publishing Company. N.Y. 621 pp.
- Brammer, H. 1962. *Soils of Ghana.* pp 88-126. In Wills, J.B. (ed.). *Agriculture and land use in Ghana.* Oxford Univ. Press, New York.
- Brian R.C. 1976. The history and classification of herbicides. In Audus, L.J. (ed.) *Herbicides. Physiology, biochemistry, ecology.* (2nd edition) Vol. 1. pp 1-54. Academic Press, London.

- Briggs, G.G. 1981. Adsorption of pesticides by some Australian soils. *Aust. J. Soil Res.* 19: 61-68.
- Briggs, G.G. 1969. Molecular structure of herbicides and their sorption by soils. *Nature* 223: 1288-1289.
- Briska, A., J. Cencelj, J. Hocevar, J. Macek, and V. Sisakovic. 1973. Research on soil contamination by herbicides. *Agrohemiya* 1: 37-43. (Weed Abstracts, No. 1391, 1974).
- Brouwer, W.W.M., J.J.T.I. Boesten, and W.G. Siegers. 1990. Adsorption and transformation products of atrazine by soil. *Weed Res.* 30: 123-128.
- Brown, C.B. and J.L. White. 1969. Reactions of 12 s-triazines with soil clays. *Soil Sci. Soc. Am. Proc.* 33: 863-867.
- Brynes, B.H. 1990. Environmental effects of N fertilizer use - An overview. *Fertilizer Research* 26: 209-215.
- Burns, R.G., M.H.B. Hayes, and M. Stacey. 1973. Some physico-chemical interactions of paraquat with soil organic materials and model compounds. II. Adsorption and desorption equilibria in aqueous suspensions. *Weed Res.* 13: 79-90.
- Burns, I.G. 1974. A model for predicting the redistribution of salts applied to fallow soils after excess rainfall or evaporation. *J. Soil Sci.* 25: 165-178
- Burwell, R.E., R.R. Allmaras, and L.L. Sloneker. 1966. Structural alterations of soil surface by tillage and rainfall. *J. Soil Water Conserv.* 21:61-63.
- Calvet, R., and M. Terce. 1975. Adsorption de l'atrazine par les montmorillonites-Al. *Ann. Agron.* 26: 693-707.
- Calvet, R. 1980. Adsorption-desorption phenomenon. pp 1-30. In Hance, R.J. 1980. *Interactions between herbicides and the soil.* Academic Press, London.
- Campbell, G.S. 1974. A simple method for determining unsaturated conductivity from moisture retention data. *Soil Sci.* 117: 311-314.
- Carsel, R.F., C.N. Smith, L.A. Mulkey, J.D. Dean and P. Jowise. 1984. User's manual for the Pesticide Root Zone Model (PRZM) USEPA Rep. 600/3-84-109. USEPA, Athens, GA.
- Cassel, D.K. 1971. Water and solute movement in Svea loam for two water management regimes. *Soil Sci. Soc. Am. Proc.* 35: 859-866.

- Clay, S.A., K.A. Scholes, and D.E. Clay. 1994. Fertilizer shank placement impact on atrazine movement in a ridge tillage system. *Weed Sci.* 42: 86-91.
- Clay, S.A. and W.C. Koskinen. 1990. Adsorption and desorption of atrazine, hydroxyatrazine and s-glutathione atrazine on two soils. *Weed Sci.* 38: 262-266.
- Crosby, D.G. 1976. Nonbiological degradation of herbicides in the soil. pp 65-97. In: Audus, L.J. (ed.) *Herbicides: physiology, biochemistry, ecology*. 2nd edition. Vol. 2. Academic Press, London.
- Curtis, A.A. and K.K. Watson. 1984. Hysteresis-affected water movement in scale-heterogeneous profiles. *Water Resour. Res.* 20: 719-726.
- Czapar, G.F., R. Horton and R.S. Fawcett. 1992. Herbicide and tracer movement in soil columns containing an artificial macropore. *J. Environ. Qual.* 21: 110-115.
- Dao, T.H., T.L. Lavy, and R.C. Sorensen. 1979. Atrazine degradation and residue distribution in soil. *Soil Sci. Soc. Am. J.* 43: 1129-1134.
- Davidson, J.M. and J.R. McDougal. 1973. Experimental and predicted movement of 3 herbicides in a water-saturated soil. *J. Environ. Qual.* 2: 428-433.
- Davidson, J.M. and R.K. Chang. 1972. Transport of picloram in relation to soil physical conditions and pore-water velocity. *Soil Sci. Soc. Am. Proc.* 36: 257-261.
- Dick, W.A., R.J. Roseberg, E.L. McCoy, W.M. Edwards and F. Haghiri. 1989. Surface hydrologic response of soils to no-tillage. *Soil Sci. Soc. Am. J.* 53: 1520-1526.
- Doorenbos, J. and A.H. Kassam. 1979. *Yield response to water*. FAO Irrigation and Drainage paper 33. Rome.
- Dunigan, E.P. and McIntosh, Th. 1971. Atrazine-soil organic matter interaction. *Weed Sci.* 19: 279-282.
- Edwards, W.M., M.J. Shipitalo, W.A. Dick, and L.B. Owens. 1992. Rainfall intensity affects transport of water and chemicals through macropores in no-till soil. *Soil Sci. Soc. Am. J.* 56: 52-58.
- Fang, S.C., P. Thiesen, and V.H. Freed. 1961. Effect of water evaporation, temperature and rates of application on the retention of Ethyl-N,N-di-n-propylthiocarbamate in various soils. *Weeds* 9: 569-574.

- Farmer, W.J. and Y. Aochi. 1974. Picloram sorption in soils. *Soil Sci. Soc. Am. Proc.* 38: 418-423.
- Ferguson, R.B., C.A. Shapiro, G.W. Hergert, W.L. Kranz, N.L. Klocke, and D.H. Krull. 1991. Nitrogen and irrigation management practices to minimize nitrate leaching from irrigated corn. *J. Prod. Agric.* 4: 186-192.
- Focht, D.D. and H. Joseph. 1973. An improved method for the enumeration of denitrifying bacteria. *Soil Sci. Soc. Am. Proc.* 37: 698-699.
- Frere, M.H. 1975. Integrating chemical factors with water and sediment transport from a watershed. *J. Environ. Qual.* 4: 13-17.
- Frissel, J.M. and G.H. Bolt. 1962. Interaction between certain ionizable organic compounds (herbicides) and clay minerals. *Soil Sci.* 94: 284-291.
- Gerstl, Z. and U. Mingelgrin. 1979. A note on the adsorption of organic molecules on clays. *Clays Clay Miner.* 27: 285-290.
- Gerstl, Z. 1991. Behaviour of organic agrochemicals in soils. *Pesticide outlook* 2: 8-12.
- Ghadiri, H., P.J. Shea and G.A. Wicks. 1984. Interception and retention of atrazine by wheat (*Triticum aestivum* L.) stubble. *Weed Sci.* 32: 24-27.
- Ghodrati, M. 1989. The influence of water application method, pesticide formulation and surface preparation method on pesticide leaching. Ph.D. Thesis. University of California, Riverside.
- Gish, T.J., A.R. Isensee, R.G. Nash, and C.S. Helling. 1991a. Impact of pesticides on shallow groundwater quality. *Trans. A.S.A.E.* 34: 1745-1753.
- Gish, T.J., M.J. Schoppet, C.S. Helling, A. Shirmohammadi, M.M. Schreiber, and R.E. Wing. 1991b. Transport comparison of technical grade and starch-encapsulated atrazine. *Trans. A.S.A.E.* 34: 1738-1744.
- Gish, T.J., A. Shirmohammadi, R. Vyravipillai, and B.J. Wienhold. 1995. Herbicide leaching under tilled and no-tillage fields. *Soil Sci. Soc. Am. J.* 59: 895-901.
- Glotfelty, D.E., and C.J. Schomburg. 1989. Volatilization of pesticides from soil. pp. 181-207. In Sawhney, B.L., and K. Brown (ed.) *Reaction and movement of organic chemicals in soils.* SSSA Spec. Publ. 22, ASA & SSA, Madison, WI.

- Goetz, A.J., R.H. Walker, G. Wehtje, and B.F. Hajek. 1988. Sorption and mobility of chlorimuron in Alabama soils. *Weed Sci.* 37: 428-433.
- Graber, E.R., Z. Gerstl, E. Fischer, and U. Mingelgrin. 1995. Enhanced transport of atrazine under irrigation with effluent. *Soil Sci. Soc. Am. J.* 59: 1513-1519.
- Green, R.E., R.C. Schneider, R.T. Gavenda and C.J. Miles. 1993). Utility of sorption and degradation parameters from literature for site-specific pesticide impact assessments. P 205-225. *In* Linn D.M. et al (ed.). Sorption and degradation of pesticides and organic chemicals in soil. *Soil Sci. Soc. Am. Special Pub. No. 32.*
- Green, J.D., R. Horton, and J.K. Baker. 1995. Crop residue effects on the leaching of surface-applied chemicals. *J. Environ. Qual.* 24: 343-351
- Greenwood, D.J. and A. Walker. 1990. Modelling soil productivity and pollution. *Phil. Trans. R. Soc. Lond. B.* 329: 309-320.
- Grover, R. 1975. Adsorption and desorption of urea herbicides on soils. *Can. J. Soil Sci.* 55: 127-136.
- Guenzi, W.D. and W.E. Beard. 1970. Volatilization of Lindane and DDT from soils. *Soil Sci. Soc. Am. Proc.* 34: 443-447.
- Guenzi, W.D. and W.E. Beard. 1967. Movement and persistence of D.D.T. and Lindane in soil columns. *Soil Sci. Soc. Am. Proc.* 31: 664-674.
- Guenzi, W.D. and W.E. Beard. 1976. Picloram degradation in soils as influenced by soil water content and temperature. *J. Environ. Qual.* 5: 189-192.
- Haith, D.A. 1980. A mathematical model for estimating pesticide losses in runoff. *J. Environ. Qual.* 9: 429-433.
- Hall, J.K., M.R. Murray and N.L. Hartwig. 1989. Herbicide leaching and distribution in tilled and untilled soil. *J. Environ. Qual.* 18: 439-445.
- Hamaker, J.W., C.A.I. Goring and C.R. Youngson. 1966. *Advan. Chem. Ser.*, 66: 23-27.
- Hamaker, J.W., and J.M. Thompson. 1972. Adsorption. pp 49-143. *In*: Goring, C.A.I., and J.W. Hamaker (eds.). *Organic chemicals in the soil environment.* Marcel-Dekker, New York.
- Hamaker, J.W. 1972. Decomposition: quantitative aspects. pp 253-340. *In*: Goring, C.A.I., and J.W. Hamaker (eds.). *Organic chemicals in the soil environment.* Marcel-Dekker, New York.

- Hamlett, J.M., J.L. Baker and R. Horton. 1990. Water and anions movement ridge tillage: A field study. *Trans. A.S.A.E.* 36: 1859-1866.
- Hance, R.J. 1965. The adsorption of urea and some of its derivatives by a variety of soils. *Weed Res.* 5: 108-114.
- Hance, R.J. 1969a. Influence of pH, exchangeable cations and the presence of organic matter on the adsorption of some herbicides by montmorillonite. *Can. J. Soil Sci.* 49: 357-364.
- Hance, R.J. 1969b. Further observations of the decomposition of herbicides in soil. *J. Sci. Food Agric.* 20: 144-145.
- Hance, R.J. 1977. The adsorption of atraton and monuron by soils at different water contents. *Weed Res.* 17: 197-201.
- Hance, R.J. 1979. Effect of pH on the degradation of atrazine, dichlorprop, linuron, and propyzamide in soil. *Pest. Sci.* 10: 83-86.
- Hance, R.J. 1980. Transport in the vapour phase. pp. 59-81. In: Hance R.J. (ed.) *Interactions between herbicides and the soil.* Academic Press, London.
- Harper, S.S. 1988. Sorption of metribuzin in surface and subsurface soils of the Mississippi Delta region. *Weed Sci.* 36: 84-89.
- Harris, C.I., E.A. Woolson, and B.E. Hummer. 1969. Dissipation of herbicides at 3 soil depths. *Weed Sci.* 17: 27-31.
- Harris, C.I. and G.F. Warren. 1964. Adsorption and desorption of herbicides by soil. *Weeds* 12: 120-126.
- Hassal, K.A. 1990. *The biochemistry and uses of pesticides.* 2nd Edition. Macmillan Press Ltd., Hampshire. UK.
- Helling, C.S., W. Zhuang, T.J. Gish, C.B. Coffman, A.R. Isensee, P.C. Kearney, D.R. Hoagland, and M.D. Woodward. 1988. Persistence and leaching of atrazine, alachlor, and cyanazine under no-tillage practices. *Chemosphere* 17: 175-187.
- Hillel, D. 1980. *Introduction to Soil Physics.* Academic Press, Inc. New York.
- Hilton, H.V., and Q.H. Yuen. 1963. Adsorption of several pre-emergence herbicides by Hawaiian sugar cane soils. *J. Agric. Food Chem.* 11: 230-234.
- Hurle, K., and A. Walker. 1980. Persistence and its prediction. pp 83-122. In: Hance, R.J. (ed.) *Interactions between herbicides and the soil.* Academic Press, London.

- Ingram J.J. and D.A. Woolhiser. 1980. Chemical transfer into overland flow. In: Proc. Symp. Watershed Management, 40-53. Boise, ID, 21-33 July. New York. American Society of Civil Engineers.
- Isensee, A.R., R.G. Nash, and C.S. Helling. 1990. Effect of conventional vs no-tillage on pesticide leaching to shallow groundwater. *J. Environ. Qual.* 19: 434-440.
- Isensee, A.R., and A.M. Sadeghi. 1994. Effects of tillage and rainfall on atrazine residue levels in soils. *Weed Sci.* 42: 462-467.
- Jackson, M.L. 1962. *Soil Chemical Analysis*. Constable and Co. Ltd. London. 498 p.
- Jardine, P.M., G.V. Wilson, R.J. Luxmoore and J.F. McCarthy. 1989. Transport of inorganic and natural organic tracers through an isolated pedon in a forest watershed. *Soil Sci. Soc. Am. J.* 53: 317-323.
- Johnson, R.M. and J.J. Furhmann. 1993. Degradation of atrazine and metolachlor in subsoils from an Atlantic Coastal Plain Watershed. pp 27-31. In: Linn D.M., T.H. Carski, M.L. Brusseau, and F.H. Chang (eds.). *Sorption and degradation of pesticides and organic chemicals in soil*. SSSA Spec. Publ. no. 32.
- Jones, M.J. and K.K. Watson. 1987. Effect of soil water hysteresis on solute movement during intermittent leaching. *Water Resour. Res.* 23: 1251-1256.
- Jones, R.E., Jr., P.A. Banks and D.E. Radcliffe. 1990. Alachlor and metribuzin movement and dissipation in a soil profile as influenced by soil surface conditions. *Weed Sci.* 38: 589-597.
- Jordan, L.S., B.E. Day and W.A. Clerx. 1963. Photodecomposition of triazine. *Weeds* 12(3): 5-6.
- Jury, W.A, W.R. Gardner and W.H. Gardner. 1991. *Soil Physics*. 5th Edition. John Wiley and Sons, Inc. N.Y. p. 128.
- Jury, W.A. and H. Fluhler. 1992. Transport of chemicals through soil: Mechanisms, models, and field applications. *Adv. Agron.* 47: 141-201.
- Kanwar, R.S. 1991. Preferential movement of nitrate and herbicides to shallow groundwater as affected by tillage and crop rotation. In *Proceedings: preferential flow*. T.J. Gish and A. Shirmohammadi (ed.) Chicago, IL. pp.328-337.
- Kearney P.C., P.J. Sheets, and J.W. Smith. 1964. Volatility of seven s-triazines. *Weeds* 12: 83-87.

- Kemper, W.D., J. Olsen, and A. Hodgdon. 1975. Fertilizer or salt leaching as affected by surface shaping and placement of fertilizer and irrigation water. *Soil Sci. Soc. Am. Proc.* 39: 115-119.
- Khan, S.U. 1980. *Pesticides in the soil environment*. Elsevier Scientific Publishing Co. N.Y.
- Khan, S.U., P.B. Marriage, and A.S. Hamill. 1981. Effects of atrazine treatment of a corn field using different application methods, times, and additives on the persistence of residues in soil and their uptake by oat plants. *J. Agric. Food Chem.* 29: 216-219.
- Kissel, D.E., M.L. Cabrera, and R.B. Ferguson. 1988. Reactions of ammonia and urea hydrolysis products with soils. *Soil Sci. Soc. Am. J.* 52: 1793-1796.
- Klute, A. and C. Dirksen. 1986. Hydraulic conductivity and diffusivity: laboratory methods. pp 687-734. In Klute, A. (ed.) 1986. *Methods of soil analysis. Part 1 (2nd edition) Physical and Mineralogical Methods-Agronomy Monograph no. 9*
- Knusli, E., H.P. Burchfield and E.E. Storrs. 1969. Analytical methods for pesticide, plant growth regulators and food additives. Vol. IV. Herbicides. (G. Zweig, ed.) pp 33-36, 213-233.
- Koorevaar, P., G. Menelik and C. Dirksen. 1983. *Elements of Soil Physics. Developments in Soil Science 13*. Elsevier Sci. Pub., Amsterdam. 228 pp.
- Koskinen, W.C. and S.S. Harper. 1990. The retention process: Mechanism. In: Cheng, H.H. (ed.). *SSSA Book Series 2; Soil Sci. Soc. Am.; Madison, WI.* pp 51-78.
- Ladlie, J.S., W.F. Meggit, and D. Penner. 1976. Effect of soil pH on microbial degradation, adsorption and mobility of metribuzin. *Weed Sci.* 24: 477-481.
- Lavy, T.L. 1970. Diffusion of three chloro s-triazines in soil. *Weed Sci.* 18: 53-56.
- Leistra, M. 1980. Transport in solution. pp 31-58. In: Hance, R.J. (ed.) *Interactions between herbicides and the soil*. Academic Press, London.
- Letey, J. and W.J. Farmer. 1974. Movement of pesticides in soil. In: Guenzi, W.D. and (ed.). *Pesticide in soil and water*. pp 67-97. *Soil Sci. Soc. Am., Madison, WI.*
- Lindstrom, F.T., L. Boersma and H. Gardiner. 1968. 2,4-D diffusion in saturated soils: a mathematical theory. *Soil Sci.* 106: 107-113.
- Liu, Z., S.A. Clay, D.E. Clay, and S.S. Harper. 1995. Ammonia fertilizer influences atrazine adsorption-desorption characteristics. *J. Agric. Food Chem.* 43: 815-819.

- Liu, L.C., H. Cibes-Viade, and F.K.S. Koo. 1970. Adsorption of ametryne and diuron by soils. *Weed Sci.* 25: 401-406.
- Madhun, Y.A., V.H. Freed, and J.L. Young. 1986. Sorption of bromacil, chlortoluron and diuron by soils. *Soil Sci. Soc. Am. J.* 50: 1467-1471.
- Marshall, T.J. and J.W. Holmes. 1988. *Soil Physics*. Cambridge University Press. pp 193, 315.
- McGlamery, M. and F.W. Slife. 1966. The adsorption and desorption of atrazine as affected by pH, temperature and concentration. *Weeds* 14: 237-239.
- McLean, E.O. 1982. Soil pH and lime requirement. pp 199-224. In Page, A.L., R.H. Miller and D.R. Keeney (ed.) 1982. *Methods of soil analysis. Part 2 (2nd edition). Chemical and Microbiological Properties-Agronomy Monograph no. 9*
- Miller, R.J., J.W. Biggar and D.R. Nielsen. 1965. Chloride displacement in Panoche clay loam in relation to water movement and distribution. *Water Resources Research* 1:63-73.
- Miller, E.E. and A. Klute. 1967. Dynamics of soil water. Part 1 - Mechanical forces. *In Irrigation of Agricultural lands*. pp 209-244. Monograph 11, Am. Soc. Agron., Madison. WI.
- Ministry of Agriculture. 1991. *Maize and cowpea production guide*.
- Muszkat, L., L. Lahav, D. Ronen, and M. Magaritz. 1993. Penetration of pesticides and industrial organics deep into soil and into groundwater. *Arch. Insect Biochem. Physiol.* 22: 487-499.
- Nearpass, D.C. 1972. Hydrolysis of propazine by the surface acidity of organic matter. *Soil Sci. Soc. Am. Proc.* 36: 606-610.
- Nelson, D.W. and L.E. Sommers. 1982. Total Carbon, Organic Carbon and Organic Matter. pp 539-594. In Page, A.L., R.H. Miller and D.R. Keeney (ed.) 1982. *Methods of soil analysis. Part 2 (2nd edition). Chemical and Microbiological Properties-Agronomy Monograph no. 9*
- Nielsen, D.R., J.W. Biggar and R.J. Miller. 1967. Field observations of infiltration and soil-water redistribution. *Trans. A.S.A.E.* 10: 382-387, 410.
- Nielsen, D.R. and J.W. Biggar. 1962. Miscible displacement. III. Theoretical considerations. *Soil Sci. Soc. Am. Proc.* 26: 216-221.
- Nofziger, D.L. and A.G. Hornsby. 1986. A microcomputer-based management tool for chemical movement in soil. *Appl. Agric. Res.* 1: 50-56.

- Norman, R.J., L.T. Kurtz, and F.J. Stevenson. 1987. Solubilization of soil organic matter by liquid anhydrous ammonia. *Soil Sci. Soc. Am. J.* 51: 801-812.
- Oppong, F.K., and G.R. Sagar. 1992. The activity and mobility of triasulfuron in soil as influenced by organic matter, duration, amount and frequency of rain. *Weed Res.* 32: 157-165.
- Petach, M.C., R.J. Wagenet and S.D. DeGloria. 1991. Regional water flow and pesticide leaching using simulations with spatially distributed data. *Geoderma* 48: 245-269.
- Phene, C.J. and O.W. Beale. 1976. High-frequency irrigation for water nutrient management in humid regions. *Soil Sci. Soc. Am. Proc.* 40: 430-436.
- Pionke, H.B., D.E. Glotfelty, A.D. Lucas, and J.B. Urban. 1988. Pesticide contamination of groundwaters in the Manhantango Creek watershed. *J. Environ. Qual.* 17: 76-84.
- Rao, P.S.C., and R.E Jessup. 1983. Sorption and movement of pesticides and other toxic organic substances in soils. pp 183-201. In: Nelson D.W., D.E. Elrick, and K.K. Tanji (eds.). *Chemical mobility and reactivity in soil systems*. SSSA Spec. Publ. no. 11
- Rao, P.S.C., J.M. Davidson and L.C. Hammond. 1976. Estimation of non-reactive and reactive solute front locations in soils. p 235-242. *In Fuller, W.H. (ed.). Residue management by land disposal. Proc. Waste Research Symp., Univ. of Arizona, Tucson, AZ. Print Office, Washington D.C.*
- Rawlins, S.L. 1973. Principles of managing high frequency irrigation. *Soil Sci. Soc. Am. Proc.* 37: 626-629.
- Rawlins, S.L. and P.A.C. Raats. 1975. Prospects for high-frequency irrigation. *Science* 188: 604-610.
- Rose, C.W., F.W. Chichester, J.R. Williams and J.T. Ritchie. 1982. Application of an approximate analytic method of computing solute profiles with dispersion in soils. *J. Environ. Qual.* 11: 146-155.
- Rubin, J. 1967. Numerical method for analysing hysteresis-affected, post-infiltration redistribution of soil moisture. *Soil Sci. Soc. Am. Proc.* 31: 13-20.
- Russel, J.D., M. Guy, J.L. White, G.W. Bailey, W.R. Payne, J.O. Pope., and J.I. Teasley. 1968. Model of chemical degradation of triazines by montmorillonite. *Science* 160: 1340-1342.

- Russo, D., W.A. Jury and G.L. Butters. 1989. Numerical analysis of solute transport during transient irrigation. I. Effect of hysteresis and profile heterogeneity. *Water Resour. Res.* 25: 2109-2118.
- Saffigna, P.G., C.B. Tanner and D.R. Keeney. 1976. Non-uniform infiltration under potato canopies caused by interception, stemflow, and hilling. *Agron. J.* 68: 337-342.
- Sauer, T.J., and T.C. Daniel. 1987. Effect of tillage system on runoff losses of surface-applied pesticides. *Soil Sci. Soc. Am. J.* 51: 410-415.
- Savage, R.E. 1976. Adsorption and mobility of metribuzin in soil. *Weed Sci.* 24: 525-528.
- Savage, R.E. and R.D. Wauchope. 1974. Fluometuron adsorption-desorption equilibria in soil. *Weed Sci.* 22: 106-110.
- Schmidt, R.R. and W. Pestemer, 1980. Plant availability and uptake of herbicides from soil. In: Hance, R.J. (ed.). *Interactions between herbicides and the soil.* pp 179-201. Academic Press, London.
- Schreiber, M.M., B.S. Shasha, D. Trimmel and M.D. White. 1987. Controlled release herbicides. pp 171-191. In: McWhooter, C.G. and M. Gebhardt (eds.). *Methods of applying herbicides.* Weed Sci. Soc. Am. Monogr. Ser. WSSA, Champaign, IL.
- Scott, H.D. and R.E. Phillips. 1972. Diffusion of selected herbicides in soil. *Soil Sci. Soc. Am. Proc.* 36: 714-719.
- Scotter, D.R., R.E. White and J.S. Dyson. 1993. The Burns' leaching equation. *J. Soil Sci.* 44: 25-33.
- Scow, K.M. 1993. Effect of sorption-desorption and diffusion processes on the kinetics of biodegradation of organic chemicals in soil. pp 73-114. In: Linn D.M., T.H. Carski, M.L. Brusseau, and F.H. Chang (eds.). *Sorption and degradation of pesticides and organic chemicals in soil.* SSSA Spec. Publ. no. 32.
- Shepherd, M.A., D.B. Davies and P.A. Johnson. 1993. Minimising nitrate losses from arable soils. *Soil Use and Management* 9: 94-98.
- Shipitalo, M.J., W.M. Edwards, W.A. Dick, and L.B. Owens. 1990. Initial storm effects on macropore transport of surface-applied chemicals in no-tilled soil. *Soil Sci. Soc. Am. J.* 54: 1530-1536.

- Sigua, G.C., A.R. Isensee and A.M. Sadeghi. 1993. Influence of rainfall intensity and crop residue on leaching of Atrazine through intact no-till soil cores. *Soil Science* 156(4) : 225-233.
- Smith, A.E. 1982. Herbicides and the soil environment in Canada. *Can. J. Soil Science* 62: 433-460.
- Smith, A.E. and A. Walker. 1989. Prediction of the persistence of the triazine herbicides: atrazine, cyanazine and metribuzin in Regina heavy clay. *Can. J. Soil Sci.* 69: 587-595.
- Smith., D.T., and W.F. Meggit. 1970. Persistence and degradation of pyrazon in soil. *Weed Sci.* 18: 260-264.
- Soil survey staff. 1992. *Keys to Soil Taxonomy*. 5th. ed. Soil Management Support Serv. Tech. Monogr. 19. Pocahontas Press. Inc., Blacksburgh, VA.
- Spalding, R.F., M.E. Exner, J.J. Sullivan, and P.A. Lyon. 1979. Chemical seepage from a tail water recovery pit to adjacent groundwater. *J. Environ. Qual.* 8: 374-383.
- Spencer, W.F. and M.M. Cliath. 1974. Factors affecting vapour loss to trifluralin from soil. *J. Agric. Food Chem.* 22: 987-991.
- Spencer, W.F., W.J. Farmer and M.M. Cliath. 1973. Pesticide volatilization. *Residue Rev.* 49: 1-47.
- Starr, J.L. and D.E. Glotfelty. 1990. Atrazine and bromide movement through a silt loam soil. *J. Environ. Qual.* 19: 552-558.
- Stearman, G.K., R.J. Lewis, L.J. Tortorelli, and D.D. Taylor. 1989. Herbicide reactivity of soil organic matter in no-tilled and tilled cotton. *Soil Sci. Soc. Am. J.* 53: 1690-1694.
- Stevenson, F.J. 1972. Organic matter reactions involving herbicides in soil. *J. Environ. Qual.* 1: 333-343.
- Taylor, A.W. 1978. Post application volatilization of pesticides under field conditions. *J. Air Poll. Contr. Assoc.* 28: 922-927.
- Troiano, J., C. Garretson, C. Krauter, J. Brownell and J. Hutson. 1993. Influence of amount and method of irrigation water application on leaching of atrazine. *J. Environ. Qual.* 22:290-298.

- Vinten, A.J.A., B. Vivian and M.H. Redman. 1991. An analysis of the leaching of chloride tracer applied to pipe-drained plots using a coupled unsaturated-saturated zone model of solute transport. *Soil Use and Management* 7: 103-109.
- Wagenet, R.J. and J.L. Hutson. 1989. LEACHM Leaching Estimation and Chemistry Model. A process-based model of water and solute movements, transformations, plant uptake and chemical reactions in the unsaturated zone. *Continuum Vol. 2 (Version 2.0)*. Water Resources Institute, Center for Environmental Research, Cornell Univ.
- Wagenet, R.J. and P.S.C. Rao. 1990. Modelling pesticide fate in soils. pp 351-399. In: Cheng, H.H. (ed.). *Pesticides in the soil environment*. Soil Sci. Soc. Am. Book Series 2; Soil Sci. Soc. Am.; Madison, WI.
- Walker, A. and D.V. Crawford. 1970. Diffusion coefficients for 2 triazine herbicides in six soils. *Weed Res.* 10: 126-132.
- Walker, A., and J.A. Thompson. 1977. The degradation of simazine, linuron and propyzamide in different soils. *Weed Res.* 17: 399-405.
- Walker, A., G.G. Briggs, M.P. Greaves, R.J. Hance, and A.R. Thompson. 1982. Herbicides in soil. In Roberts, H.A. (ed.). *Weed control handbook, Principles*. 7th edition. Blackwell Scientific Publications, Oxford.
- Watts, D.G., G.W. Hergert and J.T. Nichols. 1991. Nitrogen leaching losses from irrigated orchardgrass on sandy soils. *J. Environ. Qual.* 20: 355-362.
- Wehtje, G., L.N. Mielke, J.R.C. Leavitt, and J.S. Schepers. 1984. Leaching of atrazine in the root zone of an alluvial soil in Nebraska. *J. Environ. Qual.* 13: 507-513.
- White, R.E., J.S. Dyson, Z. Gerstl, and B. Yaron. 1986. Leaching of herbicide through undisturbed cores of a structured clay soil. *Soil Sci. Soc. Am. J.* 50: 277-283.
- Wienhold, B.J. and T.J. Gish. 1994. Effect of formulation and tillage practice on volatilization of atrazine and alachlor. *J. Environ. Qual.* 23: 292-298.
- Wiese, A.F. and R.G. Davis. 1963. Herbicide movement in soil with various amounts of water. *Weeds* 12: 101-103.
- Yamauchi, H. 1984. Impact on groundwater resources on conversion from furrow to drip irrigation. *Water Resour. Bull.* 20: 557-563.

- Yaron, B. 1989. General principles of pesticide movement to groundwater. *Agric. Ecosystems Environ.* 26: 275-297.
- Yaron, B., Z. Gerstl and W.F. Spencer. 1985. Behaviour of herbicides in irrigated soils. In: Stewart, B.A. (ed.). *Advances in Soil Science.* pp 121-211.
- Yuen, Q.H. and H.W. Hilton. 1962. The adsorption of monuron and diuron in Hawaiian sugar cane soils. *J. Food Agric. Chem.* 10: 386-392.

APPENDIX A

```

*****
*   Program to monitor water and solute transport in field soils *
*   under Varying Irrigation Frequency                               *
*****
*   Declare variables

      Integer i,id, j, n, nlay, day, dac

      Real theta(16), laythick, psim(16), hydcon(16), psie(16),
+     thetas(16), Ks(16), be(16), flux(16), avhydcon(16),
+     hydpot(16), hydgrad(16), psiz(16), z, thetini, outflo,
+     inf, deltheta(16), dt, irrig, fluxs(16), conc(16),
+     delconc(16), retard(16), store(16), storefc8,
+     outflow(16), thetfc(16), bd(16), Kd(16)

*   CREATE FILES

*(a) Files for treatment T1:

      Open (unit=7, file='infile1.dat', access='sequential',
+ status= 'old')
      Open (unit=8, file='outfile1.prn', access='sequential',
+ status= 'unknown')

*(b) Files for treatment T2:

      Open (unit=7, file='infile2.dat', access='sequential',
+ status= 'old')
      Open (unit=8, file='outfile2.prn', access='sequential',
+ status= 'unknown')

*(c) Files for treatment T3:

      Open (unit=7, file='infile3.dat', access='sequential',
+ status= 'old')
      Open (unit=8, file='outfile3.prn', access='sequential',
+ status= 'unknown')

      write(8,*)'dac, layer, theta'

*   Initialise variables

      laythick = 5.0
      outflo=0
      inf=0
      dt=1
      area=10000 ! = 100 x 100 sq cm

      do 5 i=1,16

          if(i .eq. 1) then
              theta(i)=      ! cm3/cm3 (input the appropriate
* initial water content of the layer for the treatment (Table 5.1)

```

111

```

        thetas(i)=0.469      ! cm3/cm3
        thetfc(i) = 0.30     ! cm3/cm3
        bd(i)=1.39          ! g/cm3
        Kd(i)=1.93         ! cm3/g
        Ks(i)=65           ! cm/day
        be(i)=4.928        ! Campbells parameter
        psie(i)=-4.02      ! cm
        conc(i) =250000/(laythick*area*bd(i))

elseif (i .eq. 2) then
*
*
        theta(i)=          ! cm3/cm3 (input the appropriate
                           initial water content of the
                           layer for the treatment).

        thetas(i)=0.469    ! cm3/cm3
        thetfc(i) = 0.30   ! cm3/cm3
        bd(i)=1.39        ! g/cm3
        Kd(i)=1.93       ! cm3/g
        Ks(i)=65         ! cm/day
        be(i)=4.928      ! Campbells parameter
        psie(i)=-4.02    ! cm
        conc(i) = 0.0

elseif(i .gt. 2 .and. i .le. 4) then
*
*
        theta(i)=          ! cm3/cm3 (input the appropriate
                           initial water content of the
                           layer for the treatment).

        thetas(i)=0.42
        thetfc(i) = 0.31
        bd(i)= 1.52
        Kd(i)= 1.93
        Ks(i)=19.7
        be(i)=5.585
        psie(i)=-5.36
        conc(i) =0.0

elseif(i .gt. 4 .and. i .le. 6) then
*
*
        theta(i)=          ! cm3/cm3 (input the appropriate
                           initial water content of the
                           layer for the treatment).

        thetas(i)=0.406
        thetfc(i) = .30
        bd(i)= 1.56
        Kd(i)= 0.55
        Ks(i)=34.00
        be(i)=6.51
        psie(i)=-6.09
        conc(i)  0.0

elseif(i .gt. 6 .and. i .le. 8) then
*
*
        theta(i)=          ! cm3/cm3 (input the appropriate
                           initial water content of the
                           layer for the treatment).

        thetas(i)=0.427

```

```

        thetfc(i) = 0.25
        bd(i)= 1.51
        Kd(i)= 0.55
        Ks(i)=49.08
        be(i)=6.648
        psie(i)=-4.94
        conc(i) = 0.0

elseif(i .gt. 8 .and. i .le. 10) then
    theta(i)=          ! cm3/cm3 (input the appropriate
*                       initial water content of the
*                       layer for the treatment).

        thetas(i)=0.444
        thetfc(i)  0.25
        bd(i)= 1.467
        Kd(i)= 0.55
        Ks(i)=136.29
        be(i)=6.83
        psie(i)=-4.16
        conc(i) = 0.0

elseif(i .gt. 10 .and. i .le. 12) then
    theta(i)=          ! cm3/cm3 (input the appropriate
*                       initial water content of the
*                       layer for the treatment).

        thetas(i)=0.442
        thetfc(i)=0.2471
        bd(i)= 1.47
        Kd(i)= 0.55
        Ks(i)=42.74
        be(i)=7.48
        psie(i)=-4.27
        conc(i) = 0.0

elseif(i .gt. 12 .and. i .le. 14) then
    theta(i)=          ! cm3/cm3 (input the appropriate
*                       initial water content of the
*                       layer for the treatment).

        thetas(i)=0.487
        thetfc(i)=0.2663
        bd(i)= 1.35
        Kd(i)= 0.55
        Ks(i)=79.3
        be(i)=8.012
        psie(i)=-2.63
        conc(i) = 0.0

elseif(i .gt. 14 .and. i .le. 16) then
    theta(i)=          ! cm3/cm3 (input the appropriate
*                       initial water content of the
*                       layer for the treatment).

        thetas(i)=0.469
        thetfc(i)=0.2519
        bd(i)= 1.4
        Kd(i)= 0.55

```

```

        Ks(i)=15.1
        be(i)=7.47
        psie(i)=-3.19
        conc(i) = 0.0

    endif

        hydpot(i)=0
        psiz(i)=0
        hydgrad(i)=0
        flux(i)=0
        fluxs(i) = 0
        avhydcon(i)=0
        deltheta(i)=0
        delconc(i)= 0
        outflow(i)= 0.0
5      continue

*      The Executable part

*      Read irrigation information from File

        do 25 id=1,22

23      Read(7, 23) dac, irrig
        format (i2, 6x, f4.2)

        inf = irrig/50

* First estimate psim(i), psiz(i) and hydpot(i) for each layer
* using Campbells equations

        do 100 j=1,50
        z=0
        do 10 i=1,16
        psim(i)=psie(i)*(theta(i)/thetas(i))**(-be(i))
        psiz(i)=z-i*laythick+laythick/2
        hydpot(i)=psim(i)+psiz(i)
*      print *, 'i, psim(i), psiz(i), and hydpot(i) '
*      print *, i, psim(i), Psiz(i), hydpot(i)
10      continue

* Estimate K(i) from Campbells equation followed by the average of
* K(i)

        do 20 i=1,16
20      hydcon(i)=(Ks(i)*(theta(i)/thetas(i))**(2*be(i)+3))
        continue

        do 30 i=1,15
        avhydcon(i)=((hydcon(i)*hydcon(i+1))**0.5)/50
        hydgrad(i)=(hydpot(i)-hydpot(i+1))/(-laythick)
30      continue

```

```

do 50 i=1,15
outflow(i) = (theta(i)  thetfc(i))*laythick
if (outflow(i) .le. 0) outflow(i) = 0.0

retard(i) = 1 + bd(i)*Kd(i)/thetfc(i)
flux(i)=-avhydcon(i)*hydgrad(i) + outflow(i)
fluxs(i) = flux(i) * conc(i)/retard(i)
50  continue

do 55 i=1,16
store(i) = theta(i)*laythick
55  continue

storefc8 = 0.25*laythick

* Estimate change in theta
do 60 i=1,16
IF (i .eq. 1) then
deltheta(i)=- (flux(i)-inf)/laythick*dt
delconc(i) = -fluxs(i)/laythick*dt

elseif (i .gt. 1 .and. i .le. 15) then
deltheta(i)=- (flux(i)-flux(i-1))/laythick*dt
delconc(i) = - (fluxs(i) -fluxs(i-1))/laythick*dt
else
if (store(16) .ge. storefc8) then
outflo = store(16)-storefc8
else
outflo = 0
endif

deltheta(i)=- (outflo-flux(15))/laythick*dt
delconc(i)  -fluxs(15)/laythick*dt
ENDIF
60  continue

do 70 i=1,16
theta(i)=theta(i)+deltheta(i)
conc(i) = conc(i) + delconc(i)
if (conc(i) .le. 0) conc(i) = 0.0
if (theta(i) .ge. thetas(i)) theta(i) = thetas(i)
70  continue

100 continue

do 120 i=1,16
print*, 'dac, i, theta(i), conc(i)'
print*, dac, i, theta(i), conc(i)
write(8, 45) dac, i, theta(i), conc(i)
45  format(i2, 2x, i2, 3x, f4.3, 3x, f8.6)
120  continue
25  continue
stop
end

```

IRRIGATION DATA USED IN THE MODEL

INFILE1.DAT		INFILE2.DAT		INFILE3.DAT	
DAY	IRRIG	DAY	IRRIG	DAY	IRRIG
1	0.00	1	0.00	1	0.00
2	5.00	2	3.00	2	1.66
3	0.00	3	0.00	3	0.00
4	0.00	4	0.00	4	1.66
5	0.00	5	0.00	5	0.00
6	0.00	6	3.00	6	1.66
7	0.00	7	0.00	7	0.00
8	0.00	8	0.00	8	1.66
9	0.00	9	0.00	9	0.00
10	5.00	10	3.00	10	1.66
11	0.00	11	0.00	11	0.00
12	0.00	12	0.00	12	1.66
13	0.00	13	0.00	13	0.00
14	0.00	14	3.00	14	1.66
15	0.00	15	0.00	15	0.00
16	0.00	16	0.00	16	1.66
17	0.00	17	0.00	17	0.00
18	5.00	18	3.00	18	1.66
19	0.00	19	0.00	19	0.00
20	0.00	20	0.00	20	0.00
21	0.00	21	0.00	21	0.00
22	0.00	22	0.00	22	0.00