

**THE INTERMEDIA AGENDA-SETTING AMONG TWITTER, INSTAGRAM
AND ONLINE NEWS WEBSITES IN GHANA**

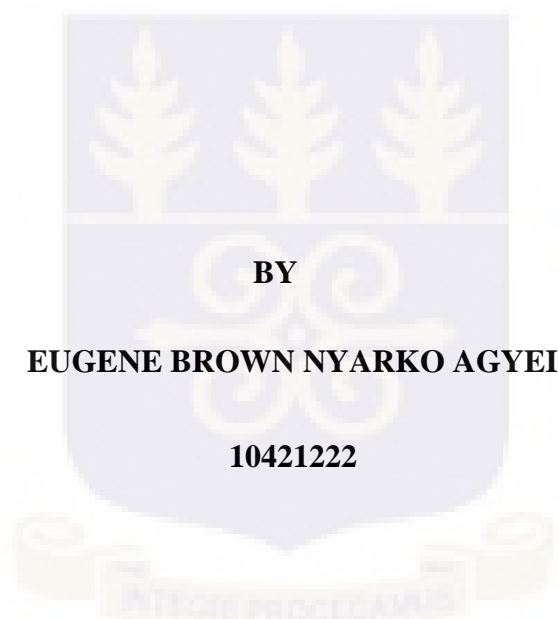

BY

EUGENE BROWN NYARKO AGYEI

10421222

**THIS THESIS IS SUBMITTED TO THE UNIVERSITY OF GHANA, LEGON, IN
PARTIAL FULFILMENT OF THE REQUIREMENT FOR THE AWARD OF MASTER
OF PHILOSOPHY IN COMMUNICATION STUDIES DEGREE**

JULY, 2019

DECLARATION

I declare that, aside from references to other people's works which have been duly acknowledged, this thesis is entirely the product of my own efforts. It was conducted at the Department of Communication Studies under the supervision of Dr. Sarah Akrofi-Quarcoo.

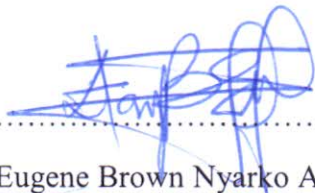

Eugene Brown Nyarko Agyei
(Student)

Date: August 07, 2020



Dr. Sarah Akrofi-Quarcoo
(Supervisor)

Date: 07/08/2020

DEDICATION

To my amazing mother, Adwoa Sakyibea, who would break her back for me any day so I can do better, and to my father, Yaw Agyei.

It is also dedicated to my supportive siblings - Biama, Asiedu and Nana, and to the memory of my beloved brother, Offei – I kept the promise.

ACKNOWLEDGEMENT

I give praises to God, for he has been good to me and his faithfulness endures forever. I am very grateful to him for giving me the strength to finish this work, that will partly, help me move to the next level of my life. Special thanks to my parents and siblings for their love, support and prayers throughout this tough, yet rewarding journey. I did this because you were there for me.

A special appreciation to my amazing and supportive supervisor, Dr. Sarah Akrofi-Quarcoo, for her consistent supervision and input, and for treating me more of a son than a student. Her constant guidance, motivation and corrections made this work see the light of day.

And to Professor Audrey Gadzekpo who has been more than supportive, I thank her for the mentorship and for always checking up on the progress of this work. The numerous opportunities she pushed my way will go a long way to impact my career in the future.

I am also grateful to the staff, faculty and the Class of 2017/2018 of the Department of Communication Studies and the School of Information and Communication Studies for their support and assistance. May they receive support from other people too when they need it.

Finally, to my amazing friends, my Team Alpha (Eileen, Lena, Baaba, Roger and Bekoe), I say thank you for the words of encouragement, the laughter and the priceless moments. Thank you for making me know that even though the task was huge, I was equally strong to execute it. Today, we can all rejoice because we crossed another hurdle in life. Although the journey has been rough, if you stop and look, it has been pretty amazing.

TABLE OF CONTENTS

DEDICATION	ii
ACKNOWLEDGEMENT	iii
ABSTRACT	viii
CHAPTER ONE	1
INTRODUCTION	1
1.0 Background to the study	1
1.1 Twitter and Instagram in the Global Context	4
1.2 Twitter and Instagram in Ghana	5
1.3 Problem Statement.....	8
1.4 Objectives of the study	10
1.5 Research Questions.....	11
1.6 Significance of Study and Justification	11
1.7 Operational definitions	13
1.8 Organization of Study.....	14
CHAPTER TWO	16
THEORETICAL FRAMEWORK	16
2.0 Introduction	16
2.1 Agenda-setting Theory	16
2.3 Intermedia Agenda-setting Theory	19
2.4 The Future of the Intermedia Agenda-setting Theory	23
2.5 Chapter Summary	24
LITERATURE REVIEW	25
3.0 Introduction	25
3.1 Intermedia agenda-setting and social media.....	25
3.2 Intermedia agenda-setting influences and online media.....	29
3.3 Intermedia agenda-setting influences on the global news flow	32
3.5 Chapter Summary	34
CHAPTER FOUR	36
METHODOLOGY	36
4.0 Introduction	36
4. 1 Research Design	36
4.2 Sampling Procedure.....	38
4.3 Sampled Media	39

4.3 Time Frame.....	40
4.4 Units of Analysis	41
4.5 Data Collection	42
4.6 Data Analysis.....	43
4.6 Coding Procedures and Coding Guide.....	46
4.7.1 Interview Guide	48
4.8 Intercoder Reliability Testing	48
4.9 Chapter Summary	49
CHAPTER FIVE	50
FINDINGS FROM THE STUDY.....	50
5.0 Introduction	50
5.1.1 Frequency of Issue Categories Across Media Over the Period	51
5.1.2 Comparing Media Agendas Between Twitter, Instagram and Online News Websites	54
5. 1.3 Results of Cross-Lagged Correlation Analyses.....	64
5.2 PRESENTATION OF QUALITATIVE FINDINGS	72
5.3 Results of In-depth Interviews.....	77
5.3.1 Influence of Social media agenda on online news media agenda.....	78
5.3.2 Social Media as a Source.....	79
5.3.2 Social Media Users as News Agents	80
5.4 Chapter Summary	81
CHAPTER SIX.....	82
DISCUSSION OF FINDINGS.....	82
6.0 Introduction	82
6.1 Twitter and Instagram Agenda Versus Online News Media Agenda in Ghana	82
6.2 Do Twitter and Instagram set their original agenda or just rehash what the Ghanaian online media has set?.....	84
6.3 How much influence does Twitter and Instagram’s agenda have over online media agenda in Ghana?.....	86
6.4 How much influence does Ghana’s online media agenda Twitter and Instagram’s agenda?.....	88
6.5 What is the intermedia relationship between Twitter and Instagram?.....	89
6.5 What role do Twitter and Instagram play in the news production process of online news media?.....	89
6.6 Chapter Summary	91
CHAPTER SEVEN	92
CONCLUSION AND RECOMMENDATIONS.....	92
7.0 Introduction	92

7.1 Summary of Key Findings.....	92
7.2 Limitations of the Study	94
7.3 Recommendations for Future Research.....	94
7.4 Conclusion.....	95
7.5 Chapter Summary	97
BIBLIOGRAPHY.....	98
APPENDIX A.....	106
APPENDIX B.....	1097
APPENDIX C	108

LIST OF TABLES

Table 1.0: Frequency Distribution of News Stories and Posts Across Media Over Time

Table 2.0: Frequency of Issue Categories on the Three Different Media Platforms across Time

Table 3.0: Comparing the Rank Order of Issue Categories Among Three Media Agendas

Table 4.0: Comparing the Frequency of Agendas Between Online News Websites and Twitter Over Time

Table 5.0: Comparing the Frequency of Agendas Between Online News Websites and Instagram Over Time

Table 6.0 Frequency of Issue Categories on Twitter Over the Period

Table 7.0 Frequency of Issue Categories on Instagram Over the Period

Table 8.0 Comparing the Frequency of Agendas Between Twitter and Instagram Over Time

Table 9.0 Frequency Distribution of Issues Categories of News Websites Across Time

Table 10.0 Top 5 Issue Categories on Twitter, Instagram and the news websites

LIST OF FIGURES

Figure 1: The cross-lagged correlation panel

Figure 2: Cross-lagged correlations of issue agendas between Twitter and the selected news websites

Figure 3: Cross-lagged correlations of issue agendas between Instagram and the selected News Websites

Figure 4: Cross-lagged correlations of issue agendas between the two social media (Instagram and Twitter) and the selected News Websites

Figure 5. Cross-lagged correlations of issue agendas between Twitter and Instagram

LIST OF ABBREVIATIONS

BBC – British Broadcasting Corporation

CNN – Cable News Network

GNA - Ghana News Agency

ABSTRACT

The rise of the internet has had a major impact on journalism development across the world, Ghana being no exception. Its influence can be seen in the rise of new media platforms such as online news websites, blogs and social media. As a result of this, the traditional notion of intermedia agenda-setting in Ghana, which existed among the legacy media has been questioned. This study explored the phenomenon of intermedia agenda-setting among two social media platforms — Twitter and Instagram — and five online news websites in Ghana over a two-week period in March 2019. Using a mixed method approach, the study investigated the different types of issue categories that dominated the agendas of Twitter and Instagram and how these in turn influenced the selected online media platforms namely *Myjoyonline.com*, *Citinewsroom.com*, *Yen.com.gh*, *Ghananewsagency.org* and *Pulse.com.gh*. News editors of two of the online media sampled were also interviewed to give more depth to the quantitative data. The study found that of the two social media, Twitter had the most influence on the news websites. Furthermore, Twitter also had an influence on Instagram. The findings further indicated that depending on topic and time, there was a bi-directional relationship between social media and the sampled online news websites, suggesting that there was an intermedia agenda-setting relationship among Twitter, Instagram and online news websites in Ghana. Interestingly, the study found that the news agenda on Instagram was dominated by topics relating to social issues like gender, sex and relationships. The study opens up for future studies to look into the intermedia agenda-setting influences among only online news websites in Ghana.

CHAPTER ONE

INTRODUCTION

1.0 Background to the study

In January 2018, a tweet about a primary school teacher in Ghana who teaches his pupils Information and Communication Technology (ICT) with a blackboard version of Microsoft Office went viral on Twitter. A Twitter user had copied the post from Facebook and mentioned Information Technology companies like Microsoft and Google in the tweet. Within few hours after the tweet had gone viral, the story appeared and gained prominence on major online news networks like the British Broadcasting Corporation (BBC), Guardian UK, Cable News Network (CNN), Tech Crunch and Joy News Channel in Ghana. The teacher, Richard Appiah Akoto, suddenly became a household name and discussions on quality education featured prominently on social media platforms in Ghana and, perhaps, globally. Subsequently, links of news stories on global media organizations were also shared by social media users. On social media platforms like Instagram where links could not be shared, screenshots of the news stories, as well as pictures of this teacher, were shared with the headlines as captions or comments. Both new and legacy media played a role in getting this news out there and subsequently raising several issues on Ghana's educational system.

The media play a very important role in society today. Inasmuch as they are regarded as the "fourth estate of the realm", acting as a check on government and other institutions (Luberda, 2008), they also give people what to think about every day (McCombs, 2004; McCombs & Shaw, 1972). The amount of attention the media devote to particular issues does not only influence how the public is going to accept the issue but also drives the kind of importance people attach to the given issue. These issues are regarded as the media's agenda. For some years now, a good number of empirical studies have perhaps given support to the fact that issues that form the mainstream media agenda may also influence the public agenda (McCombs & Shaw, 1976). On a daily basis, traditional media may publish a number of issues that they expect their audiences to engage with.

The underlying assumption of media agenda-setting is the power of the media to direct “what the public think about rather than what to think”.

The assumption was further explored by Dearing and Rogers (1996) to ascertain what influences the media’s agenda itself. Scholars have proposed that there is an interplay among media houses whereby apart from their audiences, they also influence one another. According to Dearing and Rogers (1996), “news people operate in a special kind of environment, without much contact with their audience members and so they take their cues about an issue's priority from other media”. These hints derive not only from an issue agenda's considerable importance, but also from its interest to the audiences and media consumers over which these media outlets compete. Presumably, with time, issues picked up by some media outlets also tended to influence what other news media put out. This later version of agenda-setting is what is referred to as intermedia agenda-setting. Intermedia agenda-setting focuses on how different media influence one another’s news agenda (Banducci, S., 2018; Sikanku, 2012). News media differ in power across the world. Those that are in powerful nations play several important roles in shaping the global news agenda. Furthermore, media firms with greater access to more quality news sources tend to have a greater influence on smaller news media who may not have a wide network of correspondents and or access to news sources (Cui and Wu, 2017).

Prior to the emergence of new media platforms like news websites and social media, the concept of intermedia agenda-setting existed in the thick of mainstream media such as newspapers, television and radio. In Ghana, for instance, both private and government-owned newspapers played critical roles in setting the news agenda (Amoakohene, 2004; Gadzekpo, 1997 cited in Sikanku, 2012). In his quest to investigate the intermedia agenda influences that existed between print and online media during Ghana’s emerging era of liberalization, Sikanku (2012) argued that

intermedia agenda-setting effects in Ghana's media landscape were varied. Morning shows on radio and television stations have for a long time adopted the newspaper review segment where topical issues in the various newspapers are rehashed, discussed and sometimes given newer dimensions. In short, newspapers usually set the content and tone for what may be discussed in other mainstream media. Several other scholars have argued that newspapers have a much higher agenda-setting influence on other media (Sikanku, 2012; Kilby, Thomas, Morani & Sambrook, 2016; Rogstad, 2016). Whether they were political, entertainment or social, some newspaper content was almost always likely to be included in daily radio and television discussion programmes. Subsequently, issues that may come out of these daily programmes on radio and television may also find their way into newspaper publications the following morning, therefore, making the influence mutual and cyclical.

It is assumed that media influence has been shifting from being among mainstream media only in Ghana to being among online and social media platforms due to an expanded media environment following the liberalization of Ghana's media landscape. Traditional media seem to be giving way to a variety of online media platforms which publish news quickly and faster. Additionally, there is also the emergence of a newer form of media, particularly, social media, which afford ordinary citizens the opportunity to create and share content as well as network with other people (Kaplan & Haenlein, 2010). Social media platforms like Facebook, Twitter, Instagram and YouTube have inarguably positioned themselves as part of the public sphere as important news sources and as platforms where public debates take place. The growth of the online media in Ghana and social media use has therefore impacted the agenda-setting function of the media in Ghana as anecdotal evidence suggests an intermedia-agenda setting relationship between the two.

1.1 Twitter and Instagram in the Global Context

Twitter and Instagram have become very important microblogging platforms for journalists, specifically, citizen journalists. Since, the first tweet on March 21, 2006, by Jack Dorsey, the creator of Twitter, the social networking site has seen an increase in its user base while also serving as a platform for news discussions. Twitter has proven to be a very powerful medium of disseminating news quickly, and sharing updates and opinions about issues. A variety of people, including citizens and people in authority, and leaders of various organizations have capitalized on its benefits of being able to share the 280-character messages known as ‘tweets’ (Hargittai & Litt, 2011, Rogstad, 2016; Kaplan & Haenlein, 2011). It is common knowledge that political actors such as Donald Trump, the president of the United States of America, use a social media site like Twitter to tweet his concerns on critical national issues. His tweets set the news agenda in online and mainstream media.

Instagram, which was released in 2010, was originally made for sharing photos and videos of people and their daily events. Over time, the social media application has been used for more than sharing photos of people to sharing updates of issues happening around them. Unlike Twitter, Instagram does not limit the number of characters. It therefore allows users to write long captions alongside the images or videos they share. Studies on Instagram suggest that since its inception, the social networking application has been used particularly by politicians in addition to already existing social networking applications as a “visual billboard” where they share information about their activities (Towner and and Munoz, 2018; Filimov, Russman & Stevenson, 2016).

According to the Pew Research Center (2015), former presidents of the United States of America such as Barack Obama adopted social media channels to frequently address Americans on a variety of issues. Tweets of personalities such as him serve as first-hand sources of information for

journalists and are quoted in news stories by big media organizations such as the BBC, Aljazeera and CNN.

Additionally, bloggers and freelance journalists also use Twitter and Instagram to share their stories, enabling people to comment and raise similar issues. Simply, Twitter and Instagram are no longer just for popular personalities in the entertainment industry but for personalities in politics, education and even religion because they allow for free exchange of ideas nationally and globally, between people who share in similar experiences who may or may not share the same ideas, providing them with the opportunity to engage in critical debate (Vonbum et al, 2016; Maclean et al, 2013). Some researchers have observed that Twitter has on several occasions defeated online and mainstream news outlets on several recent breaking international stories.

1.2 Twitter and Instagram in Ghana

According to the International Telecommunications Union, internet adoption rate in Ghana has increased substantially from 7.9 million in 2014 to an estimated 10.3 million users in 2019, representing about 35 per cent of Ghana's population. This suggests that more people will also be users of various social media platforms which, in its diverse forms, has become a basic use of the internet. Statistics by Global Stats Counter indicate that Ghana has 82.57% and 9.41% Facebook and Twitter users respectively. YouTube and Instagram follow with 2.66% and 1.1% users respectively (International Telecommunications Union, 2016; Global Stats Counter, 2018).

Twitter and Instagram are among popular social media platforms in Ghana. From tweeting and posting about musical concerts happening at weekends to lashing out at politicians, the two platforms are gradually taking on a form as newsrooms without the supervision of editors. The statistics of Twitter and Instagram users by *Globalstatscounter.com* as of January 2019 showed

that about 9.41% and 1.1% of the country's population are active Twitter and Instagram users respectively. People tweet their opinions, share news stories and engage with the tweets and posts of other people. In Ghana, the ownership of Twitter and Instagram accounts or handles is not limited to just individuals. The demand to get closer to consumers of news has made media organizations also create user accounts to share and interact with their followers. Several media houses in Ghana monitor the Twitter and Instagram accounts of newsmakers and prominent personalities. Whenever something of national interest happens, journalists presumably go right to the social media accounts of these prominent people to find out what they are saying about the issue. Their posts later become headlines and, in most cases, are used as quotes in news stories.

For instance, during the 2016 Presidential Elections in Ghana, media houses monitored the Twitter and Facebook accounts of all the contestants for days and hours up to the declaration of the results. Big online news organizations in Ghana such as Myjoyonline.com, Ghanaweb.com, Ghananewsagency.com and Citifmonline.com picked up congratulatory posts to Akufo-Addo that were published by presidential aspirants like Papa Kwesi Nduom and Edward Nasigre Mahama on their social media pages to use as quotes in their online stories. Some of the posts were written as scripts and used for radio and television news stories, supporting the latter with screenshots of the messages as evidence. Currently, almost all media houses in Ghana who operate online news websites have active social media pages through which they share content such as live news feeds, photos and short clips. The reporters for the online media in turn monitor what their followers are discussing to get fresh leads to stories.

According to the International Telecommunications Union, internet adoption rate in Ghana has increased substantially from 7.9 million in 2014 to an estimated 10.3 million users in 2019, representing about 35 per cent of Ghana's population. This suggests that more people will also be

users of various social media platforms which, in its diverse forms, has become a basic use of the internet. Though some of the statistics may not be too significant, it is known that these platforms receive considerable engagement on discussions ranging from the criticism of politicians to economic and social issues as well as entertainment. The use of hashtags has become a common phenomenon that social media users employ, sometimes, to engage in a particular conversation, whether fighting for a cause or drawing the attention of media organizations to particular issues. Hashtags like #DoSomething which was used on Twitter and Instagram to fight for a defiled four-year-old girl in Ghana drew the attention of the media to call on authorities to act quickly and give the girl justice.

Therefore, with the rise of social media use coupled with the rise of online news websites which deliver news in a faster way, there seem to be some kind of intermedia agenda-setting relationship between online news websites and social media in Ghana. Several traditional media organizations which operate television, radio and newspapers have vibrant online portals that publish stories before they are disseminated onto other platforms. Subsequently, they have become more interactive by paying attention to their social media platforms too. Live blogs of events, social media user posts and amateur videos are incorporated into their online feeds. Links and excerpts of stories are usually shared on social media for further discussion and reaction from social media users. Sometimes, the interactions on stories give online and mainstream media organizations other leads to follow. They also connect reporters to other offline sources as well as quotes to include in news stories. This is as a result of the comments that social media users add to the links before sharing. In view of this and giving how much engagement takes place on social media, journalists are constantly looking to tap into social media's news newsgathering potential while using it as a new tool to engage audience and distribute the news in a faster way (Knight and Cook, 2013;

Groshek & Groshek, 2013). At some point in time, trending issues on social media are developed from different angles as major news stories for online news websites.

In light of this, social media currently have some of kind influence on what content online media outlets produce (Krane, 2010). Because social media are very interactive, they afford users the luxury of publishing their own content directly and to equally engage with what online media produces by sharing, liking, retweeting and or commenting. Twitter, Instagram, Facebook and other social media have revived the question of ‘who sets the media’s agenda’. This question has been revived because, one underlying assumption of agenda-setting states clearly that the media’s focus on certain issues increases its perceived importance and shifts public attention to it, setting the public agenda but social media’s current active participation in news production in Ghana has made researchers curious about who now sets the media’s own agenda. Gross (2009) argues that this new technology has enabled ordinary citizens with no professional experience to become producers rather than mere consumers of information. Therefore, with this interplay, there seem to be some form of intermedia agenda-setting relationship between social media and online news websites in Ghana.

1.3 Problem Statement

Scholarship on journalism cultures outside Ghana point to the rise and importance of online news media and social media platforms not only as sources and transmitters of news but also as potential agenda-setters (Weimann and Brosius, 2016; Regan, 2015). Many others studies have also established the usefulness of social media to journalism, for example as potential sites for setting news agenda (Lysak et al., 2012; Kalsnes, 2016).

It is common knowledge that political actors such as Donald Trump, the president of the United States of America and John Dramani Mahama, former president of Ghana use a social media site like Twitter to tweet critical governance issues to member of their country. Their tweets set the news agenda in online and mainstream media. This study examines the phenomenon of intermedia agenda-setting among online news websites, Twitter and Instagram, a relatively newer social media networking platform.

While little empirical evidence exist in Ghana to ascertain the role of online media and social media platforms as sources of news and how they influence each other as agenda setters, anecdotal evidence suggests that Twitter and Instagram trends and activities are presumably beginning to influence news production cultures, specifically, newsgathering and circulation. Equally, the news agendas of online news websites are also changing the course of social media discussions.

Literature suggests, however that, most intermedia agenda studies that exist among new media have been done in the context of United Kingdom and Europe. Some of the studies have looked at the concept in specific periods such as during elections and campaign seasons (see:

Vonbum et al., 2016; Towner & Munoz, 2018; Sweetser et al. 2008; Lee, Lanceford & Lee ,2005; Ku, kaid and Pfau, 2003; Lennon, 1998). Additionally, Vliegthart and Walgrave, (2008) and Rogstad (2016) have argued that the number of studies that look at agenda-setting between different and emerging media is still limited.

Studies that exist on intermedia agenda-setting in Ghana have focused on how legacy media such as newspapers influenced television and radio content. Studies that have come close to understanding this concept with regards to new media in Ghana explored intermedia agenda-setting influences between print and online media and also between social media and mainstream

media (Sikanku, 2008, 2014; Katachie, 2017). The trend suggests that not much scholarly attention has been accorded to growing digital media environments like Ghana.

Twitter and Instagram trends and activities are presumably influencing news production cultures, specifically, newsgathering and circulation. Equally, the news agendas of online news websites are also changing the course of social media discussions. Therefore, adding to these reasons and the growth of online media and social media use in Ghana, it is prudent to look into the intermedia agenda-setting relationship among the two most vibrant social media sites in Ghana, Twitter and Instagram — which are currently regarded as new virtual communities — and selected online news websites in Ghana.

1.4 Objectives of the study

The primary objective of the study is to examine the intermedia agenda-setting relationship among Twitter, Instagram and online media in Ghana. Based on the recent increase in their usage, it is assumed that Twitter and Instagram, influence what gets into online media in Ghana. The specific objectives are:

1. To find whether the news agenda on twitter and Instagram reflect the agenda in Ghana's online media (Myjoyonline, Ghana News Agency (GNA), Yen.com.gh, Citinewsroom.com and Pulse.com.gh).
2. To examine the salient issues on Twitter and Instagram relative to what obtains on online news platforms.
3. To examine whether tweets and Instagram posts influence online media agenda in Ghana.
4. To explore how the news agenda of online media influences Twitter and

Instagram agenda in Ghana.

5. To investigate how intermedia agenda-setting works among social media.
6. To understand the role of social media sites like Twitter and Instagram in online news production processes.

1.5 Research Questions

The study seeks to answer the following questions:

RQ1: What categories of issues dominate the ‘agendas’ of Twitter, Instagram and online media in Ghana.

RQ2: Do Twitter and Instagram set their original agenda or just rehash what the Ghanaian online media has set?

RQ3: How much influence does Twitter and Instagram’s agenda have over Ghana’s online media agenda?

RQ4: How much influence does Ghana’s online media agenda have on Twitter and Instagram’s agenda?

RQ5: What is the intermedia relationship between Twitter and Instagram?

RQ6: What role do Twitter and Instagram play in the news production process of online news media?

1.6 Significance of Study and Justification

Even though technology has always been at the forefront of journalistic practice, new technologies have undoubtedly impacted the work of the media. Most studies have found that the advent of web-based technologies like Twitter and Instagram have allowed people to not only consume

media but to produce content (Weimann & Brosius, 2016; Gross, 2009 cited in Bird, 2011). As content producers, media consumers tend to set an agenda that are usually picked up by online and mainstream media. Particularly for online media, the flexibility in sharing links and the availability of content at almost every point in time encourages social media users to jump on the media agenda and share on various platforms.

With this new phenomenon, there is the need to look more critically at the intermedia agenda-setting influences among online news portals, Twitter and Instagram in the Ghanaian context especially at a time when the usage of the two social networking platforms is growing and gaining popularity among citizens, and has presumably become a newsgathering tool for journalists. For Ghana, this study is significant because of a particularly pressing global question of how new media platforms relate to newer and popular social media platforms like Twitter and Instagram. Morris & Ogan, (1996) posit that communication researchers have tended to focus on the more traditional forms of agenda-setting research such as the relationship between broadcast and print media, paying less attention to social media's agenda-setting influence.

This paper adds to the scant literature on intermedia agenda-setting influences between social media and online news portals in Ghana and of how both media influence one another's news agendas. It also contributes to digital journalism studies as a resource to help journalism practitioners and educators in Ghana understand how the intermedia agenda-setting influence works in an era of mobile content platforms like news websites, Twitter and Instagram where citizens also play the role of journalists by generating their own content.

1.7 Operational definitions

Social media: Internet-based applications and websites built on the ideological and technological foundations of Web 2.0 that allow users to create and share content or to participate in social interaction with other users (Kaplan & Haenlein, 2010).

New media: Digital technologies that offer access to content through web and mobile-based platforms anytime, anywhere, on any digital device and offer interactive user feedback and creative participation.

Salience: In agenda-setting, it refers to the perceived relative importance of a particular issue or topic (Erbring, Goldenberg & Miller, 1980). This study measured salience using frequency tables of issue categories.

Online media: Types of media that share information with the aid of the internet. In this study, online media refers to news websites and portals that deliver news through the internet. In this study, it may be used interchangeably with ‘news websites’ to refer to the selected news websites.

Twitter: It is a message-based social media platform that allows its users to share 280-character “feeds” of real-time updates and allows users to ‘follow’ other Twitter users.

Twittersphere: Refers to the entire population on Twitter in a particular location and their activities.

Tweets: The 280-character messages that Twitter users post for other users to see. Until 2017, tweets were limited to 140 characters.

Timeline: Is where users see all the tweets or posts of other users. It is mostly used for Facebook, Twitter and Instagram. It is also referred to as ‘TL’ in social media slang.

Instagram: Is a social networking app made for sharing photos and videos from a smartphone. Similar to Facebook or Twitter, everyone who creates an Instagram account has a profile and a news feed (Lifewire, 2018).

Posts: Pictures, videos or graphics shared on social media platforms, especially on Instagram and Facebook.

Hashtags: Denoted by the hash (#) symbol and are typically used to mark keywords or topics in a tweet.

Dumsor: A Ghanaian slang for consistent power outages. The term was coined from the Akan language in 2015 during Ghana's persistent electricity supply shortage.

1.8 Organization of Study

This study has been organized into seven chapters with Chapter One introducing the study and giving a background of what intermedia agenda-setting is and the various forms it has taken over time. The chapter also provided the problem statement that influenced this study, the objectives, the research objectives and significance of the study.

Chapter Two of the study discussed the theoretical framework in which the study is grounded. Previous studies that are related to this research are presented as a literature review in Chapter Three. The methodologies, theories, objectives, as well as the key findings of the studies, were discussed.

The methodology of this study was presented in Chapter Four. This chapter explained the research design, sampling procedure, data collection and data analysis methods that were employed for this study.

The Findings of the study has been presented in Chapter Five. The findings were discussed in relation to the theory used and other related studies in Chapter Six.

The study is concluded in Chapter Seven with a summary of key findings, recommendations for future research as well as the study's limitations.

CHAPTER TWO

THEORETICAL FRAMEWORK

2.0 Introduction

This chapter discusses the theory underpinning this study. The choice of this theory was heavily dependent on its appropriateness for this study. Additionally, it helped to achieve the objectives of the study, which was to examine the intermedia agenda-setting influence between social media and online media in Ghana. Although the main theory is agenda-setting, emphasis was placed on intermedia agenda-setting which is another level of the main theory.

2.1 Agenda-setting Theory

One of the core ideas of communication research has been to understand how the media affects the perceptions and attitudes of its audience members. Media effects have been one of the critical areas of interest for several media scholars (Vorderer, Park, & Lutz 2019; Bryant & Oliver, 2009; McCombs & Shaw, 1972). To understand why certain issues, gain huge public attention over others, agenda-setting studies have become one of the most significant areas of not only media and journalism studies but also of other related fields of communication such as international affairs and political science. The media's agenda-setting role has been considered to have its roots from a book published by Walter Lipmann in 1922 titled 'Public Opinion' (McCombs & Valenzuela, 2007). A chapter in the book which focuses on what Lipman (1992), describes as "the world outside and the pictures in our heads", sought to establish that most of the things people pay attention to or know about the world is largely based on the picture the media puts in their head. These pictures stem from the issues the media prioritizes and decide to tell its audiences (McCombs, 2011).

As defined by Dearing and Rogers (1976), an agenda is “a set of issues that are communicated in a hierarchy of importance at a point in time”. The agenda-setting theory proposes that what the media characterize as important is likely to be mirrored in what people will think or may see as important. Originally, the theory suggested that the media sets the public agenda in a way that “they may not exactly tell people what to think, but they may be successful at telling them what to think about” (McCombs, 2005, p. 13; Cohen, 1963). Agenda-setting scholars, McCombs and Shaw (1972) tried to explain why and how people perceive and rank social issues differently. Their study established that there was a significant amount of relationship between the amount of media coverage generated on specific issues and the rankings of importance by media consumers. They stated further that issue salience (perceived importance) is greatly influenced by the news media (Roberts, Wanta & Dzwo, 2002). In a later review of the theory by McCombs and Valenzuela (2007), the researchers state that:

The repetition of messages about public issues in the news day after day, along with the pervasiveness of the mass media in our daily lives, constitute a major source of journalism’s influence on the audience. The incidental nature of this learning, in turn, helps issues to move rather quickly from the media agenda to the public agenda (McCombs & Valenzuela, 2007, p.46).

Two basic assumptions underly agenda-setting research. The first is that the media does not reflect reality, they filter and shape it based on their concentration or the amount of salience they put on certain issues. The second underlying assumption posits that the media’s focus on a few issues and subjects leads the public to perceive those issues as more important than other issues (Twente, 2012). A meta-analytic study in 2018 analyzed the findings of 67 agenda-setting studies that were conducted from 1972 to 2015, gave evidence to the presence of news media’s influence on public agenda (Luo, Burley, Moe & Sui, 2018). The mean effect size of these studies showed an

indication of consistency in findings across the various studies which therefore indicated that the media had an effect on what people thought about certain public issues.

The agenda-setting theory was later categorized into three types by researchers Everett Rogers and J.W. Dearing (1988). According to them, agenda-setting comes in the following three forms: public, media and policy agenda-setting. Public agenda-setting focuses on the audience's agenda while media agenda-setting pays attention to mass media's influence on its audiences. Policy agenda-setting, which has not been further explored by the researchers, emphasizes how the media and public agendas might somehow influence the decisions of elite policy makers in the society (Freeland, 2012).

However, Lee (2012) argues that these three types may not be the only categories of agenda-setting currently as there are now a plethora of media available and communication has moved from being just one-way — where radio, television and newspapers force issues on their audiences — to a two-way model. This two-way model allows for people to share information and receive instant feedback, and also have access to so many more sources of information.

Earlier studies on the agenda-setting theory were preoccupied with finding the various actors who set the public agenda (Bakan & Melek, 2013). Because of that, additional studies have sought to mainly ground the agenda-setting theory in a global context. These studies were conducted in the different levels of the theory, significant among them, the intermedia agenda-setting theory, which has been described as the fourth level of the agenda setting theory and has gained prominence because of the availability of several different media channels.

Like many other theories, the agenda-setting theory has also faced criticisms. One of the criticisms is that it failed to predict the future of the media where technology, the internet and social media

will take a center stage in the industry. Feezelle (2018) further argues technological changes in information delivery systems such as the use of the internet and social media to share messages instantly and receive instant feedback raises the question of whether the basic assumptions of agenda-setting theory still hold and are applicable as they have previously been in the era where traditional media dominated. Weimann and Brosius, (2016) also point out that the emergence of new online media platforms has challenged the basic assumptions of the agenda-setting theory because, according to them, the media environment has changed dramatically.

But in the face of these criticisms, agenda-setting research has moved, though not entirely, from how the media influences its audiences to how different media influence each other's agendas (intermedia agenda-setting). It is also focusing on understanding how audiences influence media agendas especially with the availability of different media platforms where they can share their own opinions.

2.3 Intermedia Agenda-setting Theory

The intermedia agenda-setting theory is an offshoot of the main agenda-setting theory. It is considered as the fourth level of the original agenda-setting theory. The theory extends beyond McCombs and Shaw's (1972) initial agenda-setting hypothesis (Rogstad, 2016). Even though media influence on public opinion remains center-stage in agenda-setting discussion, a connected if less-researched line of enquiry includes understanding agenda-setting between or among various media.

The intermedia agenda-setting theory, which is critical to this study, is the process by which the news agenda of one medium influences the agenda of another (McCombs and Shaw, 1976; G. Lee, 2004; Golan, 2006). Simply, the intermedia agenda-setting theory suggests that media coverage in

one media has the ability to determine the agenda another media would focus on (Bakan & Melek, 2013). Another assertion of the intermedia agenda-setting theory is that reporters are likely to make their reporting decisions based on the news coverage of their peers at other news outlets (Sweetster, Golan and Wanta, 2008; Breed, 1995). Within mainstream media, early intermedia agenda-setting studies that followed McComb and Shaw's (1972) original agenda-setting research provided a strong evidence that newspapers had a strong influence on other media (Bakan & Melek, 2013). However, top news organizations in the world like the Cable News Network (CNN), British Broadcasting Corporation (BBC) and others are likely to influence one another and what other media outlets may publish or report. Following up on reports by other news outlets and replicating their content may be economical to the operations of media houses but on top of that, it allows for faster reporting. Equally, it enables media outlets go with the flow rather than spend more time looking for their own news leads. Harder et al. (2017) have indicated that intermedia agenda-setting helps indicate to reporters what the important issues of the day are as they take cues from other media houses.

Notwithstanding the internet became more vibrant after the intermedia agenda-setting theory was propounded, its impact on news media activities has been immense (Harder et al, 2017, Chadwick 2013). The diffusion of the internet has brought about new media channels such as social media, news websites and blogs. This development has affected intermedia agenda-setting as there is an interplay between members of the new media in setting the public agenda. Vombum et al. (2016) have noted that, with the recent increase in new media platforms, the agenda of online news media has become more influential on traditional news media agenda. This conclusion was drawn after studying Austria's multimedia news environment. Their finding, though limited to Austria,

suggested therefore that the intermedia agenda-setting role is gradually being reversed for the different types of media in which print media used to be the dominant agenda-setter. The swiftness with which online news websites and social media publish news is making them have more intermedia agenda-setting power. These two are however in competition of influencing each other. Previous media scholarship posit that social media activities are driving online news activities (Aral & Zhao, 2019).

In this current study, the theory is used to investigate how agendas are transferred from social media sites (Twitter and Instagram) to online news media in Ghana. The study also used the theory to understand how news coverage of the online news websites influenced discussions on the two social media networks in Ghana.

At the heart of these increasing dynamics between online media and social media lies the question of what the media agenda really is. The agenda of online media may usually be an aggregation of issues by top actors (bigger online media outlets) in the sphere and the hierarchy of it may be as a result of their own prioritization (Rogstad, 2016). Unlike online media agenda, the agenda on social networking sites like Twitter and Instagram are not necessarily from these actors – they are a collective effort of several Twitter and Instagram users whose actions such as posting, liking, sharing, commenting and retweeting posts may reinforce an agenda that has been set on the platforms, either by usually individuals who are not actors in the online media or necessarily have a very huge following. On Twitter for instance, retweets help posts to reach a bigger audience. Without taking into consideration the number of followers of the original Twitter user who tweeted, a retweet of that post reaches an average of about 1,000 people on the platform (Kwak, Park, Lee & Moon, 2010). However, Rogstad (2016), has suggested that researchers pay attention to the new phenomenon whereby online media use social media to share their content as an integral

part of their news coverage. The assumption is that journalists and news reporters have been described by some researchers as active users of social media platforms such as Twitter (Farhi, 2009; Hermida, 2010).

The findings of several studies have consistently been in support of the theory and found an existence of intermedia agenda-setting influence among social media networks and the mainstream media. Emerging studies are also trying to look at the intermedia agenda-setting dynamics in the various components of new media. According to Rogstad (2016), mainstream media agenda tended to influence Twitter agenda more than the other way round. Although these findings may not all point directly at a one-sided influence such as social media always influencing mainstream and online media agenda or vice versa, the consistency in those findings is that they have always shown a reciprocal influence among social media, mainstream and online media at different periods in time and these influences usually may exist for particular issue agendas.

However, against these new developments of the intermedia agenda-setting theory lies some basic challenges to some of the theory's basic assumptions. Harder et al., (2017) and Welbers (2016) point out that, the theory allows most researchers to do broader conclusions on issue categories and pay less attention to the specific news items that dominate the various categories. Typically, they argue that the intermedia agenda-setting theory should be interested in the basic news stories that form the bigger issue categories.

On the other hand, time lags, which is the duration between periods before issues are compared on different media, have also become an issue of debate. This is because the time it takes for news to travel across different media has been reduced as a result of technological advancement. Nonetheless, with the development of websites and social media where news spread quickly and

faster, the period between which one media can influence another media varies and should be taken into consideration (Weimann & Brosius, 2016).

Even though the time lag intervals have become more variable, Conway et al (2015) also argue that the strength of news stories may also contribute to how their influence may be. Some news stories gain fast traction while others may not, depending on the media outlet that reports it. This might make news stories that gain faster traction have stronger intermedia agenda-setting influence.

Additionally, when it comes to social media, the theory does not take into consideration the activities of the ordinary people who act individually as gatekeepers themselves and whose activities have an impact on various newsrooms. It categorizes the activities of everyone on these networking sites as one source.

2.4 The Future of the Intermedia Agenda-setting Theory

Just as agenda-setting scholars have argued that there are several distinct faces of agenda-setting theory, of which intermedia-agenda setting itself is one of them, the intermedia agenda-setting itself could see some new dynamics again especially with the diffusion of newer and social media (Kim, Kim & Zhou, 2014). Contrary to several previous studies that were geared towards intermedia agenda-setting among mainstream media — newspapers, radio and television — emerging studies are focusing on how social media like Twitter, Facebook and Instagram influence online and traditional media agenda, and the other way round. This is so because these platforms, although networking sites, have become virtual communities where public agenda can be measured. Therefore, their activities may invariably influence future research and make intermedia agenda-setting researchers look more to social media as a place where public agenda is now

formed. Additionally, the proponents of the theory have argued in later studies that the rise of social media makes room for intermedia agenda-setting research to be applied to an array of content that extends far beyond the traditional focus on mainstream media and public affairs.

2.5 Chapter Summary

This chapter discussed the theory underpinning this study. It presented and explained the agenda-setting theory and its core assumptions and some of the criticisms against the theory. It then proceeded to explain what has been described as another level of the agenda-setting theory, the intermedia agenda-setting theory, on which the research heavily depends. It also looked at the future of the theory and how new media can shape research in this field.

LITERATURE REVIEW

3.0 Introduction

Several scholarly works have sought, in one way or another to investigate the media's agenda-setting capabilities. While a number of these studies have tried to understand various phases of the media agenda-setting such as how they influence people on what to think about, others also have investigated the intermedia agenda-setting phase of it; seeking to find how the news agenda of some media can have an impact on the coverage of other media. With the rise of different forms of media channels, it became prudent for more research to also go into how the news agenda of some media channels influenced that of others. The diffusion of online and social media has taken intermedia agenda-setting to a new form with the two media influencing each other. This has made social media very relevant in the public sphere these days.

This chapter reviewed some of these studies to draw from them and show their relevance to this current study. For the sake of clarity and also to be able to make this review very meaningful, this chapter was divided into subcategories highlighting the various areas in which studies have been done under the subject. The first part focused on *intermedia agenda-setting and social media* while the second part also reviewed related literature on *agenda-setting influences and online media*. The third presented related studies on *intermedia agenda-setting influences on the global news flow*.

3.1 Intermedia agenda-setting and social media

In her study investigating intermedia agenda-setting between old and new media platforms in Norway, Rogstad (2016) tracked top tweets of the Norwegian 'Twittersphere' and top news headlines in the mainstream media, specifically newspapers. The study's main objective was to understand whether Twitter sets its agenda or just rehashes the mainstream media agenda.

Adopting a qualitative, approach, the study examined the relationship between Twitter and mainstream media content in an everyday context, trying to understand how the agendas relate to each other and how they differ in terms of the kinds of issues and news stories that receive attention on both platforms. The study spanned three ordinary news weeks with a “normal” news rhythm period in November 2011 and analyzed the ten top twitter topics in that time frame alongside the top news headlines from the leading Norwegian newspapers. Rogstad (2006) conceptualized the Twitter agenda as an aggregation of topics that received the highest volume of attention during this period on the platform.

In a three-step content analysis, findings from the study indicated that the agendas of both the Norwegian mainstream media and Twitter overlap on the salience of many issues (Rogstad, 2016). Moreover, the findings further showed that even though the agendas overlapped, Twitter was more concerned with engaging mainstream media content by tweeting, retweeting, commenting, liking, criticizing and referring to it. This study was beneficial to review for this research as it gives backing to how useful Twitter has become in the process of intermedia agenda-setting. The study also adopted Rogstad’s (2016) measure of what a Twitter agenda is.

In the context of Ghana, Katachie (2017) sought to find out social media’s influence on traditional media during the 2016 Presidential Elections. Using a mixed method approach, the study analyzed content from Twitter, four radio stations and two newspapers. After a cross-lagged correlation analyses, the findings suggested that Twitter had an influence on traditional media agenda. Furthermore, the study found that social media’s agenda-setting power was gradually increasing in Ghana because of its role in the newsgathering process.

In an earlier study by Skogerbo and Krumsvik (2015 in Norway, the researchers sought to establish and understand the intermedia agenda-setting relationship between social media and traditional news media in Norway. The study used the 2011 Norwegian election campaign period and gathered data from local politicians and traditional media. With this, after following and monitoring the posts of twenty-one (21) top local candidates of the elections on social media and analyzing data from print and online newspapers, Skogerbo and Krumsvik (2015) concluded that social media was not an established source for newspapers at the time and therefore there was little evidence that issues from these social networking applications contributed to agenda-setting in the newspapers.

In a related study, Bakan and Melek (2013), looked into the agenda-setting effects that occur between Twitter and the online versions of international newspapers. The online newspapers that were selected for the study were *The New York Times*, *The Daily Mail*, *The Guardian*, *The Telegraph* and *The Wall Street Journal*. The findings of this study, contrary to an earlier reviewed study by Skogerbo and Krumsvik (2015), suggests a significant amount of correlation in the similarity between the content of Twitter and mainstream media content in terms of tone. A limitation to this study, however, had to do with generalizability. The results of the findings could not be generalized as the intermedia agenda-setting phenomenon of Papal States because the study was conducted in a specific election period. This adds to the increasing literature of several intermedia agenda-setting studies conducted in election periods (see for instance: Harder, Sevenans and Aelst, 2017; Sweetser, Golan and Wanta, 2008; Golan, 2007) and therefore calls for more research into the concept during more regular periods.

The question of who sets the traditional media agenda or whose agenda influences the mainstream media agenda has been the interest area of several researchers, (See for instance: Lough &

Mohammed 2019; Rogstad 2016; Ku, Kaid & Pfau. 2003). A study by Conway, Kenski and Wang (2015) explored how the Twitter feeds of the 2012 presidential primary candidates influenced the issue agendas of the traditional news media in the United States. Using cross-lagged time series analysis, the researchers analyzed daily issue frequencies of both media and established that, there was an intermedia agenda-setting relationship between the agendas of Twitter posts and that of the traditional news. However, the study established that although there was a mutual relationship between tweets and traditional media news, the relationship was not bereft of different levels of strength and difference in time lags by issue. Another interesting finding of the study was that while traditional media followed candidates on certain topics, on others they are able to predict the political agenda on Twitter. Additionally, their findings also suggested that Twitter's influence on newspaper coverage during election times further backs the notion that politicians tend to influence even the media during these periods where as described by Dalton, Beck, Huckfeldt, and Koetzle (1998), they can use their energy and money to influence people.

Studies on intermedia agenda-setting among social media and mainstream media have predominantly focused on Twitter and Facebook, and their ability to share or transfer salience with mainstream media content. However, recent intermedia agenda-setting studies are also trying to understand how Instagram, a fairly new photo and video sharing social networking service (Towner & Munoz, 2017), is influencing various members of traditional media such as newspapers and in some cases, online media. For instance, a recent study by Towner and Munoz (2017) examined the intermedia agenda-setting effects between Instagram and mainstream newspapers during the 2016 United States Presidential campaign. The study sought to see whether the Instagram posts of Democratic and Republican candidates reflected in what mainstream newspapers published. After conducting a cross-lagged time series analysis, the results indicated

that there was a relationship between the posts of the candidates on some of the major issues in the campaign and the top issues in the papers (Towner & Munoz, 2017). Additional results of the same study demonstrated that the Instagram posts of the candidates predicted the issues agendas for the newspapers on certain key issues without any reverse effect.

The intermedia agenda-setting influences between social media and mainstream media have resulted from how much the latter has come to rely on the former in recent times. Lysak, Cremedaf and Wolf (2012) give evidence to the role social media play in television newsrooms. Some of the findings of their study suggested that most of their respondents who were journalists owned and managed social media accounts (Lysak, Cremedas and Wolf, 2012). With this, they used their accounts to share their stories and other reports they have embarked on. The effect of this is that journalists are likely to get cues from not only social media users but also know what their colleague journalists may be publishing there.

3.2 Intermedia agenda-setting influences and online media

To investigate how intermedia agenda influence operates in Africa's emerging era of media liberalization, Sikanku (2012) studied four major news publication outlets in Ghana; two nonnewspaper online publications (Ghana News Agency and Ghanaweb) and two print newspapers (*Daily Graphic* and *Daily Guide*).

Through a content analysis, Sikanku (2012) analyzed daily news reports of the two print newspapers as against the two online newspapers using a traditional cross-lagged time analysis to ascertain the intermedia agenda-setting relationship among print and online media in Ghana. The objective of the study was to determine how far online news services or newspapers in Ghana were leading in the competition of intermedia agenda-setting. Another major objective of Sikanku's

(2012) study was to understand the link between intermedia agenda-setting that involved state-owned and private news outlets.

The findings from the study indicated that the intermedia agenda-setting influences in Ghana are mixed. Sikanku (2011) content analyzed 322 news stories. These stories were curated between the hours of 5 O'clock am and 8 O'clock am as the researcher argued that these are the hours most of these outlets release their big headlines.

The study further found that of all the four media outlets, GNA had the most influence on the two print newspapers and even stronger influence on Ghanaweb. Sikanku (2013) suggested that GNA's dominance in the intermedia agenda-setting among the four publications could be attributed to its long existence and "first-mover advantage" owing to the fact that it has a wider or expansive network. However, the findings also point to the fact that "simply being print, online, government-owned or not government-owned does not mean that a publication has a strong intermedia agendasetting" (Sikanku, 2012).

In a related study of how the intermedia agenda-setting process works between online and traditional media in Austria, Vonbun, Königslöw and Schoenbach (2015) argued the emergence of the online media has challenged the assumed traditional role of the print media as agenda-setters. Another objective of their study was also to understand in a broader scope how intermedia agendasetting works in a multimedia news environment. Existing studies had said that media are not likely to be influenced because during electoral campaigns media are more likely to pay more attention to political actors (Vliegthart and Walgrave, 2008). In contrast to earlier studies, their findings suggested that intermedia agenda-setting influence exists between new and old media in Austria. Vonbun et al.'s finding from this study also gave insight in a way that suggests that a medium's opinion leader role may depend more on issue-specific characteristics of that medium.

The issue-specific characteristics may include ability of the particular medium to disrupt the normal news agenda of the day together with their proximity.

Vonbun et al. observed that online media dominated intermedia agenda-setting in Austria. They further concluded that quality online news media have the potential to act more generally as opinion-leaders. Journalists are more likely to monitor online and television news as news from these outlets are ‘faster’ and thus the two media are more likely to become agenda setters (Vliegenthart and Walgrave, 2008; Trumbo, 1995). Regardless, empirical evidence has failed to confirm the long-standing assumptions that TV news influences online news. Evidence from some studies has shown that newspapers rather tend to influence television news. The findings from this study also supports Sikanku’s findings that the *Ghana News Agency (GNA)*, a state-owned online news media in Ghana, led the intermedia agenda-setting influence in the country.

In one study of online and offline media during the 2014 Belgium election campaign, Harder et al., (2017), proposed and used a ‘news story’ analysis approach to map how news spread between different media. After analyzing 9,935 news items, their finding suggested that online news websites strongly affected other media types who did not have a faster publishing schedule. They noted that because online platforms and Twitter did not have any fixed publishing schedule, they were both relatively fast to carry news stories, reaffirming their prominent agenda-setting role.

This is because news consumers were always busy looking for information in distressful times.

They write;

“Television news and newspapers, in contrast, have fewer occasions to publish and are consequently relatively slow to cover news. Their ability to set other media platforms’ agenda is therefore limited (Harder et al., 2017)”.

Another study by Lee, Lanceforder and Lee (2005) sought to also understand the influence of internet bulletin boards on newspaper coverage of the 2000 General Elections in South Korea. The underlying objective of the study was to investigate the internet's influence on traditional news media during elections at both the first and second level of agenda-setting. Using content analyses and cross-lagged correlation of stories from major newspapers and internet bulletin boards during the campaign, the researchers found that newspapers influenced the internet bulletin boards at only the first level of agenda-setting during elections.

In contrast, the findings suggested that, at the second level of agenda-setting, newspapers were rather influenced by internet bulletin boards. Even with the reciprocity in some of the time spans of the study, the researchers concluded that the internet directs and leads public opinion while exerting influence on the coverage of other news media.

However, to test the hypothesis that the mainstream media agenda influences, to a large extent, the agenda of blogs, as against the contrary that the blog agenda rather has a strong influence on the mainstream media agenda (Wallsten, 2004), indicated that there is usually a relationship between the agenda of political blogs and that of mainstream media. Wallsten's (2004) study also indicated that blogs influenced each other and this influence usually occurred immediately, such as within a day rather than after a long time delay as was suggested by early intermedia agenda-setting scholars.

3.3 Intermedia agenda-setting influences on the global news flow

The global newsroom practices continue to be shaped by intermedia agenda-setting influences. In their bid to examine agenda-setting attributes in newspaper coverage of the missing flight MH370

incident in the United States, China and Hong Kong, a study by Cui and Wu (2017) analyzed the media coverage of the MH370 as covered by *The Washington Post*, *Global Times* and *Ming Pao* – a Hong Kong newspaper. The study coded first-hand sources that included quotes from Malaysian Airline employees, experts and other government officials, and subsequently coded media sources (Cui & Wu, 2017).

After analyzing 255 news articles, findings from the study showed meaningful correlations among the issue agendas of the three sampled newspapers. It also found an asymmetrical influence among the news media in the United States, China and Hong Kong. Additionally, Cui and Wui's (2017) study has shown that news organizations in high power countries play key roles in intermedia agenda-setting by shaping the international news agenda.

Intermedia agenda-setting has proven in other studies to affect the global news flow. According to Golan (2006) the newsworthiness of certain major international events may be as a result of an intermedia agenda-setting effects.

The idea behind Golan's (2006) study was to understand how the international coverage of morning newspapers influenced what other news media may report on their international evening news programs. He studied the *New York Times Newspaper* alongside three television network news programs of ABC, NBC and CBS television networks. A content analysis of the stories on all four media implied a strong association between the international news agenda of the New York Times and the international news agendas of the news programs of the three television networks. Golan (2006) argued that it was the New York Times that influenced the content of the television programs. He stated:

“Since the *New York Times* is published in the morning and the television broadcasts during the evening, it will be argued that it is the New York Times’s coverage that is somehow influencing network coverage of international affairs, (Golan, 2006)”.

The study further suggested that the kind of stories that get into the news in media outlets may not always be the sole judgement of editors or gatekeepers or by other news determinants but mostly by the news agenda of other news media. With the limitations of the study in mind which was the fact that time cycles of news publications are not limited to a 24-hour cycle, Golan (2006) admitted that the news coverage of the *New York Times* was also likely to be influenced by the evening broadcasts of the three television networks.

In another study to explore how the news media in different countries influenced each other in reporting international news, a big data analysis of 4,708 online news was done by Guo & Vargo (2017). These stories were sourced from 67 countries in 2015. The study found that top and wealthier countries did not only attract the attention of the world news media as had been indicated by Cui and Wui (2017), they were powerful enough to even decide how other countries perceived the world.

Interestingly, the study also concludes that in terms of online media, emerging media in core countries are not necessarily more powerful than media in semi-peripheral and peripheral countries in setting the international news agenda. This could be because the internet has no physical boundaries.

3.5 Chapter Summary

This chapter reviewed related studies in intermedia agenda agenda-setting that were useful to this research. It focused on studies in intermedia agenda-setting and social media, intermedia agenda-setting and how it

influences the global news flow as well. Studies relating to how content transfers between mainstream media were also reviewed.

CHAPTER FOUR

METHODOLOGY

4.0 Introduction

This chapter explains the methodology used. It focuses on explaining the research design, sampling procedures, unit of analysis, data collection methods, coding procedures and the data analyses methods that were used.

4.1 Research Design

The research design used for this study was to help ensure that the data gathered will adequately answer the research questions as clearly and unambiguously as possible, as well as fulfil the study's research objectives.

A mixed method approach was adopted for this study. The approach, which is otherwise referred to as blended research or mixed research by some researchers “involves collecting, analyzing, and interpreting quantitative and qualitative data in a single study or in a series of studies that investigate the same underlying phenomenon” (Onwuegbuzie & Dickinson, 2008). The mixed method approach helps a research problem to be examined in different ways. A major reason for using the mixed methods approach is that, several of the previous studies on intermedia agenda-setting research adopted the quantitative method (see for instance: Lim, 2011; Meraz, 2011) The result of that approach is that it does not encourage in-depth analysis of issue categories and news stories or topics that came up during the period of the study. Kalsnes (2006) has argued in a similar study that the mixed method approach can add more knowledge to the findings of intermedia agenda-setting studies. Therefore, this study used both a quantitative and qualitative method.

The quantitative aspect consisted of a content analysis of tweets, Instagram posts and news stories from the selected online media across the period of the study. As defined by Babbie (2012), content analysis is the study of recorded human communications, such as texts, books, websites, paintings or graphics and law. Wimmer and Dominick (2006) also define content analysis as a method of studying and analyzing communication in an objective, systematic qualitative or quantitative approach. Literature shows that several previous agenda-setting studies have been conducted using quantitative content analysis or have combined this method with other methods such as semi structured interviews (Towner & Munoz, 2018; Lee, 2017; Balan & Melek, 2013; Kalsnes, 2006). News items, Instagram posts and tweets that were collected during data collection were presented using frequency tables. This helped to find the number of occurrences of various issues under the categories.

Additionally, to measure the influence of one media over another, the study chose the cross-lagged correlation with the Rozelle-Campbell baseline analysis. It is the type of correlation which has been used by several intermedia agenda-setting scholars to measure one medium's influence over another (see for instance Lopez-Escobar, Llamas, McCombs & Lennon, 1998; Sweetser et al., 2008; Wanta et al., 2004). Cross-lagged correlation analyses allow a researcher to investigate causal inferences from correlational data. In this study, the cross-lagged correlation analysis was conducted to help examine some of the research questions that the study sought to answer. This was to measure and understand the intermedia-agenda-setting relationship that existed among Twitter, Instagram and online news media in Ghana.

The qualitative aspect involved a content analysis of the top five ranking issue categories over the study period. Topics and news stories served as the unit of analysis. The purpose of this was to

find out what influenced their frequency and their popularity on the three platforms combined. The number of retweets, likes and comments were analyzed. Additionally, for items from Instagram and Twitter, the study investigated the actors who shared contents on the platforms.

Furthermore, interviews of two editors of the selected online news portals were conducted and analyzed to supplement and give depth to the findings from the quantitative data.

4.2 Sampling Procedure

One of the key components of every good research is the appropriateness of the sample used. Five online news websites (*Myjoyonline.com*, *Pulse.com.gh*, *Citinewsroom.com*, *Yen.com.gh* and *Ghananewsagency.org*) were purposively sampled. Their choice was based on the 2018 Alexa ranking of the most visited online news websites in Ghana. Alexa is a global pioneer in the world of analytical insight that measures how websites are doing relative to all other websites on the web (Alexa, 2018).

Additionally, guided by previous intermedia agenda-setting studies (Rogstad, 2016; Towner and Munoz, 2017; Zhang, 2018), the five online news websites were not arrived at based on their readership alone but also their ability to set news agenda for one another and social media. While intermedia agenda-setting studies may usually use quantitative sampling approaches, some agenda-setting scholars (Rogstad, 2016; Bryman, 2006) have suggested that purposive or judgmental sampling, with a logical backing, can be used for agenda-setting investigations. Also, because this study used a mixed method approach, purposive sampling was suitable.

Twitter and Instagram were also purposively sampled because of their interactive nature in the Ghanaian social media landscape.

For the qualitative aspect, the sum of the frequencies of various issues under the issue categories on all three media were ranked. The top five among them were selected and analyzed to find the dominant news stories, Instagram posts and tweets that dominated the issue categories.

Also, the study used purposive sampling to select two editors of the sampled news websites. The study selected the editors of Yen.com.gh and Ghananewsagency.org.

4.3 Sampled Media

Twitter and Instagram are very useful social media platforms in Ghana's internet space. Anecdotal evidence shows that the engagements on the two social media platforms are gradually making them a part of news production activities in the online news media. Quotes and links are embedded in stories because of their easy access. In 2019, Twitter reported that it had about 330 million active monthly users worldwide and received about 350,000 tweets per minute, (Statista, 2019; Internetlivestats, 2019). While there may be a small number of active Twitter users in Ghana (9.48%) (Global Stats Counter, 2019), the activities on the platform and their role in news production activities make it necessary for it to be studied.

On the other hand, Instagram is fairly new but its usage in Ghana in terms of membership and diverse discussions keeps increasing. For instance, active users of Instagram in Ghana moved from 0.99% in December 2018 to an estimated 1.8% in May 2019. With its ability to easily capture and share photos and videos with captions, the platform has become a very important tool for not only citizens but also advertisers and politicians, thus making it useful for an intermedia agenda-setting study like this. Moving a little away from its intended purpose, users now share images or screenshots of news stories and use the caption section to either write the headlines or give summaries of the stories. Sometimes, screenshots of excerpts of the stories are shared as photos.

The five selected online news websites for this study; *Myjoyonline.com*, *Pulse.com.gh*, *Citinewsroom.com*, *Yen.com.gh*, and *Ghananewsagency.com*, offer their audience a comprehensive online source for up to date news about politics, sports, entertainment, business and other topics regarding Ghana and the African continent. The other two websites, *Pulse.com.gh* and *Yen.com.gh*, although they report on similar topics as the three mentioned above, they (*Pulse.com.gh* and *Yen.com.gh*) are more inclined towards publishing more entertainment stories. Of all the five websites, *Ghananewsagency.org* is the only state-owned portal.

4.3 Time Frame

Time frame is a very important component in intermedia agenda-setting studies. The importance of choosing a time frame is to help the study be conducted in a specific period. The time frame is the entire period in which an intermedia agenda-setting study is conducted. The time frame is further divided into time spans. The time spans are usually hours, days or weeks within which time lags have been left so that they (time spans) could be tested against each one another for intermedia agenda-setting effects. The time lag is the period between the time spans in which causal effects can happen. It could range from hours to weeks (Wayne, Wanta & Dzwo, 2002). Winter and Eyal (1981) recommended that, the optimum time span for examining agenda-setting effects is four weeks or more. Stone and McCombs (1981) also proposed that for the media's agenda to be on the public agenda, it takes two (2) to four (4) months which means that the time lag between these periods should be more than days. However, after testing several hypotheses, Roger et al. (2002), have recommended that the time spans could be a number of days while the time lag could range from one day to one week. Their argument is based on the premise that, the sharing of news and information on internet-based media and social media happens very quickly and that people are

naturally likely to discuss issues when they have occurred within a few days than wait for a long time when the issues have died down (Roger et al., 2002).

Based on the recommendations above, this study was conducted over a two-week period (time frame) in March. The study period was from March 17 to March 31, 2019. The basis for selecting the month of March was to do this study in a 'routine' news period where there were no events such as elections that would take over the news and social media activities. The study time frame was divided into four time spans with a time lag of one day. Several studies have argued and shown that a one-day time lag interval is appropriate for online intermedia agenda-setting to occur (Bakan and Melek, 2013; Vliegenthart and Walgrave, 2008). The time spans are as follows:

1. **Time 1** - 17th - 19th March
2. **Time 2** – 21st - 23rd March
3. **Time 3** – 25th - 27th March
4. **Time 4** – 29th – 31st March

The four-time spans were suitable for the study because preliminary intermedia agenda-setting studies that involved new and internet-based media have proven that a two-time span period was not suitable for examining intermedia agenda-setting influence (Bakan and Melek, 2013; Vliegenthart and Walgrave, 2008; Lee, Lancendorfer and Lee, 2005; Roger et al., 2002)). The daily time frame was from 6:00am to 6:00pm. The reason for choosing an extended daily time frame was because online media mostly do all-round publishing throughout the day.

4.4 Units of Analysis

Social science research scholar Earl Babbie (2011) defines units of analysis as “the what or whom being studied”. For the purpose of this study, the unit of analysis consisted of all the trending tweets

and Instagram posts that appeared on the two social media platforms from the 17th of March to the 31st of March between the hours of 6:00:am and 6:00pm. For Twitter, the tweets were part of the top 10 trending topics the time frame under consideration and should have at least been retweeted or liked more than twenty (20) times. At every point in time, Twitter gives users the opportunity to see the top trending topics being discussed in their country on the platform. Under these trending topics were different tweets that pointed to the same issue. For Instagram, the posts were items that appeared in the ‘*explore*’ section within the period.

Additionally, the units of analysis also consisted of all news articles on the homepages/frontpages of the sampled online news portals, *Myjoyonline.com*, *Pulse.com.gh*, *Citinewsroom.com*, *Yen.com.gh*, and *Ghananewsagency.com*, within the same study time frame. The logic behind choosing stories on the homepage was based on the fact that, for news websites to draw attention to specific stories, they tend to place those stories on the homepages. Besides that, new stories also may usually stay on the homepages for a while before they move to other inside pages of the website.

For the qualitative part of this study, transcripts of semi-structured in-depth interviews of two editors, one from each of the sampled online websites were analyzed as the unit of analysis. The findings from the interviews were analyzed thematically to find patterns in the data that were interesting to the study and contributed new dynamics to the quantitative data.

4.5 Data Collection

Tweets and Instagram posts were collected daily within the time frame. Tweets were gathered by basic monitoring procedure in which Ghanaian Twitter was observed from an account that was created specifically for this study. The inclusion criteria were that before a tweet was selected as

part of the data, it should have been part of the top ten trending topics on the platform. Additionally, the tweet should also have been either retweeted, liked or commented on at least twenty (20) times). Ghanaian Twitter receives a lot of tweets per second and not all of them get attention therefore the sampling was limited to tweets that had been retweeted, liked or commented on at least twenty (20) times to allow for only the most relevant tweets to be sampled. The exclusion criteria used was that, individual posts about personal issues, jokes and funny comments that had nothing to do with the identified issue categories or topics were not coded.

Because Instagram is relatively new and there is not a very clear mechanism for collecting its data for research projects such as this, the study employed the data collection method of a previous Instagram study by Towner and Munoz (2017). Captions of posts that appeared within the time frame were coded. Personal posts which did not fall under any issue category were not included.

With the five selected online news platforms, a basic coding procedure was conducted. The front pages or homepages of *Myjoyonline.com*, *Pulse.com.gh*, *Citinewsroom.com*, *Yen.com.gh*, and *Ghananewsagency.com* were visited during the study period and stories were coded under the various issue categories as presented in the coding guide. The front pages were selected because online news media and even mainstream media were likely to put their top contents on those pages.

An interview guide was used to interview two editors of the selected online news portals. The interview was semi-structured and the guide was based on some of the findings from the data gathered from the quantitative aspect of this study.

4.6 Data Analysis

With the aid of the Statistical Packages for Social Sciences (SPSS), the data collected was cleaned, organized and analyzed. The first part of the analysis consisted of running descriptive statistics of

the data. This helped to find the frequency of issues that appeared under the different issue categories in the various media across the study period.

On the second level, to realize the objectives of this study and connect it to existing intermedia agenda-setting literature, cross-lagged time-series correlation with the Rozelle-Campbell baseline analysis was conducted on the data. This helped to explore the intermedia agenda-setting influences across the four main time spans. This was to measure the transfer of salience across the two-week period across the various media. Basically, the analysis focused on how salience was transferred among Twitter, Instagram and the selected online news portals during the time frame. The cross-lagged correlation also helped to investigate how the three media platforms influenced one another on specific issues in different time spans.

The assumption of the cross-lagged correlation is that if media X causes media Y more than media Y causes media X, then media X at Time 1 correlated with media Y at Time 2 ($PX1Y2$) should be higher than media X at Time 2 and Media Y at Time 1 ($PX2Y1$) (Campbell & Kenny, 1999). The inverse that if media Y causes media X at Time 2 more than media X at Time 2 causes media Y at Time 1 ($PX2Y1$) should be higher than media X at Time 1 and media Y at Time 2 ($PX1Y2$) is also presumed. In this study therefore, three cross-lagged correlations can be performed, that is between Time 1 and Time 2, Time 2 and Time 3 and also between Time 3 and Time 4 among the various media sampled.

Lopez-Escobar et al. (1998) proposed that some advantages come with employing cross-lagged correlation analysis. The first advantage, they state, is that two opposing hypotheses can be tested simultaneously. For instance, in this study, to answer RQ3, RQ4 and RQ5 which seeks to measure the amount of influence that existed among online news media, Twitter and Instagram's agenda

during the time spans, the researcher can assess, for example, the relationship between Instagram at Time 1 and Time 2 and equally do the opposite of it too. The other advantage to using the cross lagged correlation is that, the results can be examined based on the Rozelle-Campbell baseline analysis. The Rozelle-Campbell baseline, the level of correlation to be expected based on the autocorrelations, helps researchers to determine the significance of the cross-lagged correlation coefficients. According to McCombs and Shaw (2004), the Rozelle-Campbell baseline means that the value occurred by chance.

Also, aside from the results of correlations producing significant coefficients, for the cross-lagged correlations to be able to detect a clear intermedia agenda-setting, other two conditions needed to occur between the time spans. In the case of this study in mind for instance, the first condition suggests that the cross-lagged coefficient of salience between Time 1 of Instagram and and Time 2 of the news websites should be above the Rozelle-Campbell baseline, that is $(PX1Y2) > (RC)$. The second condition was that the cross-lagged correlation coefficient between the news websites at Time 1 and Instagram at Time 2 should be below the Rozelle-Campbell baseline figure calculated

$(PY1X2) < (RC)$ (Lim, 2008). The formula for calculating the baseline was $[(PX1Y1 + PX2Y2)/2] / [(PX1X2)^2 + (PY1Y2)^2] / 2$ (Rozelle & Campbell, 1969).

Therefore, to measure the influence among online media, Twitter and Instagram agendas, a number of cross-lagged correlations were performed for this study.

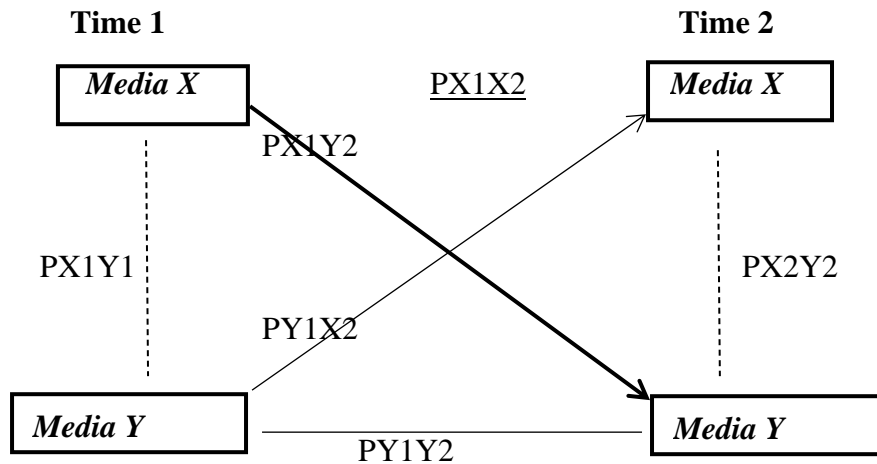
Figure 1.0 The cross-lagged correlation panel

Furthermore, there was a qualitative analysis of the top five ranking issue categories and topics (News stories, tweets or Instagram posts) that received huge mentions under the issue categories. The aim of this analysis was, among other things, to situate them in context and understand reasons why certain issues gained more salience than others on all media platforms. Here, the top five (5) ranking issue categories were given a close look. The data was scanned for specific news stories, tweets and Instagram posts that dominated these categories. They were analyzed for the tone of language and interactions they received.

Finally, there was a thematic analysis of interviews with two news editors of the sampled news websites. Themes were generated and discussed in relation to the objectives and questions of this study while situating them in the context of related studies and theory underpinning this current study.

4.6 Coding Procedures and Coding Guide

Before the actual coding, there was a careful examination and preliminary collection of data on the selected platforms for three days which enabled the generation of the various issue categories.

After that, items collected from Twitter, Instagram and the online news websites within the time frame (March 17 – March 31) were placed under the issue categories generated using a basic coding procedure.

Twelve (12) themes were identified and categorized as the issue topics. Some of the related themes were merged to give the issues a wider scope. Below are the issue categories:

1. **Elections, electoral violence and vigilantism:** News articles, tweets and posts relating to electoral violence issues, for example, the Ayawaso by-election violence, political party vigilantism, electoral commission, upcoming presidential polls etc.
2. **Politics, corruption and governance:** News articles, tweets and posts relating to corrupt officials, local governance, misappropriation of funds, ministries, new government projects etc.
3. **Economy, cedi depreciation and employment:** News, tweets and posts relating to economic crisis, businesses, new economic policies, labour strikes, unemployment issues, falling of the cedi, government's promises to rescue the cedi, cedi-dollar rate etc.
4. **Security, kidnapping and crime:** News and posts relating to kidnappings, violence, robbery, mobile money scams etc.
5. **Electricity (Dumsor), energy and transport:** News, tweets and posts related to power cuts, PDS, ECG, 'Dumsor', accidents, road issues, traffic problems, energy etc.
6. **Entertainment and celebrity scandals:** News, tweets and posts related to entertainment, celebrity scandals, celebrity lifestyles, gossip, music etc.
7. **Education, youth and technology:** News, tweets and posts relating to free SHS, law school and teacher trainee licensure exams, Double track system, teacher association strikes, education policies etc.

8. **Foreign and local sports:** News, tweets and posts related to football, athletics, foreign sports, local league, football stars, Ghana Football Association Normalization committee reports, African Cup of Nations etc.
9. **Social issues:** News, tweets and posts relating to women and men issues, children, domestic violence, women empowerment, sex, relationship issues etc.
10. **Religion and Spirituality:** News, tweets and posts relating to church issues, religious views by prominent people, controversial spiritual issues etc.
11. **Foreign news commentary:** News, tweets and posts about other countries, crisis in other countries commented on by Ghanaians etc.
12. **Health, lifestyle and sanitation:** News, tweets and posts about health issues, lifestyle, sanitation, flooding and sanitation related matters.

4.7.1 Interview Guide

Follow-up interviews were conducted with two of the editors of the sampled online news websites to collect in-depth information to support the quantitative data. Therefore, a semi-structured interview guide was generated to ask them questions. After seeking permission from the respondents, the interview was recorded. Follow up questions that were not in the interview guide were asked.

4.8 Intercoder Reliability Testing

An intercoder reliability test was conducted using Cohen's Kappa inter-coder reliability test to guarantee the reliability of the data collected for the first part of this study. An MA student with the Department was assigned to code about 15 per cent of the data gathered. The student was taken through the meanings of the various issues categories that had been generated as well as the

meaning of the time frames. After an agreement had been established between the researcher and the student the researcher, the student was given 20 per cent of the data to code alongside the researcher. The result of the test was 0.91 which suggested a high level of agreement between the two coders. When running Cohen's Kappa Intercoder Reliability for any studies, results greater than 0.60 are acceptable.

4.9 Chapter Summary

In this chapter, the research design that was used for this study discussed. It explained the mixed method approach that was used for this study, reasons behind the choice of this methodology as well as its benefits to the study. The chapter also presented and explained the sampling procedures, data collection methods, coding procedures and data analysis methods. The methodology of this study was guided by a combination of methodologies that have been used in previous studies.

CHAPTER FIVE

FINDINGS FROM THE STUDY

5.0 Introduction

The issue of social media's impact on online news media and vice versa has been an interesting area of research for many media effects research scholars. The results of their works, although in different time periods and contexts, have shown a reciprocal influence of issue agendas between social media and online media. Even though a lot has been done in the field over the years, empirical evidence shows that little has been done to localize the knowledge on this subject within the Ghanaian context. In this chapter, therefore, findings from this study are presented.

The main objective of this study was to investigate the intermedia agenda-setting influences among Twitter, Instagram and selected online news portals (*Myjoyonline.com*, *Yen.com.gh*, *Ghananewsagency.org*, *Pulse.com.gh* and *Citinewsroom.com*) in Ghana. Also, the different kinds of agendas that dominate the three media platforms under study were investigated.

Findings from the quantitative aspect of this research was presented using statistical descriptive tools such as frequency tables. The outcome of the cross-lagged correlation analyses and Rozelle-Campbell baselines were also presented using cross-lagged panels.

Additionally, the chapter also presented thematic analyses of in-depth interviews of two editors of the sampled online news websites. To make for easy comprehension, the findings were presented separately for both the qualitative and quantitative aspect of this study.

5.1 PRESENTATION OF QUANTITATIVE FINDINGS

5.1.1 Frequency of Issue Categories Across Media Over the Period

The data for the study was collected over a two-week period in March 2019. The period had a normal news pattern and was divided into four time spans or periods with a day time lag between those periods. Table 1.0 below gives an overview of the total number of posts and news stories that were collected over the period.

Table 1.0 Frequency Distribution of News Stories and Posts Across Media Over Time

Media	Time 1	Time 2	Time 3	Time 4	Total
Twitter	75	228	300	202	805
Instagram	36	23	49	38	146
News Websites	165	366	178	136	845
Total	276	617	527	376	1,796

Throughout the two-week period, a total of 1,796 items were coded from Twitter, Instagram and the selected online news websites (*Myjoyonline.com*, *Yen.com.gh*, *Ghananewsagency.org*, *Pulse.com.gh* and *Citinewsroom.com*). The various number of issues were 276 in Time 1, 617 in Time 2, 527 in Time 3 and 376 in Time 4. Out of the four time spans, Time 2 (March 21 – March 23) received the highest number of items (n=617) from all three media, making up one third or 31.2 per cent of the data. It is also seen that Time 1 had the least number of items (n=276).

Of the 1,796 units analyzed, 845 units were posts from the homepages of the selected online news websites representing 42.7 per cent of the entire number of items collected over the period. Twitter followed closely with 42 per cent. Instagram received the lowest number of posts.

The study grouped issues into twelve (12) categories. These categories were arrived at after an initial three-day study of Twitter, Instagram and the selected online news websites. Generally, the frequency of issue coverage from one time span to another tended to fluctuate. The next chart gives an insight into the frequency of the various issue categories on all three media.

Table 2.0 Frequency of Issue Categories on the Three Different Media Platforms across Time

Issue Categories	Frequency	Percentage
Elections, electoral violence and vigilantism	61	3.4%
Politics, corruption and governance	193	10.9%
Economy, Cedi depreciation and Employment	176	9.8%
Security, kidnapping and crime	144	8%
Electricity (Dumsor) and transport	216	12%
Entertainment and celebrity scandals	346	19.3%
Education, youth and technology	148	8.2%
Local and foreign sports news	146	8.1%
Social issues	149	8.3%
Religion and spirituality	27	1.5%
Foreign news commentary	103	5.7%
Health, Lifestyle and Sanitation	87	4.8%
Total	1,796	100%

The table above details the frequencies of issue categories that received attention on the three media platforms throughout the study. As per the findings above, the issue category '*Entertainment and celebrity scandals*' ranked the highest issue of salience on all three media types, receiving the highest number of items coded during the four time spans with a total of 346 (19.3%) news stories, tweets and Instagram posts. This means that aside from the news websites publishing more stories relating to the '*Entertainment and celebrity scandals*' issue category, the issue category also received attention on Twitter and Instagram within the period, giving a clue to the fact that one out

of every five of the total number of items collected was likely to be an entertainment-related story.

Following the

'Entertainment and celebrity scandals' issue category is the *'Electricity (Dumsor) and transport'* category.

Ghana's brief energy problems during the period under study which resulted in some few days of intermittent blackouts coupled with accidents in the month of March may have given this issue category a high level of salience.

Another issue category that was given salience was *'Politics, corruption and governance'* (10.9%).

News stories and posts about corruption and politics may usually receive a high level of attention because of the media and citizens' role in safeguarding democracy, ensuring transparency in political processes and their continuous fight to lower corruption in their societies (Camaj, 2013; Besley and Burgess, 2001). As indicated in table 2.0 above, the issue category on *'Religion and spirituality'* received the least attention on all three media combined during the study period. The issue category counted only 27 items representing 1.5% of the data.

However, the issue categories of *'Social issues'*, *'Education, youth and technology'*, *'Local and foreign sports news'*, *'Security, kidnapping and crime'* also received a relatively fair amount of salience with all of them competing with one another in the percentage of 8.3 per cent, 8.2 per cent, 8.1 per cent and 8 per cent, in that order. Receiving a little more salience above these issue categories was *'Economy, Cedi depreciation and Employment'*.

5.1.2 Comparing Media Agendas Between Twitter, Instagram and Online News Websites

Table 3.0 Comparing the Rank Order of Issue Categories Among Three Media Agendas Over the Four Time Spans

Issue Category	Twitter					Instagram					News Websites				
	T1	T2	T3	T4	TTL	T1	T2	T3	T4	TTL	T1	T2	T3	T4	TTL
<i>Elections, electoral violence and vigilantism</i>	1	4	4	18	27	0	1	0	1	2	7	14	5	6	32
<i>Politics, corruption and governance</i>	3	13	56	12	84	1	1	3	11	16	14	45	19	15	93
<i>Economy/Cedi Depreciation/ Employment</i>	12	34	18	2	66	4	2	5	3	14	21	41	15	19	96
<i>Security, kidnapping and crime</i>	16	15	12	13	56	0	4	3	0	7	23	36	15	7	81
<i>Electricity (Dumsor) and transport</i>	20	31	105	3	159	0	3	5	1	9	2	20	21	5	48
<i>Entertainment/ celebrity scandals</i>	5	24	30	123	182	7	5	23	17	52	18	52	24	18	112
<i>Education, youth and technology</i>	3	15	22	4	44	9	1	1	0	11	17	37	17	22	93
<i>Local and foreign sports news</i>	0	47	8	24	79	0	1	1	0	2	12	29	13	11	65
<i>Social issues</i>	12	12	22	2	48	15	0	4	2	21	19	32	22	7	80
<i>Religion and spirituality</i>	0	7	0	0	7	0	0	1	1	2	3	10	4	1	18
<i>Foreign news commentary</i>	3	15	7	1	26	0	4	1	0	5	23	30	9	10	72
<i>Health, Lifestyle and Sanitation</i>	0	11	16	0	27	0	1	2	2	5	6	20	14	15	55
TOTAL	75	228	300	202	805	36	23	49	35	146	165	366	178	136	845

NOTE: T1=Time 1, T2=Time 2, T3=Time 3, T4=Time 4. TTL=TOTAL

Table 3.0 compares the frequency of issue categories on the three media across the four time spans.

Aside from 'Entertainment and celebrity Scandals', the issue category which received a high

amount of attention across all the media under study over time, '*Economy/Cedi Depreciation/ Employment*' also received a consistent frequency on all media across time except for Time 4 on Twitter and Time 3 in the online news websites. Relative to other issue categories on Instagram, the '*Economy/Cedi Depreciation/ Employment*' category received a fair amount of attention on Instagram. On the other hand, while the '*Electricity (Dumsor) and transport*' saw lower frequencies on Instagram and the online news websites, the category received a massive amount of mentions on Twitter, contributing about 74 per cent to the total number of items coded under that category on all three media platforms combined. Additionally, while an issue category like '*Local and foreign sports*' received a relatively fair amount on Twitter and the online news websites, the category received limited attention on Instagram.

Overall, the frequency of the '*Religion and spirituality*' category was very limited across all media, scoring 1.5% on all three media combined.

Table 4.0 Comparing the Frequency of Agendas Between Online News Websites and Twitter

Over Time

Issue Categories	News Websites					Twitter				
	T1	T2	T3	T4	Total	T1	T2	T3	T4	Total
<i>Elections, electoral violence and vigilantism</i>	7	14	5	6	32	1	4	4	18	27
<i>Politics, corruption and governance</i>	14	45	19	15	93	3	13	56	12	84
<i>Economy, Cedi depreciation and Employment</i>	21	41	15	19	96	12	34	18	2	66
<i>Security, kidnapping and crime</i>	23	36	15	7	81	16	15	12	13	56
<i>Electricity (Dumsor) and transport</i>	2	20	21	5	48	20	31	105	3	159
<i>Entertainment and celebrity scandals</i>	18	52	24	18	112	5	24	30	123	182
<i>Education, youth and technology</i>	17	37	17	22	93	3	15	22	4	44
<i>Local and foreign sports news</i>	12	29	13	11	65	0	47	8	24	79
<i>Social issues</i>	19	32	22	7	80	12	12	22	2	48
<i>Religion and spirituality</i>	3	10	4	1	18	0	7	0	0	7
<i>Foreign news commentary</i>	23	30	9	10	72	3	15	7	1	26
<i>Health, Lifestyle and Sanitation</i>	6	20	14	15	55	0	11	16	0	27
Total	165	366	178	136	845	75	228	300	202	805

Table 4.0 above presents the distribution of items under the various issue categories of the sampled news websites and Twitter across time. The total number of issues recorded on the online news websites was slightly higher than the total frequency of issues recorded by Twitter across the entire study period. The findings show that the time span played a role in what the two platforms place salience on. For instance, while the news websites were concerned with issues relating to ‘*Security, kidnapping and crime*’, ‘*Foreign news commentary*’ and ‘*Economy, Cedi depreciation and Employment*’ in Time 1, Twitter was more focused on issues that were related to ‘*Electricity (Dumsor) and transport*’, ‘*Security, kidnapping and crime*’ and ‘*Social issues*’.

Across the entire period, four issues categories that received coverage on the online news websites were stories related to ‘*Entertainment and celebrity scandals*’, ‘*Education, youth and technology*’, ‘*Economy,*

Cedi depreciation and employment’ and *Politics, corruption and governance*’ while the attention on Twitter over the period was focused on *Entertainment and celebrity scandals*, *Electricity (Dumsor) and transport*, *Politics, corruption and governance*’ and *Local and foreign sports news*’.

In some of the time spans, Twitter and the online news media agreed on the amount of salience they devoted to certain issue categories. For instance, in Time 3, the two media shared similar amounts of salience on issues relating to *Entertainment and celebrity scandals*’ and *Electricity (Dumsor) and transport*’. These two issues were part of the top three most frequent issues that received attention on the two media. In the same time span, the online news media devoted a good amount of coverage to issues that involved *Social issues*’ while Twitter’s attention was more focused towards issues in *Electricity (Dumsor) and transport*’. The amount of posts relating to issues in *Electricity (Dumsor) and transport*’ that were coded on Twitter in Time 3 represented 50 per cent of the total number of posts under the *Electricity (Dumsor) and transport*’ category in the two media across the entire period.

Additionally, over the entire period, there was minimal coverage of issues related to the *Religion and Spirituality*’ on Twitter and the online news websites although the frequency on the online news websites was better than that of Twitter.

Table 5.0 Comparing the Frequency of Agendas Between Online News Websites and Instagram Over Time

Issue Categories	News Websites					Instagram				
	T1	T2	T3	T4	Total	T1	T2	T3	T4	Total
<i>Elections, electoral violence and vigilantism</i>	7	14	5	6	32	0	1	0	1	2
<i>Politics, corruption and governance</i>	14	45	19	15	93	1	1	3	11	16
<i>Economy, Cedi depreciation and Employment</i>	21	41	15	19	96	4	2	5	3	14
<i>Security, kidnapping and crime</i>	23	36	15	7	81	0	4	3	0	7
<i>Electricity (Dumsor) and transport</i>	2	20	21	5	48	0	3	5	1	9
<i>Entertainment and celebrity scandals</i>	18	52	24	18	112	7	5	23	17	52
<i>Education, youth and technology</i>	17	37	17	22	93	9	1	1	0	11
<i>Local and foreign sports news</i>	12	29	13	11	65	0	1	1	0	2
<i>Social issues</i>	19	32	22	7	80	15	0	4	2	21
<i>Religion and spirituality</i>	3	10	4	1	18	0	0	1	1	2
<i>Foreign news commentary</i>	23	30	9	10	72	0	4	1	0	5
<i>Health, Lifestyle and Sanitation</i>	6	20	14	15	55	0	1	2	2	5
Total	165	366	178	136	845	36	23	49	38	146

Table 5.0 above compares the frequency of issues on the twelve (12) issue categories between Instagram and news websites. Between the two media, the total frequency of coverage on the news websites (N=845) was far above the total number of posts on Instagram (146) over the period. Simply, the total number of posts across time on Instagram represents about 17.3 per cent of the total number of issues on the online news websites.

As Table 5 indicates, the most frequent issue in Time 1 within the two media was ‘*Social issues*’, but ‘*Education, youth and technology*’, ‘*Entertainment and celebrity scandals*’ and ‘*Economy, Cedi depreciation and Employment*’ appeared to also be major issues in Time 1.

Additionally, the number of posts relating to the various issue categories on Instagram across the four time spans were relatively lower than the frequency of issues on the news websites. However,

the ‘*Social issues*’ category received a fair amount of attention on Instagram. In contrast however, the same ‘*Social issues*’ category received no mention under some of the time spans on Instagram during the study period.

5.1.2 Comparing Twitter and Instagram Agenda

Table 6.0 Frequency of Issue Categories on Twitter Over the Period

Issue Categories	Twitter				TOTAL
	T1	T2	T3	T4	
<i>Elections, electoral violence and vigilantism</i>	1	4	4	18	27
<i>Politics, corruption and governance</i>	3	13	56	12	84
<i>Economy, Cedi depreciation and Employment</i>	12	23	18	1	51
<i>Security, kidnapping and crime</i>	16	15	12	13	56
<i>Electricity (Dumsor) and transport</i>	20	31	105	3	159
<i>Entertainment and celebrity scandals</i>	5	24	30	123	182
<i>Education, youth and technology</i>	3	15	22	4	44
<i>Local and foreign sports news</i>	0	47	8	24	79
<i>Social issues</i>	12	12	22	2	48
<i>Religion and spirituality</i>	0	7	0	0	7
<i>Foreign news commentary</i>	3	15	7	1	26
<i>Health, Lifestyle and Sanitation</i>	0	11	16	0	27
Total	75	228	300	202	805

The total number of items collected on Twitter was 805. The category ‘*Entertainment and celebrity scandals*’ received the highest amount of attention on Twitter. Tweets on this category exponentially increased from 30 in Time 3 to 123 in Time 4.

Tweets about ‘*Electricity (Dumsor) and transport*’ were frequently found in Time 1. This was followed by ‘*Security, kidnapping and crime*’ and ‘*Social issues*’ as they were also frequently

tweeted about in Time 1. There were no tweets about *'Religion and spirituality'*, *'Local and foreign sports news'* and *'Health, Lifestyle and Sanitation'* on Twitter in Time 1. However, as shown in tabl6.0 above, the number of tweets on *'Local and foreign sports news'* increased from 0 to 47 in Time 2.

Table 7.0 Frequency of Issue Categories on Instagram Over the Period

Issue Categories	Instagram				TOTAL
	T1	T2	T3	T4	
<i>Elections, electoral violence and vigilantism</i>	0	1	0	1	2
<i>Politics, corruption and governance</i>	1	1	3	11	16
<i>Economy, Cedi depreciation and Employment</i>	4	2	5	3	14
<i>Security, kidnapping and crime</i>	0	4	3	0	7
<i>Electricity (Dumsor) and transport</i>	0	3	5	1	9
<i>Entertainment and celebrity scandals</i>	7	5	23	17	52
<i>Education, youth and technology</i>	9	1	1	0	11
<i>Local and foreign sports news</i>	0	1	1	0	2
<i>Social issues</i>	15	0	4	2	21
<i>Religion and spirituality</i>	0	0	1	1	2
<i>Foreign news commentary</i>	0	4	1	0	5
<i>Health, Lifestyle and Sanitation</i>	0	1	2	2	5
Total	36	23	49	35	146

From the findings spread in Table 7.0, the issue categories *'Entertainment and celebrity scandals'*, *'Social issues'* and *'Politics, corruption and governance'* were among the top three most frequent issues that received attention on Instagram, making up about six(6) per cent of the total frequency of items coded on Instagram. Throughout the time frame, the issue category *'Entertainment and celebrity scandals'* received a relatively high amount of frequency (**36%**). Of all the four time

spans, Time 3, which was the period between 25th to 27th March, received the highest amount of issues.

Additionally, the frequency of issues across the four time spans did not change very much on Instagram. However, the category *'Entertainment and celebrity scandals'* received a boost in frequency in Time 3 and Time 4 while the *'Social issues'* category also received relatively higher amount of salience in Time 1 on Instagram. During the entire period, issues concerning categories *'Elections, electoral violence and vigilantism'*, *'Local and foreign sports news'* and *'Religion and spirituality'* received little to no attention. They also recorded no mention under some of the time spans.

Table 8.0 Comparing the Frequency of Agendas Between Twitter and Instagram Over Time

Issue Categories	Twitter					Instagram				
	T1	T2	T3	T4	Total	T1	T2	T3	T4	Total
<i>Elections, electoral violence and vigilantism</i>	1	4	4	18	27	0	1	0	1	2
<i>Politics, corruption and governance</i>	3	13	56	12	84	1	1	3	11	16
<i>Economy, Cedi depreciation and Employment</i>	12	34	18	2	66	4	2	5	3	14
<i>Security, kidnapping and crime</i>	16	15	12	13	56	0	4	3	0	7
<i>Electricity (Dumsor) and transport</i>	20	31	105	3	159	0	3	5	1	9
<i>Entertainment and celebrity scandals</i>	5	24	30	123	182	7	5	23	17	52
<i>Education, youth and technology</i>	3	15	22	4	44	9	1	1	0	11
<i>Local and foreign sports news</i>	0	47	8	24	79	0	1	1	0	2
<i>Social issues</i>	12	12	22	2	48	15	0	4	2	21
<i>Religion and spirituality</i>	0	7	0	0	7	0	0	1	1	2
<i>Foreign news commentary</i>	3	15	7	1	26	0	4	1	0	5
<i>Health, Lifestyle and Sanitation</i>	0	11	16	0	27	0	1	2	2	5
Total	75	228	300	202	805	36	23	49	38	146

Table 8.0 is a spread of the total number of stories that were coded under the 12 issue categories on Twitter and Instagram during the period. Both Twitter and Instagram recorded their highest number of posts in in Time 3. *'Entertainment and celebrity scandals'*, *'Electricity (Dumsor) and transport'*, *'Politics, corruption and governance'*, *'Local and foreign sports news'* and *'Economy, Cedi depreciation and Employment'* were the top five issue categories that received a lot of mentions on both Twitter and Instagram. Over the entire period, incidents related to *'Entertainment and celebrity scandals'*, *'Elections, electoral violence and vigilantism'* and *'Local and foreign sports news'* were among the top issues that received attention on Twitter. However, there was slight variation in the type of issues that received salience on Instagram. Issue categories that ranked as top three on Instagram's agenda were *'Entertainment and celebrity scandals'*, *'Social issues'* and *'Politics, corruption and governance'* which indicates that the two social media platforms, Twitter and Instagram, did not share in the same amount of attention they devote to certain issues.

The table further suggests that, while Twitter was concerned with issue categories like *'Elections, electoral violence and vigilantism'* and *'Local and foreign sports news'*, they received close to no mention on Instagram. On a rather significant level, *'Social issues'* and *'Politics, corruption and governance'* received high salience on Instagram, aside from the leading issue category, *'Entertainment and celebrity scandals'*.

5.1.2 Online News Media Agenda

Table 9.0 Frequency Distribution of Issues Categories of News Websites Across Time

Issue Categories	Online Websites				
	T1	T2	T3	T4	Total
<i>Elections, electoral violence and vigilantism</i>	7	14	5	6	32 (3.8%)
<i>Politics, corruption and governance</i>	14	45	19	15	93 (11%)
<i>Economy, Cedi depreciation and Employment</i>	21	41	15	19	96 (11.4%)
<i>Security, kidnapping and crime</i>	23	36	15	7	81 (10%)
<i>Electricity (Dumsor) and transport</i>	2	20	21	5	48 (6%)
<i>Entertainment and celebrity scandals</i>	18	52	24	18	112 (13%)
<i>Education, youth and technology</i>	17	37	17	22	93 (11%)
<i>Local and foreign sports news</i>	12	29	13	11	65 (7.7%)
<i>Social issues</i>	19	32	22	7	80 (9.5%)
<i>Religion and spirituality</i>	3	10	4	1	18 (2.1%)
<i>Foreign news commentary</i>	23	30	9	10	72 (8.5%)
<i>Health, Lifestyle and Sanitation</i>	6	20	14	15	55 (6.5%)
Total	165	366	178	136	845 (100%)

Table 9.0 is a spread of the frequencies of the various issue agendas on the five online news websites across the four various time spans. Of the four different time spans, Time 2 (**21st - 23rd March**) received the highest number of items coded, representing 43.3 per cent of the total items for news websites across the study period. The news coverage pattern of the online news websites over the period was dominated by issues in ‘*Entertainment and celebrity scandals*’, ‘*Economy, Cedi depreciation and Employment*’, ‘*Politics, corruption and governance*’ and ‘*Education, youth and technology*’. Issues in ‘*Elections, electoral violence and vigilantism*’ and ‘*Religion and spirituality*’ received limited coverage over the period.

5. 1.3 Results of Cross-Lagged Correlation Analyses

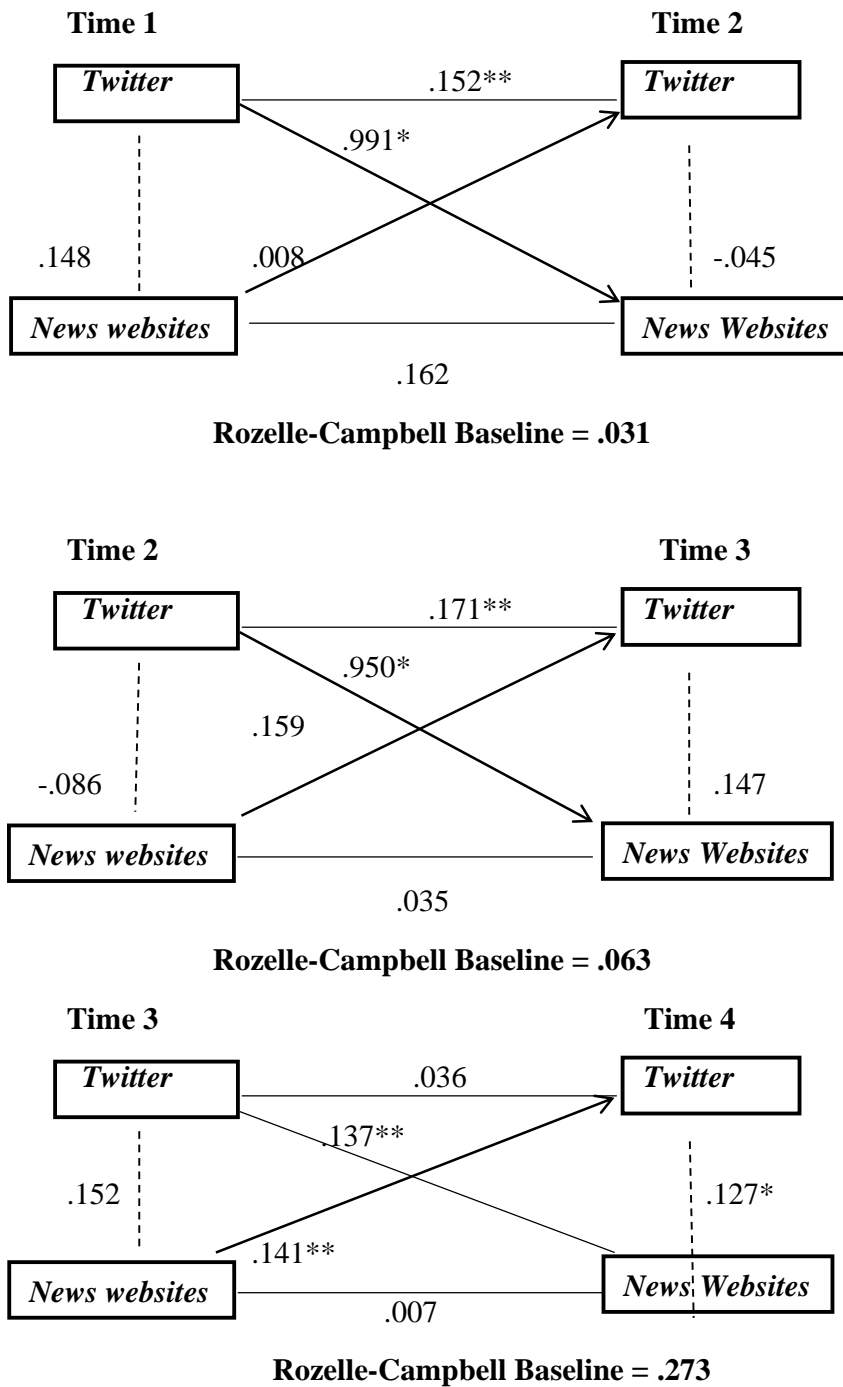

Figure 2 Cross-lagged correlations of issue agendas between **Twitter** and the selected **news websites** across the various time spans. (*Correlation is significant at the 0.05 & 0.01 level {All 2-tailed}).

RQ3 of this study sought to investigate whether Twitter and Instagram's agenda had an influence on online media agenda in Ghana. As shown in Figure 2, the study sought to answer this question by using Pearson's correlations to find the relation between Twitter and the news websites. It also did similar for Instagram and the news websites (See Figure 3. Below). The results suggest that there were significant correlations in all the time spans. The correlation coefficient between Twitter at Time 1 and the news websites at Time 2 ($r=.951, p<.01$) showed a very strong influence of Twitter whereas it showed a rather weak correlation of the reverse, that is between the news websites at Time 1 and Twitter at Time 2 ($r=.008, p<.01$). Therefore, because the cross-correlation between Twitter at Time 1 and the news websites at Time 2 exceed the Rozelle-Campbell baseline and the autocorrelation of the news websites (referred in formula as medium Y) with the opposite cross-correlation between Time 2 of Twitter and Time 1 of the news websites, there is a clear evidence of intermedia agenda-setting of Twitter and the news websites between Time 1 and Time 2.

Between Time 2 and Time 3, there was evidence of intermedia agenda-setting influence of Twitter on the News Websites with a very significant correlation ($r=.950^*, p<.01$). The crosslagged correlation of Twitter at Time 2 and the News Websites at Time 3 was above the RozelleCampbell baseline of .063, the autocorrelation of the News Websites at Time 2 and Time 3 and the cross-lagged correlation of the News Websites at Time 2 and Twitter at Time 3. Therefore, this suggests a clear intermedia agenda-setting effect between the two media within these time spans except that the influence from the News Websites at Time 2 to Twitter at Time 3 was very weak with a correlation of .159 ($r= .159, p<.01$). Even though there was a relatively weak correlation coefficient between the News Websites at Time 2 and Twitter at Time 3 suggesting that the influence of the News Websites on Twitter was very weak, the findings point to a twoway

relationship between Twitter and the News Websites on the salience of issues between Time 2 and Time 3.

However, there was no evidence of an intermedia agenda-setting influence between Twitter and the News Websites at Time 3 and Time 4. This was because the cross-lagged correlation between Twitter at Time 3 and the News Websites at Time 4 ($r=.137^{**}$, $p<.01$) did not exceed the Rozelle-Campbell baseline ($RC=+.273$). Although the two cross-lagged correlation coefficients between Twitter at Time 3 and the News Websites at Time 4 ($r=.137^{**}$, $p<.01$) and the News Websites at Time 3 and Twitter at Time 4 ($r=.141^{**}$, $p<.01$) were both weak, the News Websites tended to have a slightly stronger influence on Twitter although it was insignificant to cause Twitter's agenda to change entirely. Therefore, the general observation was that Twitter had a much stronger influence on the News Websites. At the point where the relationship seemed reciprocal, the influence of the News Websites on Twitter was weak.

The figure below (Figure 3.) also presents the cross-lagged correlations between Instagram and the News Websites across time. Generally, there was not a major significant intermedia agenda-setting between Instagram and the news websites. However, even though there was not a clear evidence of intermedia agenda-setting in any of the time spans 4 as shown in figure 2, the News Websites at Time 3 seemed to have had a little influence on Instagram at Time 4 with a weak correlation of ($r=.164^*$, $p<.01$). It cannot be concluded that there was an intermedia agenda-setting in this time span because it did not meet the criteria for a conclusion to be drawn which is that the cross-correlation between the Instagram at Time 3 and the News Websites at Time 4 should exceed the Rozelle-Campbell baseline and the auto-correlation of the News Websites at 3 and Time 4.

Additionally, the cross-correlation between the News Websites at Time 3 and Instagram at Time 4 should also have been lower than the Rozelle-Campbell baseline.

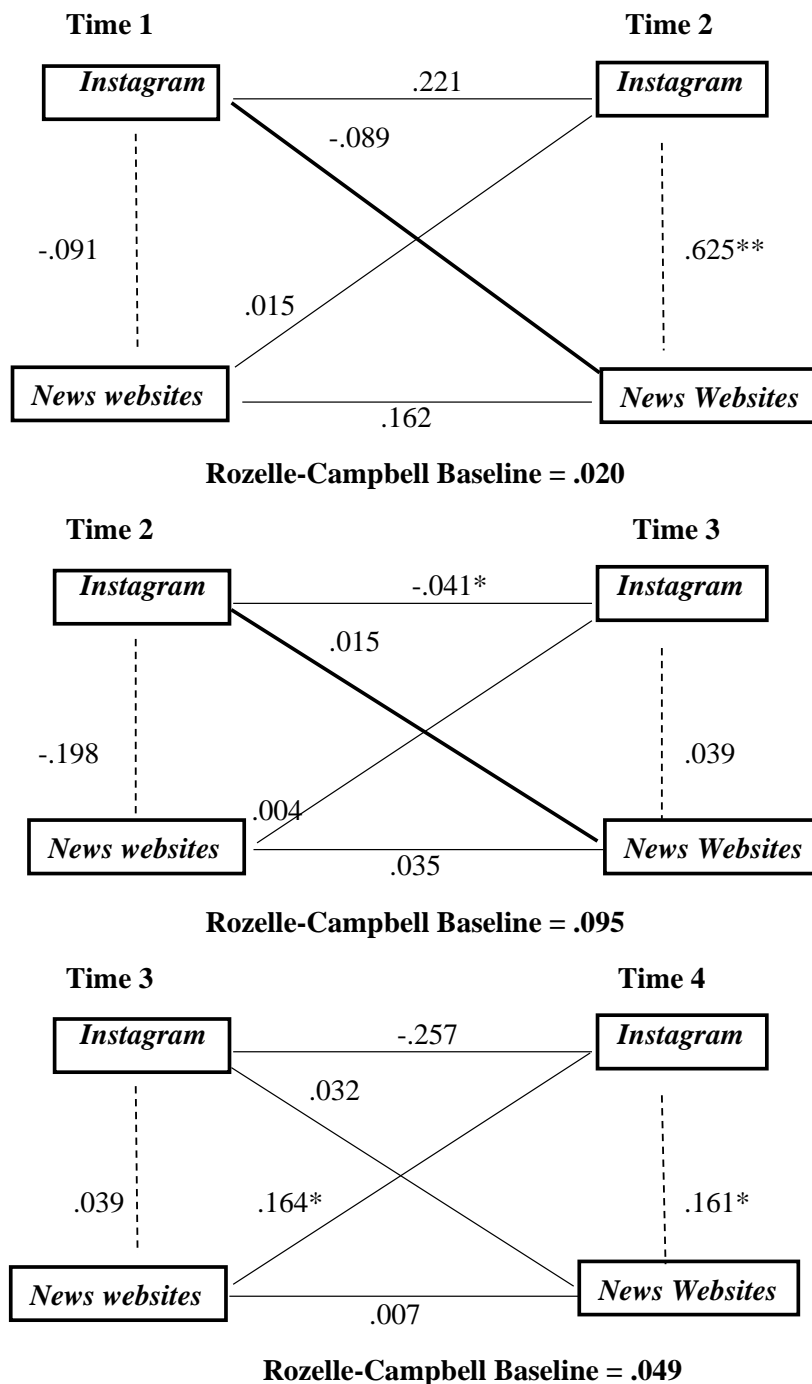

Figure 3. Cross-lagged correlations of issue agendas between Instagram and the selected News Websites across the various time spans. (*Correlation is significant at the 0.05 & 0.01 level {All 2-tailed}).

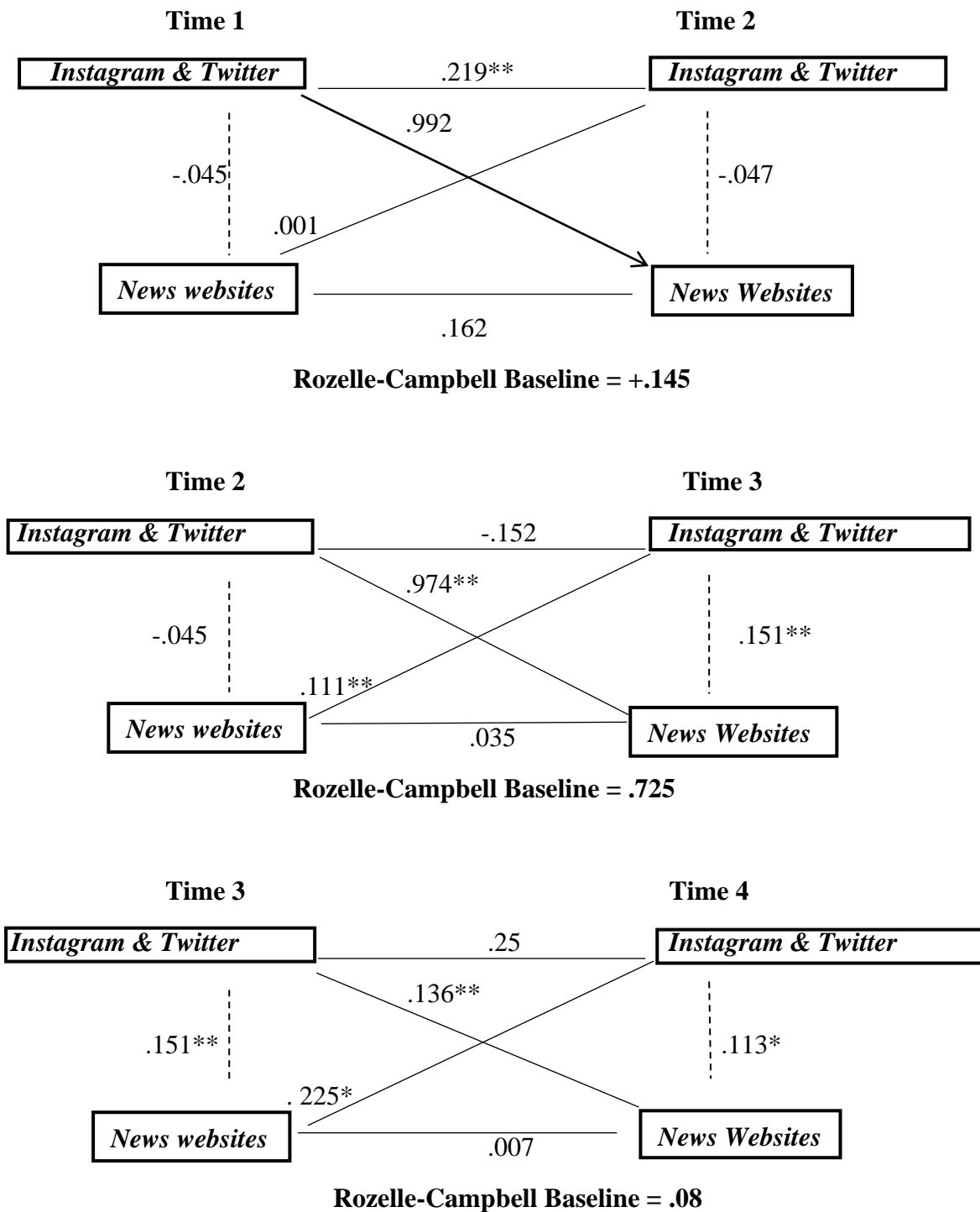

Figure 4. Cross-lagged correlations of issue agendas between the two social media (Instagram and Twitter) and the selected News Websites across the various time spans. (*Correlation is significant at the 0.05 & 0.01 level {All 2-tailed}).

After testing the intermedia agenda setting influence between the two social media (Twitter and Instagram) separately, there was the need to further measure the intermedia agenda-setting influences between the two social media platforms put together and the News Websites. This helped to understand the force of different social media put together. Therefore, additional cross-lag correlations were performed to test whether the strength of the intermedia agenda-setting capabilities of the social media platforms will change if they were together. For the sake of clarity, this part of the findings will refer to Instagram and Twitter as 'social media'.

Figure 4 above presents the outcome of that. As indicated below, between Time 1 of social media and Time 2 of the News Websites, social media had a very strong influence on the news websites with a correlation of $r=.992$, $p<.01$ and exceeded the autocorrelation of the News Websites. It also exceeded the baseline of **+.145**. Even though the cross-correlation ($r=.001$, $p<.01$) of the News Websites at Time 3 and social media at Time 4 was below the baseline, the figure was too insignificant to establish an intermedia agenda-setting influence. It can be maybe suggested therefore that there was intermedia agenda-setting but the News Websites had a very weak influence on social media.

Between Time 2 and Time 3, there was a clear evidence of intermedia agenda-setting as the cross-lagged panel satisfied all the conditions for an intermedia agenda-setting to take place. Within this time span, the News Websites had a relatively stronger influence on social media as compared to Time 1 and Time 2.

The only conclusion that could be made about the last cross-lagged panel between Time 3 and Time 4 was that, while there was no clear evidence of intermedia agenda-setting, The News Websites had a stronger influence on social media with a coefficient of $r=.225^*$ $p<.05$. The

RQ4 sought to analyze how intermedia agenda-setting occurred between Twitter and Instagram i. Figure 4 above represents panels of cross-correlations between Twitter and Instagram across Time.

It was observed that apart from Time 1 and Time 2 where there was a clear evidence of intermedia agenda-setting, there was no other proof of a clear intermedia setting influence in any of the panels. However, both Twitter and Instagram had a very high influence on each other in Time 2 and Time 3. Although this happened, there could not be a conclusion that a clear intermedia agenda-setting occurred because the cross-correlation coefficient ($r=.730^{**}$, $p<.01$) exceeded the Rozelle-Campbell baseline ($r= .042$). That is contrary to the conditions under which a clear intermedia agenda-setting can occur within any two time periods. However, the cross-correlation coefficients showed that there was a stronger two-way relationship between Instagram and Twitter at Time 2 and Time 3.

Between Time 3 and Time 4, the cross-lagged coefficients were all negative. This points to the conclusion that the two social media platforms were all concerned with different issues within that time span.

Additionally, it is seen that most of the correlations from Twitter to Twitter and Instagram to Instagram from one particular time span to another were not strong enough. This suggests that, at every point in time, both Twitter and Instagram were concerned with specific issue agendas. The conclusion, therefore, is that, between Twitter and Instagram, there can sometimes be a shared agenda depending on the period or issue. Also, there are periods that each of them was concerned with specific issues which, may be suggested as ephemeral sometimes.

5.2 PRESENTATION OF QUALITATIVE FINDINGS

To support the findings of the quantitative data, this study added a qualitative method which involved taking a closer look at the top five ranking issue categories and topics among the three media types to find out why they ranked as such. Additionally, it also allowed for an in-depth semi structured interview of editors of two of the selected online news websites to give more depth to the quantitative findings as well as understand Twitter and Instagram's position in the news production processes of the online media.

5.2.1 A Look at the Top Five Issue Categories Across the Three Media

This study sought to investigate the top five ranking issue categories that were given the greatest amount of attention over the study period. The idea was to find topical issues under those issue categories and understand why they dominated the issue categories. Additionally, the aim was to explore whether the identified issues had the same frequencies across the three media and also understand if the frequency of issues on one media influenced other media.

As indicated in the frequency distribution table (See Table 10.0 below) the following issue categories received the highest amount of attention across media: *'Entertainment and celebrity scandals'*, *'Electricity (Dumsor) and transport'*, *'Politics, corruption and governance'*, *'Social issues'* and *'Education, youth and technology'*. The combined percentage of the five categories was 60.1 per cent. The categories have been listed in Table 10.0 below. The figures in the brackets represent their share of coverage in percentage. For the purposes of this analysis, news stories, tweets and Instagram posts will be termed as topics.

Table 10.0 Top 5 Issue Categories on Twitter, Instagram and the news websites (Share of coverage in per cent)

Issue Categories from Twitter, Instagram and News Websites
1. Politics, corruption and governance (10.7)
2. Economy, Cedi depreciation and Employment (9.8)
3. Electricity (Dumsor) and transport (12)
4. Entertainment and celebrity scandals (19.3)
5. Social issues (8.3)

As shown in Table. 10.0, Entertainment and celebrity scandals remained the most frequent issue that received attention on the three media platforms combined. Topics that dominated the category were news stories about *the 3Music Awards*, *the Vodafone Ghana Music Awards* and posts about *Game of Thrones*. While the news stories from the news websites highlighted various nominees for the categories of the awards, performances expected and the main event schedules, most of the tweets and the Instagram posts sampled were concerned with particular issues concerning the awards. An example of such issues was the artiste of the year category and which artiste deserved to win it. As a result of this, they shared posts from the online news websites that had anything to do with the awards. Among these three topics, *Game of thrones* was the issue on social media that influenced online media agenda as they began to publish stories related to fans' expectation of the television show. Most of the stories used tweets and Instagram posts as evidence. Aside from these, another major issue that received enormous attention was Manifest's appearance on the Tim Westwood Show where he did some freestyle rap. Manifest is a Ghanaian musician who has been seen as a competition to other rappers in Ghana, therefore when a video of him on the show emerged, it took over Twitter and Instagram with his fans tweeting and posting videos of the show on their timelines. The frequency of the tweets must have caught the attention of the online media

as news stories about him with videos and comments from social media emerged later on some of the news websites.

The second issue category was '*Electricity (Dumsor) and transport*'. During the study period, there were some power distribution issues in Ghana's electricity supply. The company in charge of electricity distribution in the country, Power Distribution Services (PDS) announced that there will be 12-days of load-shedding known in the local parlance as 'Dumsor'. The load shedding was as a result of the shutdown of Atuabo Gas Processing Plant for mandatory maintenance. This issue received more attention on Twitter than on Instagram and the online news websites. On

Twitter, for instance, there were hashtags like #DumsorIsBack. The Electricity Company of Ghana (ECG) and the Power Distribution Services (PDS) were mentioned in most of the tweets. However, some of the tweets sampled were mostly links to stories that had been published by the online media which suggested that the online media had an influence on social media regarding this issue.

There were also some road accidents within the study period that received attention on all the three media. Topical among them was an accident at Kintampo in the Brong Ahafo Region of Ghana that claimed the lives of 67 people. The incident received a very high amount of attention on Twitter but most of the tweets were stories that had been published by online news websites. According to the data gathered for this study, Twitter users mostly shared the links to the stories with their personal comments or reactions. For instance, a Twitter user tweeted this referring to a link that had already been shared:

@Tumtum_Black: Accidents have made too many wives widows and husbands widowers. Children have been orphaned. These things are too normal in Ghana, that is not how it should be. Today, after such a national tragedy, we need to have a serious conversation on road safety #Kintampo (March 22, 2019).

In the online media, however, news stories revolved around the number of lives the accident claimed, the bad nature of roads in Ghana and issues surrounding the mass burial of the victims.

There were also news stories on discussions in Parliament about regulating night driving in Ghana.

As data gathered for this study suggested, this story received a very high amount of attention on Twitter but the source of the Twitter discussion was the online media. The attention given to that same issue on Instagram was relatively low. Another issue that gained attention under the

'Electricity (Dumsor) and transport' category was the legalization of 'Okada' (Commercial motorbikes). Of the two social media networks under study, the attention given to this story was massive. The issue became a talking point on Twitter after a group of commercial motor riders appealed to the government to legalize the 'Okada' business so that it will also be another avenue of job creation while reducing the heavy traffic in the city. The numerous tweets about 'Okada' issue was with Twitter users sharing experiences and photos of times they had used 'Okada'. The salience attached to this topic on Twitter was high. Because of that, the topic equally received a good amount of coverage in the online media as they explored different angles such as existing laws on the issue and parliamentary discussions which were additionally shared by social media users.

Following this issue category was *'Politics, corruption and governance'*. According to the coding instructions of this study, news articles, tweets and Instagram posts relating to corruption, local governance, misappropriation of funds, parliament and government's activities were coded under this category. Of the issues coded, the passage of the Right to Information (RTI) Bill, the president's intention to make French a second language in Ghana and support for Martin Amidu, Ghana's Special Prosecutor, to fight corruption became the topical issues within the period. Within

the data collection of the study specifically March 26, 2019, the RTI Bill was passed by Ghana's Parliament. The bill had been in parliament since 2010. Hashtags and tweets like #RTIBill and *'RTI Bill is here'* dominated Twitter discussions. Much of this story was not seen on Instagram. In the online media data gathered, news coverage of the RTI Bill revolved around the advantages and disadvantages of the bill and what the future looks like for the Ghanaian media regarding the passage of the bill into law. Another issue that received quite an amount of coverage under this issue category was corruption. Whereas the Twitter and Instagram data was more of memes about Martin Amidu, the Special Prosecutor of Ghana, and how he is delaying on his promise to go after corrupt government officials, news stories in the online media were focused on government's call for public support for the Special Prosecutor to do his job.

The fourth of the top five ranked issue categories was the *'Economy, Cedi Depreciation and Employment'* issue category. Issues relating to the cedi's depreciation and the finance minister's constant reminder that the cedi will remain stable in no time coupled with his constant statements that the economy is back in shape, were some of the major issues that were coded under the category. The data collection period was done at a time where the cedi experienced depreciation against other foreign currencies. Additionally, the data collection period also took place around a period where Ghana left the International Monetary Fund's (IMF) Extended Credit Facility (ECF) programme. Therefore, issues surrounding Ghana's exit dominated Twitter discussions but a majority of the tweets also were still focused on the depreciation of the cedi as Twitter users and a few Instagram users shared screenshots of the cedi-dollar exchange rate. While Twitter users and Instagram users were posting screenshots of the exchange rate, online media's attention was focused on views from experts and politicians.

'*Social issues*' was the last issue category that received attention on all the three media combined. With this particular issue category, the attention that was given to it on Instagram was relatively higher than all the other issue categories except for the issue category of '*Entertainment and Celebrity Scandals*'. News stories, tweets and posts related to cervical cancer awareness, issues in polygamous marriages, domestic violence and mobile money robbery, were the topical items coded. On Instagram particularly, the discussions revolved more around cervical cancer and domestic violence which were almost ignored by the online media during the study period. Although it was only heightened at Time 1 and did not have the same frequency throughout the four different time spans, it later gained more attention on Twitter and the online news websites in subsequent time spans. However, Instagram and Twitter were ahead of mainstream media for stories that emerged under this particular issue category. The tweets and posts on this issue were mostly in pictures.

5.3 Results of In-depth Interviews

This part of the study presents the results of the in-depth semi-structured interviews with editors of two of the selected online news websites to support and give further insights into the quantitative findings. The two editors that were interviewed were from Yen.com.gh and Ghananewsagency.org. The following codes were assigned to the two respondents: **R1Y** (Respondent 1, Yen.com.gh) and **R2GNA** (Respondent 2, Ghananewsagency.org). The choice of the editors were partly due to the content they produced. While GNA focused on more serious issues, Yen.com.gh reported lighter issues such as entertainment and celebrity issue. This gave a good contrast between the two to understand how the kind of content a news media focused on was likely to impact how they used social media. Only two editors were selected because their answers were used to support the quantitative findings.

After several careful and several readings of the interview transcripts, their responses were used to generate the following themes: Influence of social media agenda on newsroom agenda; social media as a source; social media platforms as tools for verification; social media users as news agents. As a way of providing a deeper understanding of the findings, some peculiar quotes from the respondents have been cited to support the themes generated.

5.3.1 Influence of Social media agenda on online news media agenda

The two editors from the media firms interviewed shared varied views on how the daily agenda on social media like Twitter influences the agenda of the newsroom agenda. Their views suggest that issues that trend on social media platforms affect the daily coverage of the news websites.

For instance, Respondent R1Y states:

Sometimes you have your plans for the next day but you wake up in the morning and you realize there is something trending and then you push aside whatever you have and cash in on what is trending. (R1Y, June 18, 2019)

For a news website like Yen.com.gh, an editor shared the fact that reporters are allowed to monitor social media platforms like Instagram, Twitter and Facebook regularly for leads to stories that they will write in the day. She said:

Let's say you hear a story about Jackie Appiah saying her favourite food is banku. So how do you verify; you go straight to Jackie Appiah's Twitter and Instagram to see if there is any such information there. So, in that case, my media house allows me to make full use of the social media and in fact it has become a norm or a requirement of each and every editor to have social media handles (R1Y, June 18, 2019).

Even though respondent two (**R2GNA**), an editor from the Ghana News Agency admitted to social media's influence on some of their reporting activities, she added that the Ghana News Agency only pay attention to social media trends that are of public interest. The editor said:

Ok so, errhm we don't necessarily say that we are checking social media for news but if an issue is trending on social media and it is of public interest, yes, my news organization will always be interested in following up (R2GNA, June 22, 2019).

However, she added that they had to make sure that they verify it through the proper means before they use it as news. The editor said:

So GNA, one of the things we are very particular about is credibility. We don't want to go out there and say something which we are not sure of. So, most of the time we want to be sure it is credible news before we publish it. So maybe we do not have a technology or something but we always crosscheck (R2GNA, June 22, 2019).

5.3.2 Social Media as a Source

From the interview, all the respondents agreed on social media's role as a new source of news for mainstream media. Apart from the fact that the social media agenda may influence their publishing schedules, they see it as a new source for gathering news especially because most of the people they categorize as newsmakers can be found there. The editor at Yen.com.gh said:

... Basically, social media is our number one source for entertainment news. In this digital age, you know everything, the trend has changed and the whole thing is evolving around digital so, social media is one of our foremost source for news. Why? Because most of the things we write about or the celebrities, in fact they make the news and so for accuracy and easy verification we go straight to their social media handles to see if they are the right source of what is being said about them (R1Y, June 18, 2019).

On the other hand, the online editor from the Ghana News Agency also said:

Social media is very important. In fact, it's crucial to even media development now and not just in Ghana but in the whole of the world. I keep telling people that all of my news now, I look on social media and I get it. In fact, social media gives you everything, video, audio and everything, text. So, it's become a one-stop shop for people looking for information. So, it's very crucial to...., that's where the world is going – internet, social media, online and we can't afford to just be there and not do it (R2GNA, June 22, 2019).

5.3.2 Social Media Users as News Agents

The editors also shared how important social media users are to the modern newsroom. The recurrent idea about social media users gathered in the interviews showed that social media users are not only news sources to reporters but that they have also become like news agents. They are now the main target to share their news to as these news websites operate active Twitter, Instagram, Facebook and other social media pages. For instance, the online editor at the Ghana News Agency indicated:

They are as important as the regular news listeners or whatever. You know, your target is to inform and the people behind the social media walls are tangible human beings who are searching for information so you cannot treat them as unimportant. They are very important. Our end-users, those who surf Ghana News Agency's online link, are very important (R2GNA, June 22, 2019).

While the social media users acted as agents to share news for online media organizations, they also were avenues through which reporters could get news leads and follow-ups to stories they had already done. The comments on stories are likely to influence subsequent reporting.

Sometimes, the editors admitted that they get messages from social media about stories the social media users wanted them to cover. An online editor from Yen.com.gh said:

...so, most of the follow-ups I do are from the comments people leave on some of the stories I do. Meaningful comments. Great ones. Comments that will give me a great follow-up story, and that's what I do (R1Y, June 18, 2019).

Additionally, aside from these dominant themes some of the responses from the editors suggested that social media platforms are gradually serving as verification tools for them. To be able to validate claims of newsmakers reported by other news websites, journalists sometimes resorted to visiting their Twitter, Instagram, Facebook or other social media pages as their first source of verification.

5.4 Chapter Summary

This chapter presented the findings of this study. The findings were presented in two parts. The first part comprised the quantitative aspect where findings were presented with descriptive tables with the necessary explanations. Additionally, to understand intermedia agenda-setting influence among the media sampled, a number of cross-lagged correlation analyses were performed and subsequently explained. The second part comprised of the findings the qualitative aspect of this study which involved a close look at the top five issue categories that appeared in the quantitative data and interviews with two editors of the sampled news websites were also analyzed thematically.

CHAPTER SIX

DISCUSSION OF FINDINGS

6.0 Introduction

The purpose of this study was to investigate the intermedia agenda-setting influence among Twitter, Instagram and online news websites in Ghana. This chapter, therefore, presents an indepth discussion of the findings of this study. The discussions are based on the objectives and questions of the study. To situate the discussions in context and make meaningful claims, the findings are discussed in relation to the theory that underpins this study and also in relation to previous studies. Excerpts from interviews and figures from findings will also be used where necessary.

6.1 Twitter and Instagram Agenda Versus Online News Media Agenda in Ghana

To engage with RQ1 of this study, which aimed to examine the categories of issue agendas that dominate the agendas of Twitter, Instagram and the online media in Ghana, the study used descriptive statistics to measure the frequency of issues that were prevalent in the various issue categories of the three media platforms. After a content analysis was carried out, the findings of the study suggested that even though some peculiar issue categories overlapped in the agendas of Twitter, Instagram and online media, the rank in which they appeared differed completely on each of the platforms. Issue agendas relating to *'Entertainment and celebrity scandal'* however were on top of the agendas of all three media. The frequency of issues on the three media constituted 19.3 per cent of the total data. This is contrary to Brannock Cox's (2014) study which concluded that online news media were more interested in topics such as law and crime, accidents and disasters, politics, economy, governance and foreign events. This shows that online

media, although still focused on ‘conventional’ news categories, are becoming more inclined to other unconventional news such as celebrity scandals and gossip, health and lifestyle. Another deduction from this is that, anecdotal evidence has suggested that online news media has become more of a business venture where owners rely on revenue from advertising to maintain them. The only way to gain more advertising revenue is to get more clicks and eyeballs. To do this, they have to go with trending issues on social media in addition to their regular content in order to get more views which will translate to revenue.

The findings indicated on the other hand that Twitter especially, has an interest in issues relating to politics, corruption, governance, economy, electricity as well as issues related to transportation. This confirms a 2016 conclusion by the *How Africa Tweets report* that argued that Africans on Twitter were more likely to discuss or share regular news topics such as those relating to politics and governance than Twitter users in some parts of the West. Therefore, in contrast with previous studies by Bakan and Melek (2013) that concluded that social media’s attention on conventional issues were likely to follow the news media agenda in epochal events such as elections, natural disasters or anything of national interest, this study also finds that social media platforms like Twitter was still concerned with regular news issues on ‘routine’ news days.

Interestingly, aside from entertainment issues, the ‘Social issues’ category received a relative amount of attention on Instagram. Topics relating to gender, sex and relationships were mostly discussed on Instagram. This shifts from the existent notion that Instagram was used to only share glamorous photos and videos. What this means is that Instagram is gradually joining Twitter in becoming a social discussion platform where people do more than update their pages with photos of what is happening in their lives. This ties in with Towner and Munoz’s (2017)

study that found that political candidates in the 2016 United States Presidential Elections used Instagram to post a lot of their campaign messages in the form of images. The implication to future research is that new social media platforms who operate differently from Twitter and Facebook should be considered in agenda-setting research. Also, reporters can explore Instagram as a new avenue for gathering leads to news stories with angles from the perspectives of the ordinary person.

Also, apart from these findings, the number of social issues that received attention on the two social media platforms suggested that more people were willing to discuss issues relating to sex, gender and relationships on the internet. This finding supports previous research findings by Roberts, Wanta and Wu (2002) who argue that people are likely to discuss issues they consider as sensitive like gender and domestic violence on the internet even when the issues are not receiving attention on other mainstream media.

6.2 Do Twitter and Instagram set their original agenda or just rehash what the Ghanaian online media has set?

In a bid to understand RQ2 of this research, a qualitative content analysis of the top five issue categories that appeared in the data was conducted. The analyses found that Twitter, Instagram and the News Websites usually set their own original agenda. However, this was dependent on the kind of issue agenda and the time period.

Analysis of data gathered showed that Twitter and Instagram mostly set their original agenda with issues relating to *entertainment, celebrity scandals, gender* and sometimes *governance* and *electricity*. As suggested by Rogstad (2016), Twitter gives attention to issues that are overlooked by mainstream media such as news about gender equality and some forms of entertainment news.

She argues that the reason for the contrast in the kind of agenda that social media and online news media might be “that mainstream media are absorbed with day-to-day news, while Twitter is a forum where news is commented on and discussed”.

However, it was evident in the data collection that, most of the conversations about issues on social media started with links to news from online media. Items like that formed about 39 per cent of Twitter and Instagram data gathered. It was also noted that the links came with their own comments from the people who posted them. These comments started most of the vibrant discussions on the two social networking sites. From the interviews analyzed, one of the editors mentioned that even when they post links of news on social media, they follow up on the comments to get other stories. She said:

Yes, so, most of the follow-ups I do are from the comments people leave on some of the stories I do. Meaningful comments. Great ones. Comments that will give me a great follow-up story, and that's what I do.

On Instagram however, screenshots of the headlines were usually posted with captions of the images usually taking the form of summaries or excerpts of what the story was about. In other cases, they were left with personal comments of the Instagram user who tend to share their own opinions on the issues.

It must however be noted that, while previous scholars such as Rogstad (2016) have argued that social media platforms like Twitter were more concerned with media agendas, this study found that in Ghana, there was a variation in the kind of media agenda social media would be interested in. Equally, the online media also had specific issues that they picked from social media aside from issues that fell under the conventional issue categories. For instance, the editors interviewed

said they would choose some specific issues from Twitter and Instagram based on their concept of what is news. Therefore, they chose content with news values such as bizarreness and currency. However, the general conclusion is that whenever online media set an agenda, they rely on social media to make it trend and receive the kind of attention anticipated. In essence, social media would set an agenda on topics that online news reporters may consider not newsworthy until the issues gain so much attention that online media picks it, refines it and throw it back to them for the issues to be rehashed by Twitter and Instagram users. The reason why social media users may usually jump on the online media's refined agenda may be because they see them as a more trusted source. However, during the period of study, it was realized also that on typical days where social media agenda was limited, they focused their attention on online news media's agenda, retweeting, commenting and reposting.

6.3 How much influence does Twitter and Instagram's agenda have over online media agenda in Ghana?

This study also sought to find out the amount of influence Twitter and Instagram agenda have over online media's agenda. Cross-lagged correlations were conducted to measure the influence among all the media sampled. The cross-lagged correlation established that social media—Twitter and Instagram— had an influence on the news websites most of the time. The analyses provided evidence that showed that some of the influences were reciprocal, while others were direct and clear, suggesting that within some time spans, a particular media's agenda clearly predicted the agenda of the other.

Between Twitter and Instagram, Twitter's influence on the News Websites was usually higher except for some time periods in the cross-lagged panels where Instagram also exerted some

influence. The cross-lagged correlations mostly seemed to suggest Twitter's influence on the online media. Compared to the statistics of Twitter users in Ghana which stands at 9.41 per cent as at January 2019, the findings suggest that the “*Twittersphere*” in Ghana has a stronger intermedia agenda-setting capability with its actors whose activities such as tweeting, retweeting and commenting directs reporters' attention to issues on different topics. Their activity, although somehow passive, directs online news editors on the various angles they can use to cover certain issues. In one of the interviews with an online editor at Yen.com.gh, she admitted to how social media trends can influence reporting schedules for the day. She states:

Yes. You know in this our field of journalism you already know. Sometimes you have your plans for the next day but you wake up in the morning and you realize there is something trending and then you push aside whatever you have and cash in on what is trending.

However, there was very weak intermedia agenda-setting between Instagram and the news websites even though there was an occurrence of a slightly higher influence of the news websites between Time 3 and Time 4. The influence wasn't so strong to have affected all the discussions on Instagram at the time. Contrary to this finding is a study by Towner and Munoz (2017) that suggested that the Instagram posts of the 2016 United States presidential elections predicted the issue agenda in newspapers. Even so, they concluded that the posts by Hilary Clinton who was also the presidential for the Democratic Party more readily influenced and predicted mainstream newspaper agenda. A simple explanation to this is that, even though Instagram is in its early stages, it's influence on mainstream media may depend on context and issue.

Also, when the two social media platforms were put together as a single force for the analysis, their influence was stronger on the news websites except for one of the cross-lagged panels where the news websites seemed to have influenced social media agenda slightly between Time

3 and Time 4. The reason for this could be that the news websites in Ghana, however prompt they may be at breaking news, do not run a fulltime 24/7 cycle and so social media networking platforms like Twitter and Instagram who receive engagements or interactions every time overtake them in breaking news. Weimann and Brosius's (2016) study argue that due to the pace at which many social media networking sites like Facebook, Instagram, Twitter and YouTube operate, they may actually have the potential to impact the agenda of traditional news outlets.

Relating this discussion to the original intermedia agenda-setting theory, which stipulates that while the media is busily influencing public agenda, they themselves are also being influenced by the agenda of other media, the study found that Twitter and Instagram are beginning to play the role of regular news media whose activities impact the news selection preferences of online media . As has been argued by Kim, Kim and Zhou (2014), intermedia agenda-setting is seeing new dynamics, especially with the diffusion of new and social media. The advancement of technology has allowed public discussions of issues which would have usually been offline to go on social media — a new platform for public debate —, subsequently influencing the agenda of other media.

6.4 How much influence does Ghana's online media agenda Twitter and Instagram's agenda?

On the reverse of the discussion in question 6.3 above, the study found that there was a reciprocity of media agendas among Twitter, Instagram and online news media. However, apart from one of the cross-lagged panels — between Time 3 and Time 4 — that suggested a slightly stronger influence of the news websites on both Twitter and Instagram, the news websites had a very weak intermedia influence. This suggests that because Twitter and Instagram are now interested in 'conventional' topics such as crime, corruption, politics, economy etc, their

activities end up influencing the news production process of the online media. As concluded by Katachie's (2017) study, a social media networking site like Twitter may influence news media activities as a result of their constant monitoring and sourcing from the social networking sites (Katachie, 2017).

6.5 What is the intermedia relationship between Twitter and Instagram?

Throughout the study, Twitter and Instagram together were found to have influenced online news media agenda. However, this study also sought to find whether they will exert the same influence on each other. It was found that Twitter and Instagram influenced each other although Twitter's influence was stronger most of the time. It is interesting to note that, the two social media at some of the time spans were interested in different issues. The understanding of this may be that Twitter lends itself to being more of a platform for public debate than Instagram with so many actors such as politicians, celebrities, religious and the social media savvy. Instagram, on the other hand, allows people to share personal experiences and opinions but the conversations on this opinion is limited. This can also be attributed to the user interface of the platform.

6.5 What role do Twitter and Instagram play in the news production process of online news media?

Some themes emerged from the qualitative interviews that explained social media's role in the online news media. The themes ranged from social media's role as a source of news to social media being a tools for verification and social media users as news agents.

On sourcing of news, the respondents shared how important it was to monitor social media like Twitter and Instagram for news ideas. For one of the respondents, it was required that journalists in their media outlet to consistently be abreast with issues on social media. Because of this, they

visited the pages of celebrities, politicians and other ‘big people’ in the society to see what they have posted. Additionally, they monitored the accounts of ordinary people whose activities were making issues trend on the platforms. Another insight that was gathered is that some online news media focused on trending issues that were trending on Twitter and Instagram while others were only interested in stories of national interest.

Verification is key to the newsgathering process. The findings suggested that Twitter and Instagram act as verification tools for online journalists. With this, they are able to go back to the original source that tweeted or posted an issue even when other online media have reported it.

Additionally, the study found that Twitter and Instagram significant roles in the newsrooms because of how the users have positioned themselves as news agents. The respondents admitted that they sometimes get messages from people on leads to certain issues. The assumption is that most social media users see themselves as citizen journalists who see it as their duty to inform other people. Their interest in talking about issues may point reporters to angles they would have otherwise overlooked. Equally, the online news websites use Twitter and Instagram as a channel to share links to their stories, short clips and infographics. Therefore, the findings of this study also offer evidence to Gearhart and Kang’s (2014) study that concluded that comments on social media sites, especially Twitter, that possess journalistic values do not only affect audiences, they also affect journalists. Additionally, it confirms Deo-Silas’ (2013) study that found that a majority of journalists used social media to source news and do research because it presents some kind of ease. This may account for the reason why, as already discussed. Twitter had a stronger influence on the news websites.

Sikanku (2012), in an intermedia agenda-setting study between newspaper and non-newspaper websites concluded that intermedia agenda-setting in Ghana's media terrain is mixed and vigorous. The findings of this current study further add to Sikanku's (2012) conclusion that the intermedia agenda-setting mix in the Ghanaian media landscape is more vigorous than some years ago when the proliferation of the internet and social media use was not so rife in Ghana.

Additionally, the findings point to social media's active role in intermedia agenda-setting in Ghana and how the daily activities of the 'public newsroom' on Twitter, Instagram, Facebook and others influence not only online media but mainstream media actors such as television, radio and print newspapers on what issues to focus their attention on and the kind of angles to pay attention to.

6.6 Chapter Summary

In this chapter, the findings of the study were discussed in relation to related studies and the theory underpinning the study.

CHAPTER SEVEN

CONCLUSION AND RECOMMENDATIONS

7.0 Introduction

This final chapter presents the summary, conclusion of the entire study and recommendations for future studies based on the findings and discussions in previous chapters. Furthermore, it also presents limitations that were encountered while undertaking this study.

This study sought to investigate the intermedia agenda-setting influences among Twitter, Instagram and selected online news websites in Ghana over a two-week period in March 2019. After a thorough analysis of both qualitative and quantitative data, the findings revealed that the intermedia agenda-setting between social media and online media is a two-way kind of relationship, although social media tended to have a strong influence on the online media. The findings furthermore suggested that this reciprocal relationship depended on time and type of issue and also showed social media's active role in intermedia-agenda setting in Ghana.

7.1 Summary of Key Findings

This study identified some key findings. Some of them, although expected, had some new dimensions. The study found that most of the agendas on Twitter and Instagram reflected the agenda of the online news websites. Issues relating to the economy, politics, electricity (power), governance and corruption, which were considered to be conventional topics for online news websites were found to be the agendas on Twitter and Instagram. However, on the other hand, entertainment issues and celebrity scandals, which were also considered to be things that social media would be concerned about were found to be part of the top news agendas on the online news website. The study also found that social media such as Instagram was particularly interested in social issues like gender and relationships.

Additionally, this study found that both the two social media and online media set their original agenda. However, the study found that Twitter and Instagram were more interested in discussing online media agenda by sharing and adding comments to links from online news websites.

Furthermore, the study found that Twitter and Instagram put together had a strong intermedia agenda-setting impact on the news websites. The findings also indicated that of the two social media, Twitter's influence was greater. However, with Instagram alone, the news websites exerted some influence on Instagram, although not high enough to have entirely changed the discourse on Instagram.

Also, in testing the influence of the news websites on Twitter and Instagram, the study found that even though intermedia-agenda-setting occurred in most of the time spans, the influence that was being transferred from the news websites to the two social media networking sites were not strong enough. The only time the news websites exerted a stronger influence on the two social media put together was between Time 3 and Time 4.

Finally, interviews with editors of two online news websites sampled, the study found that because of social media's current position in media activities, reporters and editors now look to Twitter and Instagram for all kinds of news leads. They monitor trending issues and pick interesting angles to develop into news stories. The two social media platforms were further found to be used as sources of verification for news outlets.

The conclusion that can be drawn from this study is that, there is an intermedia agenda-setting relationship between social media (Twitter and Instagram) and news websites in Ghana.

Although social media's influence is higher on the news websites, there still exist some reciprocity.

7.2 Limitations of the Study

This study was not devoid of some limitations. One of the major limitations of this study was that, there was not enough literature on the subject of intermedia agenda-setting in the Ghanaian or African context. The unintended consequence is that, the researcher found it difficult to discuss the findings in relation to existing findings in that context which would have been very useful. However, it also made a good argument for conducting this study.

Also, some of the online news websites sampled did not have dates and time attached to the post and it made it difficult to tell when those news items were posted. This might have probably led to multiple coding of the same stories for different time spans.

Furthermore, the study only focused on Twitter and Instagram posts without engaging the people behind those posts. This could have allowed to understand their motivation for the kind of posts they put on social media and why that was a good avenue for the. Also, due to time constraints, the researcher limited the number of news websites that were used for the study to just five. Future studies could look at ten news websites.

7.3 Recommendations for Future Research

Based on the limitations discussed above, this study recommends that the intermedia-agenda setting research in Ghana can be extended to cover other social media networks such as Facebook, WhatsApp and YouTube. The number of news websites could also be increased to ten. Additionally, it is recommended that other studies look into the influence of individual social media users to understand the category of people whose activities are able to influence other social media users who in turn influence the media.

Moreover, future researchers can try to look into the intermedia agenda-setting influence among members of only the online news websites as data collected suggested that some of the news websites influence others on different issue categories.

7.4 Conclusion

In an era where social media use is growing in Ghana, this study attempted to investigate the intermedia agenda-setting among Twitter, Instagram and five selected online news websites in Ghana (*Myjoyonline.com*, *Yen.com.gh*, *Ghananewsagency.org*, *Citinewsroom.com* and *Pulse.com.gh*). The study sought to answer the questions of whether the agendas on Twitter and Instagram reflected the agenda of the online media and vice versa. Additionally, it sought to measure the influence of Twitter and Instagram on online media and the other way round. The study also explored whether there was an intermedia agenda-setting relationship among social media networking platforms while also trying to investigate Twitter and Instagram's usefulness to news production processes of online news media.

The study used descriptive statistical tools such as frequency distribution tables to measure salience of issues on the platforms as well as cross-lagged correlation panels to measure the influence of one medium on another. Qualitative interviews of two editors of the sampled online news websites were conducted and analyzed to also understand how social media influenced the newsroom agenda.

The study found that among the two social media —Twitter and Instagram—, Twitter had a strong influence on the online media's agenda. The intermedia relationship between the two, Twitter and Instagram, was sometimes reciprocal. On the other hand, Instagram and the online media did not influence each other in ways that could totally change their agendas. However,

putting the two social media together, their influence was stronger on the news websites. This influence shows social media's role in the public discourse in Ghana. It therefore indicates that media practitioners should see social media as an important part of their activities and put structured measures in place to help them make use of social media effectively.

The findings further indicated that, apart from certain peculiar issue categories, Twitter and the online media were dominated by the same issue categories such as politics, corruption, economy and entertainment. Although Instagram shared in most of these issue categories, it was mostly concerned with entertainment and social issues such as gender and relationships.

The three media sampled were capable of setting their own agenda. However, this capability was dependent on the type of issue and the time. The findings of the study also pointed out that although they were all capable of setting their own agenda, the two social media usually rehashed online media's agenda suggesting that no matter how social media users set their own agenda, they are likely to back their arguments with links from the online news websites for credibility.

Interestingly, this study realized that there was an intermedia relationship among the different social media. The findings indicated that Twitter usually influenced the discourse on Instagram as most Instagram users shared screenshots of Twitter content.

Additionally, the study brings to the realization that social media —Twitter and Instagram — agenda was ephemeral. This is because the study had anticipated certain events that preceded the time frame for data collection like the Ayawaso West Wuogon by-election violence and kidnapping issues to take over the agendas of Twitter and Instagram. However, they were not. This suggests that social media networking sites, because of their immediate nature, were

concerned with ‘fresh’ agendas every day as a result of the different kinds of actors on the platforms and the agendas they might want to push.

Although the findings from this study cannot be entirely generalized, they demonstrate that social media has become a key part of Ghana’s media sphere and that their activities play important roles in the news selection decisions of journalists.

7.5 Chapter Summary

This chapter presented the summary of the key findings of this study, the limitations of the study as well as the researcher’s recommendations based on the findings of this current study. One of the recommendations was that intermedia agenda-setting in Ghana could be studied among only members of the online media in future research. The chapter also presented concluding discussions of the study.

BIBLIOGRAPHY

- Aral, S., & Zhao, M. (2019). Social Media Sharing and Online News Consumption. *SSRN Electronic Journal*. doi:10.2139/ssrn.3328864
- Babbie, E. (2019). *The practice of social research*. Belmont, CA: Wadsworth Cengage Learning.
- Banducci, S., Cioroianu, I., Coan, T., Katz, G., & Stevens, D. (2018). Intermedia agenda setting in personalized campaigns: How news media influence the importance of leaders. *Electoral Studies*, 54, 281-288. doi:10.1016/j.electstud.2018.04.011
- Becker, G. (2000). Creating Comparability Among Reliability Coefficients: The Case of Cronbach Alpha and Cohen Kappa. *Psychological Reports*, 87(7), 1171. doi:10.2466/pr0.87.7.1171-1182
- Besley, T., & Burgess, R. (2001). Political agency, government responsiveness and the role of the media. *European Economic Review*, 45(4-6), 629-640. doi:10.1016/s00142921(01)00133-7
- Brannock Cox, J. (2014). News You Need to Know: Examining the Prioritization of News Content in Print and Online Publications. *Journal of Mass Communication & Journalism*, 04(08). doi:10.4172/2165-7912.1000210
- Conway, B. A., Kenski, K., & Wang, D. (2015). The Rise of Twitter in the Political Campaign: Searching for Intermedia Agenda-Setting Effects in the Presidential Primary. *Journal of Computer-Mediated Communication*, 20(4), 363-380. doi:10.1111/jcc4.12124
- Conway, B. A., Kenski, K., & Wang, D. (2015). The Rise of Twitter in the Political Campaign: Searching for Intermedia Agenda-Setting Effects in the Presidential Primary. *Journal of Computer-Mediated Communication*, 20(4), 363-380. doi:10.1111/jcc4.12124
- Borah, Porismita. (2016). Media Effects Theory. 10.1002/9781118541555.wbiepc156.
- Bird, S. E. (2011). Are We All Producers Now? *Cultural Studies*, 25(4-5), 502-516. doi:10.1080/09502386.2011.600532
- Breed, W. 1955. "Newspaper 'Opinion Leaders' and Processes of Standardization." *Journalism and Mass Communication Quarterly* 32 (3): 277-84
<https://doi.org/10.1177/107769905503200302>
- Browser, OS, Search Engine including Mobile Usage Share. (n.d.). Retrieved May 3, 2019, from <http://gs.statcounter.com/>

- Bryman, A. (2006). Integrating quantitative and qualitative research: how is it done? *Qualitative Research*, 6(1), 97–113. <https://doi.org/10.1177/1468794106058877>
- Camaj, L. (2013). The Media's Role in Fighting Corruption: Media Effects on Governmental Accountability. *The International Journal of Press/Politics*, 18(1), 21–42. <https://doi.org/10.1177/1940161212462741>
- Cohen, B.C. (1963) *The Press and Foreign Policy*. Princeton University Press, Princeton, 627.
- Creswell, J. W. (2009). *Research Design: Qualitative, Quantitative and Mixed Approaches* (3rd Edition). Research Design: Qualitative, Quantitative, and Mixed Methods Approaches. <https://doi.org/10.2307/1523157>.
- Creswell, J. W., & Creswell, J. D. (2013). *Research Design: Qualitative, Quantitative, and Mixed Methods Approaches*. Erscheinungsort nicht ermittelbar: SAGE Publications.
- Cushion, A., Thomas, R., & Kilby, A. (2016). Newspapers, Impartiality and Television News. *The International Journal of Press/Politics*, Vol 21(12). Retrieved June 17, 2019.
- Dalton, R. J., Beck, P. A., Huckfeldt, R., & Koetzle, W. (1998). A Test of Media-Centered Agenda Setting: Newspaper Content and Public Interests in a Presidential Election. *Political Communication*, 15(4), 463-481. doi:10.1080/105846098198849
- Dearing, J. & Rogers, E. (1996). *Communication Concepts 6: Agenda-setting* Thousand Oaks, CA: SAGE Publications, Inc. doi: 10.4135/9781452243283
- Deo-Silas, K. (2013). Newsroom journalists' use of social media in Ghana.
- Di Cui & Fang Wu (2017) Inter-media agenda setting in global news production: examining agenda attributes in newspaper coverage of the MH370 incident in the U.S., China, and Hong Kong, *Asian Journal of Communication*, 27:6, 582-600, DOI: 10.1080/01292986.2017.1305426
- Du, Y. R. (2012). Intermedia agenda-setting in the age of globalization: A multinational agendasetting test. *Global Media and Communication*, 9(1), 19-36. doi:10.1177/1742766512463038
- Elawad, S. H. (2017). First and Second-level Intermedia Agenda-setting between Social Media and Mainstream Media: a Study of the 2015 Sudanese Presidential Election. *The Journal of Scientific Social Studies*, 1(3), 20-37. doi:10.26484/2017/tjsss00317073
- Erbring, L., Goldenberg, E. N., & Miller, A. H. (1980). Front-Page News and Real-World Cues:

- A New Look at Agenda-Setting by the Media. *American Journal of Political Science*, 24(1), 16. doi:10.2307/2110923
- Eli Skogerbø & Arne H. Krumsvik (2015) Newspapers, Facebook and Twitter, *Journalism Practice*, 9:3, 350-366, DOI: [10.1080/17512786.2014.950471](https://doi.org/10.1080/17512786.2014.950471)
- Farhi, P. (2009). The Twitter explosion: Whether they are reporting about it, finding sources on it or urging viewers, listeners and readers to follow them on it, journalists just can't seem to get enough of the social networking service. Just how effective is it as a journalism tool? *American Journalism Review.*, 31(3), 26. Retrieved June 21, 2019.
- Feezell, J. T. (2018). Agenda Setting through Social Media: The Importance of Incidental News Exposure and Social Filtering in the Digital Era. *Political Research Quarterly*, 71(2), 482–494.
- Freeman, A. (2012). An Overview of Agenda Setting Theory in Mass Communications. Retrieved June 21, 2019.
- Frederick, E. L., Burch, L. M., & Blaszk, M. (2015). A Shift in Set: Examining the Presence of Agenda Setting on Twitter During the 2012 London Olympics. *Communication & Sport*, 3(3), 312–333. <https://doi.org/10.1177/2167479513508393>
- Gearhart, S., & Kang, S. (2014). Social Media in Television News. *Electronic News*, 8(4), 243259. doi:10.1177/1931243114567565
- Golan, G. (2006). Inter-media agenda setting and global news coverage. *Journalism Studies*, 7(2), 323-333. DOI: 10.1080/14616700500533643
- Global No.1 Business Data Platform. (n.d.). Retrieved April 5, 2019, from <https://www.statista.com/>
- Gross, L. (2009). My Media Studies: Cultivation to Participation. *Television & New Media*, 10(1), 66–68. <https://doi.org/10.1177/1527476408325105>
- Guo, L., & Vargo, C. J. (2017). Global Intermedia Agenda Setting: A Big Data Analysis of International News Flow. *Journal of Communication*, 67(4), 499-520. doi:10.1111/jcom.12311
- Harder, R. A., Sevenans, J., & Aelst, P. V. (2017). Intermedia Agenda Setting in the Social Media Age: How Traditional Players Dominate the News Agenda in Election Times. *The International Journal of Press/Politics*, 22(3), 275-293.
- Hargittai, E. and Litt, E. (2011) The Tweet Smell of Celebrity Success: Explaining Variation in Twitter Adoption among a Diverse Group of Young Adults. *New Media & Society*, 1, 170-179. <http://dx.doi.org/10.1177/1461444811405805>

- Haggarty, L. (1996). What is content analysis? *Medical Teacher*, 99-101, DOI: [10.3109/01421599609034141](https://doi.org/10.3109/01421599609034141)org.au/index.php/mcjournal/article/view/220
- Hedding, K. J., & Ripka, K. (2018). What's political Twitter talking about? *Fifty years of agenda-setting research*, 2(2), 168-190. doi:10.1075/asj.18018.hed
- Hermida, A. (2010a). From TV to Twitter: How Ambient News Became Ambient
- Hermida, A. (2010b). Twittering the news. *Journalism Practice*, 4(3), 297-308. DOI: [Journalism. M/C Journal](https://doi.org/10.1080/15227029.2010.500000), 13(2). Retrieved from <http://journal.mediaculture.com>.
- Internet Live Stats - Internet Usage & Social Media Statistics. (n.d.). Retrieved from <https://www.internetlivestats.com/>
- Johnson, T. J. (2014). *Agenda setting in a 2.0 world: New agendas in communication*. New York: Routledge.
- Kaplan, A. M., & Haenlein, M. (2012). Social media: Back to the roots and back to the future. *Journal of Systems and Information Technology*, 14(2), 101-104. doi:10.1108/13287261211232126
- Kalsnes, B. (2016). Intermedia agenda setting: Political journalists' source hunting on social media. *Intermedia Agenda Setting: Political Journalists' Source Hunting on Social Media*, 1, 12-31. Retrieved January 6, 2019.
- Katachie, S. (2017). The Inter-Media Agenda-Setting influence of Twitter on traditional media In Ghana during the 2016 Ghanaian Elections.
- Krane, M. (n.d.). The socially filtered media agenda: a study of agenda setting among news outlets on Twitter. doi:10.32469/10355/8129
- Keyword Research, Competitor Analysis, & Website Ranking | Alexa. (n.d.). Retrieved from <https://www.alexa.com/>
- Kim, Y., Kim, Y., & Zhou, S. (2017). Theoretical and methodological trends of agenda-setting theory. *The Agenda Setting Journal*, 1(1), 5-22. doi:10.1075/asj.1.1.03
- Ku, G., Kaid, L. L., & Pfau, M. (2003). The Impact of Web Site Campaigning on Traditional News Media and Public Information Processing. *Journalism & Mass Communication Quarterly*, 80(3), 528-547. doi:10.1177/107769900308000304

- Kwak, H. & Lee, C. & Park, H. & Moon, S. (2010). What Is Twitter, a Social Network or a News Media? Proceedings of the 19th International Conference on World Wide Web, WWW '10. 19. 10.1145/1772690.1772751.
- Leech N., Onwuegbuzie A., (2008) A typology of mixed methods research designs, *Quality and Quantity*, 43(2), March, pp. 265-275.
- Lim, J. (2011). First-level and second-level intermedia agenda-setting among major news websites. *Asian Journal of Communication*, 21(2), 167–185.
doi:10.1080/01292986.2010.539300
- Lee, B., Kim, J., & Scheufele, D. A. (2015). Agenda Setting in the Internet Age: The Reciprocity between Online Searches and Issue Salience. *International Journal of Public Opinion Research*, 28(3), 440-455. doi:10.1093/ijpor/edv026
- Lee, B., Lancendorfer, K. M., & Lee, K. J. (2005). Agenda-setting and the Internet: The inter-media influence of Internet bulletin boards on newspaper coverage of the 2000 general election in South Korea. *Asian Journal of Communication*, 15(1).
- Lee, G. (2004). Do you mirror me? Inter-media agenda-setting effects among eight online media in Korea. Paper presented to the International Communication Division at the annual convention of the Association for Education in Journalism and Mass Communication, Toronto, Canada
- Lennon, E. L. (1998). Two Levels of Agenda Setting Among Advertising and News in the 1995 Spanish Elections. *Political Communication*, 15(2), 225-238.
doi:10.1080/105846098199046
- Lopez-Escobar, E., Llamas, J. P., McCombs, M. E., & Lennon, F. R. (1998). Two levels of agenda-setting among advertising and news in the 1995 Spanish elections. *Political Communication*, 15(2), 225-238.
- Lough, K., & Mohammed, S. (2019). The pictures in our pages. *Fifty Years of Agenda-setting Research the Agenda Setting Journal the Agenda Setting Journal. Theory, Practice, Critique*, 3(1), 82-102. doi:10.1075/asj.18009.lou
- Luo, Y., Burley, H., Moe, A., & Sui, M. (2018). A Meta-Analysis of News Media's Public Agenda-Setting Effects, 1972-2015. *Journalism & Mass Communication Quarterly*, 96(1), 150–172.
- Lysak, S., Cremedas, M., & Wolf, J. (2012). Facebook and Twitter in the Newsroom: How and Why Local Television News is Getting Social with Viewers? *Electronic News*, 6(4), 187–207. <https://doi.org/10.1177/1931243112466095>

- Maclean F, Jones D, Carin-Levy G, Hunter H (2013) Understanding Twitter. *British Journal of Occupational Therapy*, 76(6), 295-298.
- Mccombs, M. & Valenzuela, S. (2007). The Agenda-Setting Theory. *Cuadernos de información*, ISSN 0717-8697, N°. 20, 2007, pages. 44-50. 10.7764/cdi.20.111.
- Mccombs, M. E., & Guo, L. (2014). Agenda-Setting Influence of the Media in the Public Sphere. *The Handbook of Media and Mass Communication Theory*, 249-268. doi:10.1002/9781118591178.ch14
- McCombs, M. E. (n.d.). New Directions in Agenda-Setting Theory and Research. *Advances in Foundational Mass Communication Theories*, 131-152. doi:10.4324/9781315164441-9
- McCombs, M., & Shaw, D. (1972). The Agenda-Setting Function of Mass Media. *The Public Opinion Quarterly*, 36(2), 176-187. Retrieved from <http://www.jstor.org/stable/2747787>
- McCombs, M., & Shaw, D. L. (1993). The evolution of agenda setting research: Twenty-five years in the marketplace of ideas. *Journal of Communication*, 43, 58-67.
- Mccombs, M., & Shaw, D. (2017). The agenda-setting function of mass media. *The Agenda Setting Journal the Agenda Setting Journal. Theory, Practice, Critique*, 1(2), 105-116. doi:10.1075/asj.1.2.02mcc
- Meraz, S. (2011). Using Time Series Analysis to Measure Intermedia Agenda-Setting Influence in Traditional Media and Political Blog Networks. *Journalism & Mass Communication Quarterly*, 88(1), 176-194. doi:10.1177/107769901108800110
- Morris, M. and Ogan, C. (1996), The Internet as Mass Medium. *Journal of Communication*, 46: 39-50. doi:10.1111/j.1460-2466.1996.tb01460.x
- Nowak-Teter, E. (2018). Agenda-setting theory and the new media. 33.
- Onwuegbuzie, A. J., & Dickinson, W. B. (2008). Mixed Methods Analysis and Information Visualization: Graphical Display for Effective Communication of Research Results. *The Qualitative Report*, 13(2), 204-225. Retrieved from <https://nsuworks.nova.edu/tqr/vol13/iss2/5>
- Regan, K. (2015). 10 Amazing Social Media Growth Stats From 2015, *SocialMediaToday*, August 10, 2015, from <http://www.socialmediatoday.com/social-networks/kadie-regan/2015-08-10/10-amazing-social-media-growth-stats-2015>
- Roberts, M., Wanta, W., & Dzwo, T. (. (2002). Agenda Setting and Issue Salienc Online. *Communication Research*, 29(4), 452-465. doi:10.1177/0093650202029004004

- Rogstad, I. (2016). Is Twitter just rehashing? Intermedia agenda setting between Twitter and mainstream media. *Journal of Information Technology & Politics*, 13(2), 142-158.
- Rössler, P. (2015). The Agenda-Setting Function of Mass Media. *Schlüsselwerke Der Medienwirkungsforschung*, 121-133. doi:10.1007/978-3-658-09923-7_11
- Russell Neuman, W., Guggenheim, L., Mo Jang, S., & Bae, S. Y. (2014). The Dynamics of Public Attention: Agenda-Setting Theory Meets Big Data. *Journal of Communication*, 64(2), 193-214. doi:10.1111/jcom.12088
- Shehata, A., & Strömbäck, J. (2013). Not (Yet) a New Era of Minimal Effects. *The International Journal of Press/Politics*, 18(2), 234-255. doi:10.1177/1940161212473831
- Shoemaker, P. J., Wanta, W., & Leggett, D. (1989). Drug coverage and public opinion. In P. J. Shoemaker (Ed.), *Communication campaigns about drugs: Government, media, and the public* (pp. 67-80). Hillsdale, NJ: Lawrence Erlbaum.
- Sikanku, E. G. (2011). Intermedia Influences Among Ghanaian Online and Print News Media. *Journal of Black Studies*, 42(8), 1320-1335.
- Sikanku, E. G. (n.d.). Inter-media agenda-setting effects in Ghana: newspaper vs. online and state vs. private. doi:10.31274/rtd-180813-16641
- Skogerbø, E., & Krumsvik, A. H. (2014). Newspapers, Facebook and Twitter. *Journalism Practice*, 9(3), 350-366. doi:10.1080/17512786.2014.950471
- Stone, G. C., & McCombs, M. E. (1981). Tracing the Time Lag in Agenda-Setting. *Journalism Quarterly*, 58(1), 51-55. <https://doi.org/10.1177/107769908105800108>
- Sweetser, K., Golan, G., & Wanta, W., (2008). Intermedia Agenda Setting in Television, Advertising, and Blogs During the 2004 Election. *Mass Communication & Society*.
- Towner, T. L., & Muñoz, C. L. (2018). Picture Perfect? The Role of Instagram in Issue Agenda Setting During the 2016 Presidential Primary Campaign. *Social Science Computer Review*, 36(4), 484-499. <https://doi.org/10.1177/0894439317728222>
- Vliegthart, R., & Walgrave, S. (2008). The Contingency of Intermedia Agenda Setting: A Longitudinal Study in Belgium. *Journalism & Mass Communication Quarterly*, 85(4), 860-877.
- Vonbun, R., Königslöw, K. K., & Schoenbach, K. (2016). Intermedia agenda-setting in a multimedia news environment. *Journalism: Theory, Practice & Criticism*, 17(8), 10541073.

- Vonbun, R., Königslöw, K. K., & Schoenbach, K. (2016). Intermedia agenda-setting in a multimedia news environment. *Journalism*, 17(8), 1054–1073.
- Vorderer, P., Park, D. W., & Lutz, S. (2019). A History of Media Effects Research Traditions. *Media Effects*, 1-15. doi:10.4324/9780429491146-1
- Wanta, W., Golan, G., & Lee, C. (2004). Agenda Setting and International News: Media Influence on Public Perceptions of Foreign Nations. *Journalism & Mass Communication Quarterly*, 81(2), 364–377. <https://doi.org/10.1177/107769900408100209>
- Wallsten, Kevin. (2007). Agenda Setting and the Blogosphere: An Analysis of the Relationship Between Mainstream Media and Political Blogs. *Review of Policy Research*. 24. 567587. 10.1111/j.1541-1338.2007.00300. x.
- Weimann, G., & Brosius, H. B. (2016). A new agenda for agenda-setting research in the digital era. In G. Vowe & P. Henn (Eds.), *Political Communication in the Online World Theoretical Approaches and Research Designs* (S. 26–44). New York: Routledge.
- Wimmer, R. D., & Dominick, J. R. (2006). *Mass Media Research: An Introduction* (8th ed.). Belmont, CA: Thomson Wadsworth Publishing.
- Winter, J. P., & Eyal, C. H. (n.d.). *An Agenda-Setting Time-Frame for the Civil Rights Issue, 1954-1976*.
- Zhang, X. (2018), ‘Intermedia agenda-setting effect in corporate news: Examining the influence of *The New York Times* and *The Wall Street Journal* on local newspapers’, *Journal of Applied Journalism & Media Studies*, 7:2, pp. 245–63, doi: 10.1386/ajms.7.2.245_1

APPENDIX A

**CODING SHEET FOR INTERMEDIA AGENDA SETTING AMONG
TWITTER, INSTAGRAM AND ONLINE NEWS WEBSITES IN GHANA**

Serial	Summary/Headline	Issue Category	Source	Time Span

APPENDIX B CODING GUIDE

Variable	Coding Instruction	Code
Serial	Number the news article/Twitter/Instagram post consecutively starting from 1.	For instance, 1, 2, 3...
Summary	The headline of the news story or the summary of the Twitter or Instagram post to be written out as string For example: Ayawaso By-Election Violence	
Issue Category	<p>Categorize news article/ Twitter/ Instagram posts under any of the categories or themes listed below:</p> <ol style="list-style-type: none"> 1. Elections, electoral violence and vigilantism: News articles, posts and tweets relating to electoral violence for example the Ayawaso by-election violence, political party vigilantism, electoral commission, upcoming presidential polls etc. 2. Politics, corruption and governance: News articles, posts and tweets relating to corruption, local governance, misappropriation of funds, ministries, new government projects etc. 3. Economy, cedi depreciation and employment: News articles, posts and tweets relating to economic crisis, businesses, new economic policies, labour strikes, unemployment issues, falling of the cedi, government's promises to rescue the cedi, cedi-dollar rate etc. 4. Security, kidnapping and crime: News articles, posts and tweets relating to kidnappings, violence, robbery, mobile money scams etc. 5. Electricity ((Dumsor), energy and transport: News items and posts related to power cuts, PDS, ECG, 'Dumsor', accidents, road issues, traffic problem, energy etc. 6. Entertainment and celebrity scandals: News, posts and tweets related to entertainment, celebrity scandals, celebrity lifestyles, gossip, music etc. 7. Education, youth and technology: News, posts and tweets relating to free SHS, law school and teacher trainee licensure 	<p>1</p> <p>2</p> <p>3</p> <p>4</p> <p>5</p> <p>6</p> <p>7</p>

	<p>exams, Double track system, teacher association strikes, education policies etc.</p> <p>8. Foreign and local sports: News, posts and tweets related to football, athletics, foreign sports, local league, football stars, Ghana Football Association Normalization committee reports, African Cup of Nations etc</p> <p>9. Social issues: News, posts and tweets relating to gender and children, domestic violence, women empowerment, sex, relationship issues etc.</p> <p>10. Religion and Spirituality: News articles, posts and tweets relating to church issues, religious views by prominent people, controversial spiritual issues etc.</p> <p>11. Foreign news commentary: News items, posts and tweets about other countries, crisis in other countries commented on by Ghanaians etc.</p> <p>12. Health, lifestyle and sanitation: News, posts and tweets about health issues, lifestyle, sanitation, flooding and sanitation related matters.</p>	<p>8</p> <p>9</p> <p>10</p> <p>11</p> <p>12</p>
Source	<p>Indicate the source of the article or post.</p> <ol style="list-style-type: none"> 1. Twitter 2. Instagram 3. Myjoyonline.com 4. Yen.com.gh 5. Ghananewsagency.org 6. Pulse.com.gh 7. Citinewsroom.com 	<p>1</p> <p>2</p> <p>3</p> <p>4</p> <p>5</p> <p>6</p> <p>7</p>
Time	<p>Indicate the time frame of the article or post by selecting from the options below: Time 1 – (T1)</p> <p>Time 2 – (T2)</p> <p>Time 3 – (T3)</p> <p>Time 4 – (T4)</p>	<p>1</p> <p>2</p> <p>3</p> <p>4</p>

APPENDIX C

INTERVIEW GUIDE

My name is Eugene Brown Nyarko Agyei, a Master of Philosophy student from the Department of Communication Studies of the University of Ghana. I am conducting a research on the intermedia agenda-setting influences between new and legacy media, specifically among Twitter, Instagram and five selected online news websites in Ghana. The main purpose of the study is to investigate how these social media networks and online news websites influence one another on issues. Your responses will be treated with utmost confidentiality and will be used solely for academic purposes only.

Your participation will be appreciated.

Questions

1. Does your news organization allow you to check social media for news?
2. How often do you check social media sites for story ideas?
3. Do you intentionally monitor Twitter or Instagram to get stories?
4. Do you decide on stories based on trending topics on social media?
5. How does social media change your reporting schedules?
6. When you post stories on your social media pages, do you check your posts up for comments?
7. How do you verify issues from social media before they become news stories?
8. Does your newsroom set out to make certain stories go viral on social media?
9. Which kind of social media (Twitter/Instagram) users are you likely to believe their posts on these platforms?
10. How important is social media to you as an online editor

11. How important are social media users to the activities of the newsroom