

UNIVERSITY OF GHANA

COLLEGE OF HUMANITIES

**NEUROPSYCHOLOGICAL FUNCTIONING IN SYSTEMIC LUPUS
ERYTHEMATOSUS**

BY

NORAH NKORNU

(10390324)

**THIS THESIS IS SUBMITTED TO THE UNIVERSITY OF GHANA,
LEGON**

**IN PARTIAL FULFILLMENT OF THE REQUIREMENT FOR THE
AWARD OF MPhil
CLINICAL PSYCHOLOGY DEGREE**

JULY, 2019

DECLARATION

I hereby declare that with the exception of the references used which are duly acknowledge, this thesis is my own work submitted for the award of MPhil Clinical Psychology to the Department of Psychology, University of Ghana.

Norah Nkornu

Signature.....
(Student)

Date:.....

Professor C. Charles Mate-Kole

Signature.....
(Principal Supervisor)

Date:

Dr. E. Teye-Kwadjo

Signature.....
(Co-Supervisor)

Date:

DEDICATION

I dedicate this master thesis to all Systemic Lupus Erythematosus patients. Keep on keeping on.

ACKNOWLEDGEMENT

Glory be unto the name of the Lord God almighty for His grace and favour has been adequate. The production of this work has received great support from individuals who deserve much acknowledgement and gratitude. I am much grateful to my first supervisor Professor C.C. Mate-Kole whose suggestions, inputs and directives guided the writing of this thesis. My second acknowledgement goes to Dr. Dzifa Dey for your tremendous support with the data collection, I appreciate your support. To my second supervisor Dr. E. Teye-Kwadjo, I appreciate your corrections and guidance. Special gratitude goes to my dad, Mr. Frank Nkornu Agbavor for your prayers and support in all spheres of my life. I say thank you. Lastly, I wish to extend my gratitude to all friends including anonymous reviewers who supported me in one way or the other.

ABSTRACT

Systemic Lupus Erythematosus is a disorder in which a person's immune system attacks the tissues and organs of the body, causing inflammation, damage and dysfunction. Challenges associated with SLE include cognitive and behavioural changes as well as problems with perceived quality of life. It affects mainly women in their prime in Sub-Saharan Africa. This study examined the neuropsychological functioning of individuals with systemic lupus erythematosus (SLE) in Accra, Ghana. The study used a mixed method design; one hundred and thirty five (135) participants comprising 70 SLE patients and 65 healthy controls were recruited from the Korle-bu Teaching Hospital in Accra for the quantitative phase. Eleven SLE patients were further recruited from the same sample for the qualitative phase. Quantitative data was collected using a battery of neuropsychological tests and behavioural measures. The quantitative data was analysed using multivariate analysis of covariance, standard multiple regression analysis, and independent t test. The qualitative data was analysed using thematic analysis. The quantitative results showed statistically significant differences between the SLE patients and the healthy control group on the cognitive tests, the behavioural and the quality of life measures. Further, attention positively predicted quality of life. The qualitative findings revealed the challenges SLE patients encounter, as well as the social support received and coping strategies they adopt. The findings are discussed in relation to enhancing SLE care and management of chronic diseases in Ghana.

TABLE OF CONTENTS

| | |
|--|------|
| DECLARATION | i |
| DEDICATION | ii |
| ACKNOWLEDGEMENT | iii |
| ABSTRACT..... | iv |
| TABLE OF CONTENTS..... | v |
| LIST OF APPENDICES | viii |
| LIST OF TABLES..... | ix |
| LIST OF FIGURES..... | x |
| LIST OF ABBREVIATIONS | xi |
| CHAPTER ONE | 1 |
| INTRODUCTION..... | 1 |
| Background of the study..... | 1 |
| Psychological wellbeing and cognitive function | 6 |
| Statement of the problem | 7 |
| Aim and objectives of the Study | 9 |
| Relevance of the study..... | 10 |
| CHAPTER TWO | 11 |
| LITERATURE REVIEW | 11 |
| Introduction | 11 |
| Theoretical Framework..... | 11 |
| Luria’s model of brain functioning: The Three Functional Units model..... | 11 |
| The Health-Related Quality of Life (HRQOL) Theory (Wilson & Cleary, 1995)..... | 13 |
| Review of Related Studies..... | 14 |
| Neuropsychological deficits in SLE..... | 14 |
| Psychological wellbeing and quality of life in SLE | 17 |
| Rationale of the study..... | 19 |
| Statement of Hypotheses for Quantitative part..... | 20 |
| Research Questions for Qualitative | 20 |
| Proposed Conceptual Model for the Quantitative Part of the Study | 21 |
| CHAPTER THREE | 22 |
| METHODOLOGY | 22 |
| Introduction | 22 |

| | |
|--|-----------|
| Research Design | 22 |
| Sampling Technique and Sample size | 22 |
| Study 1: Quantitative Study | 23 |
| Research Design for the Quantitative Study..... | 23 |
| Study setting | 24 |
| Population and sample for the Quantitative study | 24 |
| Inclusion and Exclusion Criteria | 25 |
| Measures..... | 26 |
| Procedure..... | 31 |
| Piloting the quantitative instruments..... | 31 |
| Quantitative phase..... | 32 |
| Ethical Consideration | 32 |
| Quantitative Data Analyses..... | 32 |
| Study 2: Qualitative study..... | 33 |
| Research design for Qualitative study | 33 |
| Qualitative Sample..... | 34 |
| Measures and Instruments for qualitative study..... | 34 |
| The Pilot Study for qualitative study..... | 34 |
| Qualitative Study..... | 35 |
| Qualitative Data Analyses | 35 |
| CHAPTER FOUR | 37 |
| RESULTS | 37 |
| Introduction | 37 |
| Study 1: Quantitative Results..... | 38 |
| Preliminary Data Analysis | 38 |
| Descriptive Statistics, Normality and Reliability of Variables | 38 |
| Test of Hypotheses..... | 44 |
| Study 2: Qualitative Results | 51 |
| Research Question1: What are the lived psychological experiences of SLE patients?..... | 51 |
| Research question 2: What are the coping mechanism employed by SLE patients? | 60 |
| CHAPTER FIVE | 67 |
| DISCUSSION..... | 67 |
| Figure 5.1: Observed Model..... | 75 |

| | |
|--|----|
| Implications of Findings for Clinical Practice | 75 |
| Limitations of the Study | 76 |
| Direction for future research | 77 |
| Conclusion | 78 |
| REFERENCES | 80 |
| APPENDICES | 98 |

LIST OF APPENDICES

| | |
|---|-----|
| Appendix I Ethical Clearance by ECH..... | 97 |
| Appendix II Consent Form of the Study..... | 98 |
| Appendix III Demographic Questionnaire | 101 |
| Interview Guide for Qualitative..... | 103 |
| Appendix V Summary of Means, SD, Reliability, Skewness and Kurtosis of Variables | 104 |
| Appendix VI Additional Findings | 105 |

LIST OF TABLES

| | |
|--|----|
| Table 4.1: Summary of Means, SD, Reliability, Skewness and Kurtosis of Variables | 38 |
| Table 4.2: Pearson's correlation table of cognitive tests and psychological measure..... | 39 |
| Table 4.3: Pearson's correlation between psychological measure and Quality of life..... | 40 |
| Table 4.4 Frequency and Percentages of Survey Participants SLE'S N = 70 and Healthy Controls (HC) N = 65 | |
| Table 4.5: Summary of MANOVA results for neuropsychological measures | 42 |
| Table 4.6: Summary of MANOVA results for Behavioral measure and Quality of life | 44 |
| Table 4.7: Summary of Standard Multiple Regression for hypothesis three | 46 |
| Table 4.8: Summary of t-test results on QOL between the newly diagnosed SLE patients and those who have lived with the condition for more than 2 years | 49 |
| Table 4.9: Summary of Key Qualitative Findings (Challenges that SLE Patients encounter) | 64 |
| Table 4.10: Social Support that SLE patients receive..... | 65 |
| Table 4.11: Coping Mechanisms by SLE Patients..... | 65 |

LIST OF FIGURES

| | |
|--|-----------|
| Figure 2.1: Proposed Conceptual Framework | 21 |
| Figure 5.1: Observed Model..... | 73 |

LIST OF ABBREVIATIONS

| | |
|-------|---|
| SLE | Systemic Lupus Erythematosus |
| NPSLE | Neuropsychiatric Systemic Lupus Erythematosus |
| FMRI | Functional Magnetic Resonance Imaging |
| CNS | Central Nervous System |
| Rey | Rey -Osterrieth Complex Figure Test |
| MOCA | Montreal Cognitive Assessment |
| CFQ | Cognitive Failures Questionnaire |
| BSI | Brief Symptom Inventory |
| CVLT | California Verbal Learning Test |
| TMT | Trail Making Test |
| COWAT | Controlled Oral Word Association Task |
| SQOL | Spitzer's Quality of Life Revision |
| HC | Healthy Controls |
| QOL | Quality of life |
| KBTH | Korle Bu teaching Hospital |

CHAPTER ONE

INTRODUCTION

Background of the study

Systemic lupus erythematosus (SLE or lupus) is an autoimmune condition of poorly understood pathogenesis which is known to affect women six times more frequently than men and commonly affects women of African descent (Rees et al., 2016). The disease has been reported to be the second most prevalent autoimmune condition which mostly affect women in their reproductive year (Bongu et al., 2002). However, the causes and the medical course of the condition is unclear. A recent international study by the Lupus Foundation of America showed a low global understanding of the disease (Lupus Foundation of America, 2018). In the United States, specifically in North America, the prevalence of SLE is estimated to be between 20 and 150 cases per 100,000 individuals a year (Rees et al., 2016). Africa also recorded 0.3 cases per 100,000 person-years from 1946 to 2016 which according to Rees, et al. (2016) is the lowest incidence. SLE is a disorder in which a person's immune system attacks the tissues and organs of the body, causing inflammation, damage and dysfunction (Shiel, 2018).

The incidence of SLE has increased over the years, primarily due to improvement in the diagnosis of the condition. The predicted occurrence rates varies yearly in the western world between two to eight cases per 100 000 people; Further, disease onset has been estimated to be between the ages of 16 and 55 years among sixty-five per cent of SLE patients (Bertsias et al., 2012).

The epidemiology of SLE in Africa is still unclear (Tiffin et al., 2014), however, some studies have reported SLE cases in South Africa (Tikly et al., 1996; Faller et al., 2005). Furthermore, Molokhia et al. (2001) reported a high occurrence of SLE in immigrants from West Africa.

Abdou et al., (2003) reported on lupus nephritis from all regions of Senegal. Adelowo and Oguntona (2009) reported SLE cases where they defined sequences of the disease diagnosed at a rheumatology clinic in Lagos, Nigeria. It is therefore clear that SLE cases are not uncommon in Africa (Tiffin et al., 2014).

SLE affects any structure of the body (Avina-Zubieta, 2007). The presentation and medical course of the disease are highly variable with some individuals experiencing minimal symptoms such as malar rash and inflammation of the joints and skin, whereas others present with life-threatening involvement of major organs (Bartels, 2017). Further, SLE manifests in different ways and can imitate other conditions making diagnosis difficult (Mayo clinic, 2017). The initial symptoms include fatigue, sun sensitivity and arthralgia, which are ever-present and often short-lived, are frequently ignored or unrecognized, making diagnosis difficult. No two cases of SLE are precisely the same as the appearances of the disease varies from individual to individual and often progresses over time (Mayo clinic, 2017). Symptoms differ from person to person depending on the organs affected and they include excessive tiredness, inflammations and joint pains, headaches, a rash on the cheeks or nose, alopecia, anaemia, blood clotting problems, and discolouration of fingers (Herndon, 2016).

The exact cause of SLE is not known however, several factors including genetics, some environmental factors like excessive exposure to sunlight, infrared lights, certain medications, viruses, physical or emotional stress, and trauma have been associated with the disease (Herndon, 2016). According to Bertias et al., (2012), “epigenetic effects such as DNA methylation and post-translational modifications of histones, which can be either inherited or modified by environmental factors may influence the risk for SLE. Further, they postulated that DNA methylation, which plays a role in a range of human processes, such as X chromosome

inactivation is the most well understood type of epigenetic and has also been implicated in SLE”.

Possible environmental triggers of SLE include excessive exposure to sunlight, infectious viruses like Epstein– Barr virus (EBV), ultraviolet rays, and stress (Herndon, 2016). Demethylating drugs such as procainamide and hydralazine have also been reported to cause drug induced SLE but a genetic predisposition may play a role (Bertsias et al., 2012). These preparations may hinder DNA methylation and prompt over-representation of LFA-1 antigens, there by altering gene expression in CD4+ T cells, promoting auto-reactivity. The response of the immune system against internal nuclear antigens has further been identified as features of SLE (Bertsias et al., 2012). Apoptotic cells release auto-antigens which are delivered by dendritic cells to T cells causing them to be activated; these activated T cells support B cells to generate antibodies to these self-components by releasing cytokines like IL23 and interleukin 10 (IL10) and also by secreting CTLA-4 and CD40L (Bertsias et al., 2012). Current data further supports the self-directing action of T and B cells stimulation; thus numerous cells and molecules are involved in the inherent, adaptive immune reactions and apoptosis that leads to the onset of SLE (Bertsias et al., 2012).

There are a number of treatment options depending on the organs affected. These treatments mostly focus on silencing the immune system to reduce distress with the condition. Hence individuals are able to live a manageable life (Herndon, 2016). Treatment usually involves a combination of antimalarial drugs (Wallace, 2002a) and non-steroidal anti-inflammatory medications (Yousefi & Weisman, 2002). Cytokine drugs (McCune & Riskalla, 2002) and steroids (Kirou & Boumpas, 2002) are also prescribed depending on the organs affected and the severity of symptoms. SLE patients are instructed to try and minimise their stress levels,

avoid very high radiations, get enough rest, and build a good support structure to assist during times of disease activity (Kuper & Failla, 2000; Wallace, 2002).

SLE and Cognitive functions

The impact of central nervous system problems are varied in SLE, and of particular concern is the cognitive decline (Butt et al., 2017).

Neuropsychiatric conditions in SLE include psychotic episodes to mood changes, cognitive problems, headaches, seizures, and stroke (West, 2013). Cognitive dysfunction which is defined as a notable deficit in any of the various cognitive domains including memory, attention, executive function, visual-spatial processing, psychomotor speed and verbal fluency has been highlighted as a key neuropsychiatric complaint in SLE (Huerta et al., 2015). Some studies have also reported central nervous system (CNS) involvement in SLE, these include structural changes to the amygdala and hippocampus (Jung et al., 2010).

Other studies have suggested autoantibody activity and cerebral ischemia as the likely mechanisms responsible for cognitive deficits in SLE (Hanly, 2013). Health characteristics such as disease mechanism and duration, usage of some medications, pro-inflammatory cytokines and behavioural elements have further been suggested (Prabu et al., 2010). Another possible mechanism of cognitive impairment in SLE could be attributed to the function of a subset of anti-DNA antibodies that inter-reacts with particular sequences available on NR2 receptors (Conti et al., 2012). Glutamate binds to these NR2 receptors and causes an activation effect; these NR2 receptors have been identified to be highly present in the hippocampus, which then has a negative impact on memory and learning (El-Shafey, 2012).

SLE patients often experience complications with such intellectual functions such as attention to details, memory, expressing their thoughts, decision making, or calculation (Lupus

International, 2011). These deficiencies may range from slight thought instabilities to more serious states of confusion and they can be quite worrying to the patient experiencing them and also for their caregivers since these problems are difficult to identify objectively (Lupus International, 2011).

Earlier neuroimaging studies have shown cognitive deficits in SLE sufferers and proposed that it may be linked to disturbed or injured brain white matter (WM) connectivity (Zhao et al., 2018; Lee et al., 2014). Further, the occurrence and degree of cognitive deficit is also uncertain, where more permanent brain injury has been linked to neural damage that might be as a result of diseases of the cerebrovascular system (Benedict et al., 2008). It has been predicted that roughly thirty three percent of SLE patients who have never exhibited signs of neuropsychiatric SLE will have noticeable cognitive deficits and about eighty eight percent of SLE patients who have had a prior neuropsychiatric episode displayed some level of cognitive challenges, probably due to some outstanding damage to the nervous system (Lupus International, 2011). The neuropsychological deficits associated with SLE include memory, visuo-spatial and visuo-constructional abilities, executive function (eg. planning, initiation and self-monitoring), visuo-motor coordination and speed. (Federman et al., 1998). In addition, neuropsychiatric symptoms include severe confusional state, headaches, depression and anxiety (Bhatt et al., 2007).

SLE and Psychological wellbeing

SLE is a pervasive condition which has an impact on physical, psychological and social well-being. Psychological well-being is about living life to the fullest; it is a combination of having good feelings and functioning well in all areas of life according to Huppert (2009). Emotional uncertainties are evident among people with SLE as they live with pain from the condition, fears about treatment, difficulty with performing chores/housework, side effects of medications, and unexpected disease flares (Mathias et al, 2018). A person's good

psychological health is therefore affected when negative emotions such as anxiety and depression sets in and last longer interfering with an individual's ability to carry out his or her daily routines leading to poor quality of life (Huppert, 2009). Studies have reported that chronic disease such as SLE, has a negative impact on some people, causing them to become depressed or anxious, some get tired easily and this affects their work. Waterloo et al., (2009) found emotional instabilities such as difficulties and uneasiness in social gatherings and depressive mood to be recurrent in people with SLE and these discomfort was linked to skin and joint abnormalities.

SLE and Quality of Life (QOL)

One's QOL may be affected by his /her perceptions, psychological state, physical health, social relationships and environment factors (Olesińska & Saletra, 2018). Health-related quality of life (HRQOL) is that facet of QOL that focuses on an individual's health; it also assesses other domains such as general wellbeing, psychological health, physical functioning, and social functioning. Concepts such as mood, distress and neuropsychological functioning commonly fall in these wider areas (Ware, 1994). QOL of SLE patients specifically HRQOL has been described by several studies where participants reported poor quality of life (Wang et al., 2001; Fortin et al., 1998; Gladman et al., 1996). Further, SLE has been reported to seem to have a bearing on all the various domains of HRQOL (Wang et al., 2001; Fortin et al., 1998; Gladman et al., 1996). A number of symptoms have been recounted in SLE; these might have diverse detrimental influence on their QOL.

Psychological wellbeing and cognitive function

A person's perception of wellbeing entails a blend of intellectual, somatic and social well-being that cannot be entirely explained by only the activities of a disease (WHO, 2001). Improved psychological health has been linked with enhanced mental function (Llewellyn et al., 2008).

An association was further found between cognitive decline in the areas of memory, executive function and language and depression among SLE patients (Kozora et al., 2007). Positive mental health has been defined as a state of health in which an individual acknowledges his or her strength, can manage life stressors, work efficiently and able to participate in the welfare of his society (WHO, 2001). Psychological well-being may lead to decreased stress (Steptoe et al., 2005) and enhancing neural efficiency (Scarmeas & Stern, 2003). Further, experimental evidence exist which proposes that inducing positive mood states in individuals increases their attention, other cognitive performance and also makes them to be more flexible and creative in their thinking over short periods (Ashby et al., 1999; Isen et al., 1991). Studies have reported depression and anxiety to be the prevailing complaint among SLE sufferers and also an association has been found to exist between mental processes and mood changes (Krysta et al., 2015). Petri et al., (2010) revealed that depression is associated with poor cognitive functions in SLE patients. Fredrickson and Branigan (2005) also concluded that positive mood helps individuals to generate more ideas. It can therefore be inferred that, individuals who are experiencing cognitive challenges may present with poor mental health. The purpose of this study therefore is to assess the neuropsychological functioning of individuals living with SLE using a mixed method approach.

Statement of the problem

SLE is an autoimmune condition with central nervous system link and includes a wide range of clinical manifestations of which about 30% to 40% are attributable to the condition (Hanly et al., 2007). SLE was previously believed to be rare among Africans in the sub Saharan regions but studies have disputed this assumption (Wadee et al., 2007; Tiffin et al., 2014). Further, an audit of cases seen in the Korle-bu teaching hospital in Ghana revealed higher than expected rates of people, mostly young women living with the condition (Dey et al., 2015). Majority of

the women are diagnosed during their reproduction years, a period in their lives when they are now considering starting their own families and beginning their careers. However, little information exist on the impact of SLE on their daily experiences (Russell & Gregory, 2000). Very little is known about the experiences of women living with lupus in Ghana.

Neuropsychological deficits are very common grievances expressed by SLE patients. Feeling that one cannot remember to do simple activities or daily responsibilities can be very frustrating, and may cause distress to family members and loved ones of the patient who may not fully understand their condition. This can also intensify feelings of depression and isolation. In addition, the effect of SLE on the CNS is one of the most significant causes of long term morbidity and reduction in quality of life of these patients (Jennekens & Kater, 2002). Cognitive dysfunction in these relatively young population affected by SLE, affects the quality of life and poses a challenge to clinicians as the cause has been difficult to clearly define (Murray et al., 2012).

It is estimated that approximately 26.9% of SLE patients who do not exhibit any sign of neuropsychiatric systemic lupus erythematosus (NPSLE) will have detectable cognitive deficits in addition to 52.2% of those with NPSLE (Monastero et al., 2001; Unterman et al., 2010).

SLE is related to various losses and changes such as limited activities, over reliance on caregivers, problems in relationships, body image, risk of miscarriage, unemployment due to physical disability, cognitive disorders, psychosis, delirium, and also central nervous system involvement which all serve as a source of discomfort for the sufferer (Cohen et al., 2004). Thus SLE patients and their families need emotional and practical adjustment; this adjustment may be influenced by the severity of their cognitive deficit.

To the researcher's knowledge, only one study has found in Africa which examined the neuropsychological functioning of SLE patients (e.g., Mani et al., 2015); none was found in Sub-Saharan Africa. Despite the reports on cognitive dysfunction in SLE, cognitive screening is not considered an integral part of clinical investigation of SLE patients in Ghana.

The present study examined the neuropsychological functioning of individuals living with SLE. Neuropsychological tests were administered to assess skills necessary for adequate daily living such as executive functions, abstract reasoning, learning and memory, visual-spatial skills, motor abilities and emotional problems. The quality of life of participants was assessed and a qualitative individual interviews was conducted to explore the lived experiences of patients.

Aim and objectives of the Study

The main aim of this study was to examine and understand neuropsychological functioning of individuals with SLE.

Specific objectives:

1. To examine the neuropsychological functioning in SLE
2. To investigate psychological functioning and quality of life of SLE patients
3. To examine the possible relationship between cognitive functioning and quality of life of SLE patients.
4. To investigate disease duration and its impact on quality of life of SLE patients.
5. To explore the lived psychological experiences of SLE patients and how the disease has affected the quality of their lives.

Relevance of the study

This study is beneficial to SLE patients in that it has provided insight into the variables capable of influencing the SLE individual's quality of life. The results of this study may lead to the development of interventions for the future management and treatment of neuropsychological deficits in SLE patients in Ghana. Further, early detection of cognitive deficits may lead to early intervention with better outcome and possibly prevent a more severe condition such as cerebrovascular disease.

Finding of the study may help clinicians, parents and caregivers of SLE patients acknowledge the neuropsychological changes associated with the disease and how they affect the quality of life and wellbeing of individuals. Through this research, SLE patients and their caregivers would appreciate the possible link between psychological distress associated with cognitive dysfunction such as forgetfulness and low concentration and the extent to which they affect patients' performance on tasks at work and home. This will enable caregivers and employers to understand these individuals better and encourage these patients to seek appropriate psychological interventions.

The study may also be relevant to rheumatologists in Ghana. With the findings of this study, rheumatologists are placed in a better position to consider referring these patients for neuropsychological assessment as evidence for the existence of an association between cognitive dysfunction and psychological distress in SLE will have several implications. If those with cognitive deficits show evidence for cerebral infarction, then treatment may be offered to these patients.

CHAPTER TWO

LITERATURE REVIEW

Introduction

This chapter is introduced by presentation of theoretical framework: Luria's model of brain functioning (1974) and Health Related Quality of Life (HRQOL); which were used to guide the study. Since this study was conducted among SLE patients, it is followed by presentation of literature concerning neuropsychological functioning. This chapter further introduces the rationale, hypotheses and research questions developed for the study. Finally, the proposed conceptual model and the operational definitions of terms in the study were explained.

Theoretical Framework

Luria's model of brain functioning: The Three Functional Units model

As has been previously mentioned, some studies have reported changes in the brain of SLE patients but much is not known about the neuropsychological changes involved. Therefore, this study sought to examine the neuropsychological changes in SLE patients focusing on the most appropriate neuropsychological clinical and experimental research. Luria's Three Functional Units Model (Luria, 1974), will be relevant to this study because it attempted to shed light on brain functioning.

Luria was the first author to conceptualize executive function which has its basis in neuropsychology. He described the human brain to comprise three basic functional units that are interconnected.

The First Unit comprises of structures of the brainstem, which include the thalamus, monoaminergic cells in the brainstem and the reticular activation system. They function by keeping the cerebral cortex alert and active, providing the brain with an even base for the organization of its different processes (Zaytseva et al., 2015).

The Second Unit is made up of the lobes (occipital, temporal and parietal lobes); its responsibility is locating, integrating, processing, and storage of sensory information from the environment.

The frontal lobe is the last unit and it is responsible for the selection, planning, implementation, and direction of a person's behaviour and its assessment. It also includes important cognitive processes such as awareness, insight and sustained attention (Luria, 1974; Cummings, 1995; Stretton, & Thompson, 2012).

According to Luria, any form of psychological action involves the concurrent interaction of all the units, and he emphasised that a patient's inability to accomplish a particular task may not necessarily indicate a dysfunction in a particular area of the brain. He argued that every behavioural task involves the synchronised and combined activity of different cortical areas, all functioning in different way to the enactment of the task (Zaytseva et al., 2015). Luria further postulated that problem solving techniques were dependent on the frontal lobe when he observed people with frontal lobe damage trying to solve a problem. He concluded that there are connections between the frontal lobe, problem solving and executive function (Garcia-Madruga, 2016). An injury to the frontal lobe can result in the inability of an individual to control behavioural consequences disturbance in complex behavioural programmes and an individual's ability to control behavioural consequences. Psychological functions are not restricted to a distinct locality in the brain, but are dispersed with each area of the brain participating in several functional systems, as confirmed by neuroimaging studies (Zaytseva et al., 2015; Tellez & Sanchez, 2016).

Luria's concept is viewed as an outline for the specification of cognitive functions and also for the development of neuropsychological tests (Zaytseva et al., 2015).

Jung et al., (2010) reported structural changes to the amygdala and hippocampus in SLE patients. These are structure in the temporal lobe responsible for memory and emotion. Usual

signs of temporal lobe dysfunction include personality changes, drastic changes in affect, memory problems, and at least a brief disturbance in language (Kolb & Wishwaw, 2009). Other studies have reported memory, visuo-spatial and visuo-constructional abilities, executive function (eg. planning, initiation and self-monitoring), visuo-motor coordination and speed as the neuropsychological deficits associated with SLE (Federman et al., 1998). Based on the reports above, deficit in one domain can affect functioning in other brain regions and the reverse is true. This suggests that SLE patients with structural changes are more likely to present with cognitive deficits such as attention, executive function, memory, language, and academic challenges. Therefore, it could be inferred that individuals with SLE are relatively likely to perform poorly on cognitive tasks compared to normal individuals or people with other autoimmune conditions.

The Health-Related Quality of Life (HRQOL) Theory (Wilson & Cleary, 1995)

‘The Health-Related Quality of Life (HRQOL) theory explains the quality of patient care in an ailment situation (Wilson & Cleary, 1995). Quality of life (QOL) is defined as the general outlooks, feelings, or the ability of persons to perceive an ultimate pleasure in a specific state of health; physical, mental or social (Doria et al., 2004). When an individual rates one domains of his life, for instance his physical domain as being significant to his overall quality of life, he or she would report poor quality of life when that aspect is threatened by an ailment or a disease. Five domains were identified: overall quality of life, physiological factors, symptom status, general health perceptions and functional status (Wilson, & Cleary, 1995). In addition to these factors, the individual’s personal characteristics and environmental factors may affect one’s placement on the range. These factors are essential as they could determine the general outcome of an ailment and an individual’s perception of quality of life.

Bonomi et al. (2000) observed that people with chronic conditions had significantly lower mean score on the various domains of quality of life as compared to healthy adults. Hence, the

study noticed discrepancies in various life situations like ageing, pregnancy states, and chronic illness as negative to a person's perceived quality of life. Regarding SLE, the disease is noted as a chronic autoimmune condition that affects various organs of the body, leading to serious complications which is likely to affect the quality of life of individuals (Tiffin et al., 2014). If an SLE patient rates his overall quality of life as dependent on his physical abilities but not able to go about his/her normal activities due to his condition, he/she might rate himself as having poor quality of life.

Review of Related Studies

Neuropsychological deficits in SLE

Cognitive deficits have been reported in SLE, even among individuals without any history or obvious symptoms of central nervous system (CNS) involvement (Unterman et al., 2010). Probably, cognitive deficits may have resulted from an underlying CNS disease where the exact mechanisms is yet to be clarified. Also prevalence and degree of cognitive impairment is uncertain (Benedict et al., 2008).

Butt et al. (2017) examined the occurrence of cognitive complications in 43 Pakistani natives diagnosed with SLE. Cognitive dysfunction was defined as score below 26 on the Montreal Cognitive Assessment tool (MOCA). Results showed cognitive dysfunction in 65.1% of patients. Further, 60% and 74.1% of the respondents who have lived with the disease for more than two years, as well as participants with less than twelve years of formal education respectively reported cognitive deficits.

Leslie and Crowe (2018) reviewed studies on cognitive functioning in systemic lupus erythematosus patients. Meta-analytical techniques were used to analyse the data. The results supported the opinions that SLE (irrespective of obvious neuropsychiatric involvement) was related with statistically noteworthy deficits in visual reasoning, visual attention, cognitive fluency and immediate visual memory compared to healthy controls. Furthermore, the results

supported cognitive disturbances in SLE with considerably greater cognitive deficits in NPSLE patients compared to non-NPSLE patients.

In Japan, Nishimura et al. (2015) assessed neurocognitive impairment (NCI) in 43 Corticosteroid-naive Patients with Active SLE who had no past or current history of neuropsychiatric disorder and 30 healthy controls with similar characteristics. Results revealed that 12 of the SLE patients and 2 controls had NCI. Further, the SLE Patients showed significant deficits compared to the controls on tasks measuring complex attention/executive function, immediate recall, and psychomotor speed. The test of psychomotor speed was reported as the feature that best distinguished the 2 groups.

Utset et al. (2006) examined neurocognitive dysfunction in 50 disabled SLE patients in the United States and concluded that the two indicators that may contribute to work disability in lupus patients is neurocognitive dysfunction and fatigue. Other related factors identified include SLICC Damage Index scores, low education levels, discoid lupus, nephritis, and possibly African-American race.

In Canada, Hanly et al. (2010) examined cognitive function in 68 people living with SLE; 33 Rheumatoid Arthritis patients (RA), and 20 patients living with Multiple Sclerosis (MS) using the Automated Neuropsychological Assessment Metrics (ANAM) and compared their results to 29 healthy controls. Findings revealed that the control participants performed better than the various groups. Further, 50% of SLE patients, were reported to show deficits on at least one domain of the test and 11% showed impairment on 4 or more subtests.

In Canada, Denburg et al. (2008) assessed cognitive impairment in eighty six females with SLE. The participants were grouped according to past or present history of neuropsychiatric (NP) symptoms (inactive, active, or Never) and were compared to 35 healthy women on a wide-ranging battery of neuropsychological tests assessing various cognitive domains. Results indicated that SLE patients present with a range of cognitive deficits. Further,

no relationship was observed between cognitive deficit and emotional disturbance. Also patients with active NP symptoms showed deficits similar to patients with resolved NP symptoms. NP-SLE patients showed significant deficits compared to controls on several summary scores.

Glanz et al. (1997) examined the pattern of neuropsychological dysfunction in patients with inactive SLE sampling Fifty-eight subjects with inactive SLE and 47 healthy controls. Cognitive deficit was determined by comparing scores on a neuropsychological battery patients premorbid estimates of cognitive functioning. Results showed that 43% of patients with inactive SLE and 19% of healthy controls showed cognitive deficits. The healthy controls performed better than the patients with inactive SLE on tests assessing visuo-spatial memory, auditory verbal memory, psychomotor speed and motor functioning. Further, age was found to influence the cognitive deficits reported in the patients with inactive SLE. Finally, no relationship was observed between cognitive functioning and current depressive symptoms.

In Egypt, Mani et al. (2015) focused on memory and learning functions in 40 SLE patients and 40 sex and age matched controls. Results showed deficit in verbal and visual memory in the SLE group relative to controls. Further, it was reported that the SLE patients displayed poor memory function, but their learning slope compared to the controls was similar.

Phuti et al., (2018) qualitatively examined the experiences and perceptions of 25 South African women living with SLE. Detailed interviews were carried out to explore a variety of HRQOL experiences including emotional health, pain, weariness, sexual well-being and fertility. Results revealed that patients experience physical and psychological distress. The most common complaint of patients is pain which has a detrimental effect on their daily lives, social lives and relationship with loved ones. Further it was reported that patients have difficulties explaining their experiences to people. It was further reported that patients used spiritual coping as a way of dealing with their challenges.

Psychological wellbeing and quality of life in SLE

Wu et al. (2016), assessed the quality of life of ninety four Taiwanese diagnosed of SLE. The aim of their study was to use a path analysis to confirm recommended predictive models of quality of life for people with SLE. The participants provided a self-reports of their current fatigue levels, level of pain, sense of competence, depression, anxiety, environmental effect and overall quality of life. The result showed that disease severity was associated with the patients' perceived quality of life. Further, depression, patient's sense of competence, anxiety fatigue and pain, were found to impact patient's quality of life both indirectly and indirect.

Shakeri et al. (2015) examined the occurrence of depression and anxiety among Iranian SLE patients and also determined their health related quality of life (HRQoL) and compared them to healthy controls. SLE related variables, psychosis and history of seizure were noted. Further, Beck Anxiety and Depression Inventory and the short-form 36 Health Survey were administered to participants. Results revealed no statistical significant between the SLE patients and healthy controls on anxiety and depression. Further, among the SLE patients, more severe anxiety and depression were reported.

Williams et al. (2014) examined Stress and Depression in Relation to Functional Health Behaviours in 30 African American Patients with Systemic Lupus Erythematosus in the United States. Results showed that reported stress levels had great effects on functionality, predominantly between health distress and functionality. Further, it was reported that symptoms of depression had moderately affected role limitations and hospital admissions.

In the United States, North Carolina, Somers et al. (2012) assessed self-efficacy, pain catastrophizing and psychological distress among seventy four SLE patients. Results showed a relationship between psychological distress, respondent's physical symptom reports and self-efficacy for pain control and pain catastrophizing. Further, participants with intense stiffness,

pain and fatigue recorded low scores on self-efficacy for pain management even after disease duration, disease activity, age and race were controlled for. Patients who stated that they have very low positive mood obtained scored higher on pain catastrophizing.

Jarpa et al. (2011) examined 26 common mental disorders and psychological distress in Eighty-three Chilean SLE patient. Findings revealed psychiatric diagnoses in 44.6% of patients; major depressive episode (MDE) was observed as the most frequent (21.7%). Further, no relationship was observed between a DSM-IV diagnosis of MDE and disease activity in the participants. Furthermore, anxiety (15.6%) or mood disorders (28.9%) were present in the 42.2% of the patients with NPSLE.

Petrus and Chan (2008) assessed the influence of a group activity on the psychosocial functioning and self-esteem of 56 individuals living with SLE. The participants took part in a two and a half hour weekly psychosocial group session for six weeks. They were equipped with information and skills to adjust to the demands and the stress brought about by the disease, skills to increase their confidence and to develop a positive outlook toward the condition. Participants were assessed on the General Health Questionnaire (GHQ) and Rosenberg's Self-esteem Inventory before and after the sessions. Results revealed that participants scored higher on the GHQ and self-esteem after the sessions.

Kozora et al. (2006) studied depression, fatigue, and pain in 31 NPSLE patients, 22 non NPSLE's and 25 healthy controls. Results revealed greater pain, greater depressive symptoms, advanced levels of tiredness and more perceived cognitive challenges among the SLE group.

McElhone et al., (2006) swotted 53 studies published in the 1990's to 2005 reporting on health related quality of life (HRQOL) of adult SLE patients. Findings revealed that SLE patients reported low HRQoL; HRQoL was also not found to be associated to disease activity; further, age had a negatively influence on HRQoL specifically physical health but the effect of disease duration on quality of life was not clear.

Keller (1999) examined physical stress, social support and psychological distress in 93 Women with SLE. Results showed that high psychological distress was associated with high levels of illness-related physical stressors. Further, functional disability and satisfaction with social support was observed to significantly predict psychological distress.

Rationale of the study

The literature shows that considerable attention has been paid to assessing the CNS challenges that comes with SLE and its impact on the patient's wellbeing. However, there are still some gaps that still need further empirical examination. For instance, most studies that actually looked at neuropsychological functioning of SLE patients were studies done in the western world and Asia. Only one study was found in Africa and none in Sub Saharan Africa to the best of the researcher's knowledge that actually examined cognitive functioning of SLE patients (Mani, et al., 2015). No study has been conducted in Ghana considering these constructs in SLE patients.

Again, in the studies reviewed, the behaviour measures used assessed only depression and anxiety (Glanz et al., 1997, Shakeri et al, 2015), disregarding other psychological disorders that may be present or associated with SLE. In the current study, the Brief Symptom Inventory which measures other forms of distress aside anxiety and depression was used to assess psychological distress in the participants.

Additionally, most of the studies reviewed used few measures in their assessment (Mani et al., 2015; Butt et al., 2017). For instance Mani et al. (2015) used only the Montreal cognitive assessment which is a screening tool to assess cognitive deficit among SLE patients. The Rey complex figure which assesses memory (immediate, short and long term memory), visuo-spatial abilities, Trail Making Test which assesses executive function, and the Cognitive failure questionnaire were added to the cognitive tools in this study so as to effectively assess the various cognitive domains.

Almost all the studies reviewed employed either a qualitative or a quantitative approach.

Therefore, the current study employed an explanatory sequential mixed method design so as to be able to better understand and explain the findings of the study.

Finally, this study serves as a link between other researches internationally with that of Ghanaian samples. It has further provided data on SLE patients in Ghana and serves as a starting point for other future researchers.

Statement of Hypotheses for Quantitative part

Hypothesis 1: SLE patients will obtain lower scores on neuropsychological measures compared to healthy controls in the following domains;

- i) Attention and executive function
- ii) Memory
- iii) Psychomotor speed/ visuospatial and constructional abilities
- v) Verbal fluency

Hypothesis 2: There will be a statistically significant difference between SLE patients and Health controls on the behavioural measure and quality of life.

Hypothesis 3: There will be a statistically significant positive relationship between neuropsychological functioning and quality of life of SLE patients.

Hypothesis 4: SLE patients who have lived with the condition for more than two years will have better quality of life compared to newly diagnosed.

Research Questions for Qualitative

What are the lived psychological experiences of SLE patients?

- a) What are the challenges that SLE patients encounter?
- b) What are the supports that SLE patients receive?

2 What are the coping mechanism employed by SLE patients?

Proposed Conceptual Model for the Quantitative Part of the Study

The figure below shows the proposed conceptual framework of the study's hypothesized findings. The figure indicates expected significant relationships between the variables under study. SLE is expected to affect cognitive, behavioural functioning, and quality of life of patients. It is expected that there will be a significant positive relationship between cognitive function and quality of life and also between behavioural functioning and quality of life. Again, variables such as age of respondents, duration of disease and years of education will moderate the relationship between cognitive functioning and quality of life.

Figure 2.1: Proposed Conceptual Framework

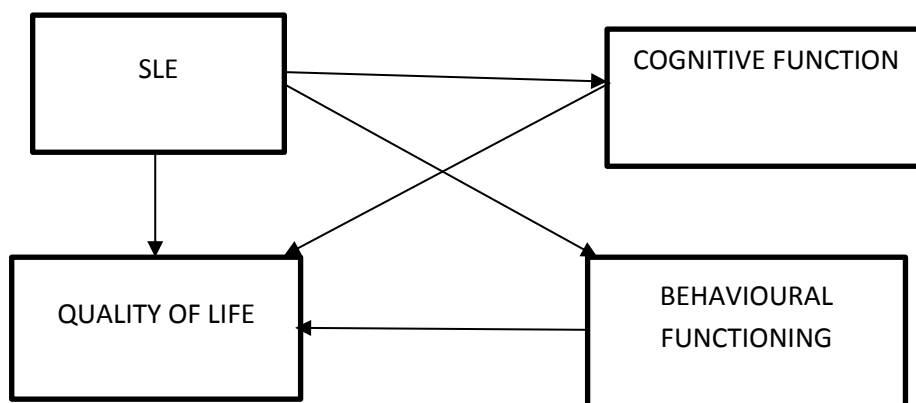

Operational Definitions

Adult: An individual above 18 years of age.

SLE Patients: Individuals diagnosed clinically with systemic lupus erythematosus

Psychological well-being: It is one's perception about his or her mood.

Cognitive functioning: Skills related with memory, executive functions, attention, visuospatial skills/ visuomotor and verbal fluency.

Quality of Life: It is the general and specific views a person holds about how his or her Life is.

Healthy controls: individuals who have no known medical condition.

Newly diagnosed: SLE patients who have lived with the disease for less than two years.

CHAPTER THREE

METHODOLOGY

Introduction

This section examines the method employed by this study. The study was in two phases; study one was a quantitative study and study two employed a qualitative approach. Information on the setting, population, sample size, participants, sampling technique, research design, measures, ethical considerations and the procedure used for the study is presented in this section.

Research Design

The research primarily employed a mixed method design, specifically the explanatory sequential mixed method design which employed two different data collection times; the quantitative data was collected first before the qualitative (Hughes, 2016). The first phase was a quantitative study which involved the use of questionnaires to gather information from participants on cognitive, quality of life and psychological wellbeing. The second phase was a qualitative study which involved “one on one” interview with participants. Mixed-method approach was used because of its effectiveness in tackling potentially unexplained psychological issues in diverse socio-cultural contexts (Creswell, 2013). Further, the researcher is interested in finding the relationship between the variables under study and also to understand how individuals with SLE cope with their symptoms, and their quality of life so a mixed method would expand the breadth and range of inquiries and strengthen the study’s conclusion (Greene, 2007).

Sampling Technique and Sample size

In the current study, a sequential design using the nested sampling technique developed for mixed-method studies was used (Onwuegbuzie & Collins, 2007). A nested technique is one

method of sampling for a sequential mixed-method study. It suggests that a small group of people are selected from the sample that participated in the first phase of the study to be participants in the second phase (Onwuegbuzie & Collins, 2007). In the current study, a subset of participants in the quantitative study were selected for the qualitative.

In selecting the participants for the study, different sampling techniques were used. The purposive sampling technique was used in recruiting participants for the quantitative part of the study so that needed participants were selected for the quantitative study. The sample was based on who was appropriate because of the specialized nature of the study. Further convenience sampling was employed for the qualitative so that those who were available and were willing to participate were recruited. Different sample size determinations were used in deciding how many people were sampled for each phase of the study. Outlined below are how both the quantitative and qualitative studies were conducted.

Study 1: Quantitative Study

Research Design for the Quantitative Study

The quantitative section of the study was conducted using survey method in the data collection process. This method involved the administration of questionnaires to samples of the desired population. The questionnaires comprised instruments that measured quality of life, psychological distress, cognitive screening, attention and executive function, memory, verbal fluency, and visuospatial/ constructional skills

The choice of the survey technique was appropriate for this study because it allows for larger data set to be collected.

Study setting

The quantitative study was conducted at the department of Rheumatology of the Korle Bu Teaching Hospital in Accra. This Unit was chosen because it is the main referral unit for all SLE cases in Ghana. The Rheumatology department renders outpatient, inpatients and day care services to patients with a wide range of rheumatological disorders.

Population and sample for the Quantitative study

The population comprised SLE patients receiving treatment at the Korle-bu Teaching Hospital Rheumatology Unit. The Unit has over 700 patients with various rheumatic conditions in its database over a four year period with about 150 being SLE cases. Study population include consenting adult patients both newly diagnosed and already diagnosed of systemic lupus erythematosus. The sample for the study comprised 70 SLE patients, all 18 years and above receiving treatment at the Korle-Bu Teaching hospital, Accra, Ghana and 65 healthy subjects were included as healthy controls also 18 years and above with no known medical condition. In sum, 135 respondents were recruited for the quantitative study. The sample size was determined to be adequate using Tabachnick and Fidell (1996) formula for calculating the minimum sample size for multivariate analysis. The formula $N > 50 + 8M$ (where M = number of IVs) was used. There were two main groups of interest; SLE patients and healthy controls. Therefore, there were two main independent variables and the minimum number of participants required was $N > 50 + 8(2) = 66$. The sample of 135 participants thus 70 SLE patients and 65 controls was therefore adequate for the current study.

Inclusion and Exclusion Criteria

Participants' selection criteria was based on the following criteria for the SLE patients:

- Persons 18 years and above with no neurological condition
- Had met the clinical medical diagnosis for SLE and have consented to be part of the study.
- Could read and write in order to complete the tests.

For the healthy controls

- Persons 18 years and above with no past or current history of a medical condition and are willing to participate in the study were recruited.
- Could read and write in order to complete the tests.
- **Exclusion criteria**

SLE patients with known history of the following:

- Neurological disease.
- Major psychiatric disorder.
- Alcohol/drug abuse.
- Diabetes mellitus.
- Uncontrolled hypertension.
- History of renal/pulmonary disease.
- Had a history of head trauma/ traumatic brain injury.
- Stroke

Healthy controls

- People with any current or past history of a medical condition were excluded.
- Had a history of head trauma/ traumatic brain injury.
- Had an alcohol, drug and addiction/dependence.

Measures

The Systemic Lupus Erythematosus Disease Activity Index (SLEDAI) was developed and validated as a clinical index for the measurement of disease activity in SLE and has been used as a global measure of disease activity in SLE since its introduction in 1985. The index has been used successfully and has been shown to be valuable in both research and clinical settings (Gladman et al., 2002). An appropriate SLEDAI score to define active disease is 3 or 4. It has a high internal consistency with Cronbach alpha of 0.89.

Montreal Cognitive Assessment (MoCA) (Nasreddine et al., 2005)

It is a screening tool for cognitive dysfunction assessing 8 domains namely, attention and concentration, executive function, memory, language, visuoconstructional skills, conceptual thinking, calculations and orientation. It takes approximately 10 minutes to administer the test. The total possible score is 30 points with score of 26 or above as normal. It has a high internal consistency with Cronbach alpha of 0.83.

Wechsler Adult intelligent Scale [WAIS] (Wechsler, 1981; Wechsler, 2008).

This is an intelligence test developed by David Wechsler to measure the intelligence among older adolescents and adults. The current revised edition comprises of 10 main subtests and 5 supplemental subtests (Wechsler, 2008).). The digit span subscale was used in this study. The WAIS is a well-established scale and it has fairly high consistency, it has a reliability ranging from 0.70(for 7 subscales) to 0.90 (2 subscales).

Digit Span Subtest of the WAIS IV (Wechsler, 2008)

This test assesses attention, it measures both auditory attention and span of immediate verbal memory recall (Lezak et al., 2004). It has three level (forward and backward and sequencing). Each level (number of digits) has two trials with dissimilar series of numbers. If the subject fails both trials at a given level, the test is discontinued. The subject receives two score if he gets both trials correct at a given time. This study selected two part of the test; Digit span forward and Digit span backward. Each test section consists of seven sets of random number sequences which enables the examiner to read out a series of numbers to the examinee. The examinee is expected to recall the numbers in the same order in which they were given (Forward) or repeats them in the reverse order of presentation (Backwards) after the full series is read. The participant scores one point for each trial he/she passes. The maximum score on each subtask (Digit Forward and Digit Backward) is 14 (two trials for each of seven levels).

Spatial Span subset of WAIS III R (Wechsler, 2008)

Spatial Span assesses visuospatial working memory capacity. It has two level (forward and backward). Examinee taps a series of blocks as demonstrated by the examiner. With Spatial Span Forward, examinees are expected to tap the blocks in the same order as demonstrated by the examiner and to do the reverse for backwards. The participant scores one point for each trial he/she passes. The maximum score on each subtask (Forward and Backward) is 14 (two trials for each of seven levels).

Rey-Osterrieth Complex Figure Test [ROCF] (Rey & Osterrieth, 1944)

This test was constructed by Rey in 1941 as test for visuospatial abilities and memory. It was later enhanced by Osterrieth in 1944. This test also involves planning, organizational abilities, and problem-solving schemes (Strauss et al., 2006). The patient is told to copy the design on a plain drawing paper of 8 ½ x 11-inch size. Time limit needed for the patient to draw a complete

figure is within five minutes. After the copy, the participant is asked to draw the figure again from memory (immediate recall). After a 30 minute interval, the patient is called upon to construct the same figure from memory (Delayed recall). The subject's overall score is based on the precision of eighteen constituents of the figure. Scoring of each constituent score ranges from 0 to 2 with the highest possible score of 36 (Strauss et al., 2006). It has a Cronbach alpha ranging from .76 to .89.

The Cognitive Failures Questionnaire [CFQ] (Broadbent et al., 1982).

This is a 25-item questionnaire that was designed by Broadbent and colleagues in 1982 to measure an individual's likelihood of committing an error in the accomplishment of an everyday task. Items on CFQ evaluate a general factor of cognitive failure that comprises; perception, memory, and motor function. An example of questions on CFQ is —Do you drop things? which may be rated on a 5-point Likert-type scale [0 = never, 4 = always] (Broadbent et al., 1982). The total possible score is 100 points. The Cronbach's alpha for the CFQ was found to be 0.91, with a test-retest reliability of 0.82 over an interval of 2 months (Vom Hofe et al., 1998).

Brief Symptom Inventory [BSI] (Derogatis, & Melisaratos, 1983)

The BSI is a 53-item self-report instrument designed to screen for symptoms of psychological distress in medical, psychiatric and healthy individuals alike. It is a short version of the Symptom Check List-90-R. It assesses nine domains of key symptom areas and three global dimensions of psychological distress. It is a 5-point Likert scale, from 0 = —not at all, to 4 = —extremely. Sample questions for example includes... —Nervousness or shakiness inside... The subscales of the BSI's measures numerous dimensions of psychological dysfunctions. The Global severity index (the total score on the scale) is obtained by adding up all the items under all the subscales and dividing it by 53 (the total number of items on the scale). These subscales

include the following item summations Depression (Items 9, 16, 17, 18, 35, 50), Obsession-Compulsion (Items 5, 15, 26, 27, 32, 36), Anxiety (Items 1, 12, 19, 38, 45, 49), Interpersonal Sensitivity (Items 20, 21, 22, 42), Hostility (Items 6, 13, 40, 41, 46), [Somatization (Items 2, 7, 23, 29, 30, 33, 37), Phobic Anxiety (Items 8, 28, 31, 43, 47), Paranoid Ideation (Items 4, 10, 24, 48, 51) and Psychoticism (Items 3, 14, 34, 44, 53). The BSI has a high Cronbach's α that ranges from 0.71 to 0.85 (Derogatis, & Melisaratos, 1983).

California Verbal Learning Test-Second Edition Short Form [CVLT-II SF] (Delis et al., 2000)

This is a verbal memory test, intended to measure the use of semantic associations as a means of learning words. The CVLT-II Short Form has a category lists of words, —List-All. The List contains names of fruits, clothing and tools. Presentations of items are done in a randomized fashion with instructions to recall the words in any sequence. This is done in order to assess the subject's use of spontaneous semantic associations (Lezak et al., 2004). Scoring is done by summing the responses on a trial 1-4 (free recall), short delayed free recall, and long delayed free recall. Reliability score for CVLT-II Short Form given by the authors are high (Delis et al., 2000), with a split-half reliability of 0.87 to 0.89 and alternate form reliability of 0.72 to 0.79 for all the measures.

The Trail Making Test [TMT] (Reitan & Wolfson, 1985)

The Trail Making Test (TMT) is an executive function test which measures speed processing, sequence alternation, cognitive flexibility, visual search, motor performance and complex attention (Lezak, Howieson & Loring, 2004). TMT consist of a two part test, A and B. To administer this test, the subject is asked to draw lines to join successively numbered circles on Part A work sheet. Part B consists of numbers and alphabets and the participant is expected to link up the numbers and alphabets with a line. The first number, linked to the first alphabet and so forth. This executive function test measures areas of visuomotor skill and speed, attention

and cognitive flexibility. Scoring is based on the total time spent on completing both part A and Part B, including the time used to identify mistakes and corrections by the participants. Scoring is based on the total time spent on completing both part A and Part B, including the time used to identify mistakes and corrections by the participants. The time spent on part A is subtracted from the time spent on part B to determine the total time spent. TMT has a moderately high reliability coefficient of 0.60 (Spren & Strauss, 1998).

Controlled Oral Word Association Task (COWAT/ FAS, Benton et al., 1983)

Controlled Oral Word Association Test, (COWA or COWAT), is a verbal fluency test, it assesses unprompted production of words within one minute (Espe-Pfeifer & Wachsler-Felder, 2000). The test can be administered to both children and adult populations. The participant is usually asked to name words beginning with a letter, excluding proper nouns, the same word with different endings, for one minute and this procedure is repeated three times. The most common letters used are FAS or CFL (Semrud-Clikeman, & Ellison, 2009). The examiner must quickly write down the words provided by the participant on a piece of paper. The whole examination usually takes 5–10 minutes. The test recorded a cronbach alpha of .83 (Ruff et al., 1996). Scoring is done by summing the correct words under each alphabet presented. The global total is obtained by summing all the total correct words and dividing the total by 3.

Quality of Life (Spitzer, 1981)

The Spitzer's Quality of Life (SQOL) is a general Quality Of Life instrument that assesses five dimensions of quality of life (outlook, health, daily living, activity, and support of family and friends). It was used by doctors to evaluate the relative benefits and risks of various treatments for serious conditions and of supportive programs such as palliative care. It is one of the earliest QOL instruments to measure psychological wellbeing, activity level, and social support. It has five items and its range of scores is 0–10. The QOL measure has been used among people with

chronic physical conditions and cancer patients. Assessment of internal consistency demonstrated a high coefficient (Cronbach's $\alpha = 0.775$) and the interrater Spearman rank correlation was high and statistically significant ($\rho = 0.81, P < 0.001$).

The above measures were selected because the researcher sought to examine the various cognitive domains and each measure assesses a specific domain.

Procedure

Ethical approval to conduct the research was obtained from the Ethical Committee for Humanities (ECH) in the University of Ghana. After the approval, a letter of introduction was obtained from the Department of Psychology of the University of Ghana which was forwarded to the Hospital administrator, Korle Bu teaching Hospital, for the purpose of obtaining permission to conduct the research. This fulfilled the ethical requirements for institutional approval and informed consent.

After the ethical approval was given, a pilot study was first conducted to assess the ability of the instruments to produce the right responses. Through the pilot study, any challenge(s) with the instruments were corrected before going on with the main study. The main study commenced after the pilot.

Piloting the quantitative instruments

After the ethical approval, the quantitative questionnaires were first piloted. The piloting of the instruments involved a survey of 20 participants comprising 10 SLE patients and 10 healthy controls on which 19 were females and 1 male. The data was analysed using statistical package for social sciences (SPSS) software version 23. Reliability analysis done on the scales showed high Cronbach Alphas for all the scales.

Quantitative phase

The main study began after the pilot study. The researcher purposively select Systemic Lupus Erythematosus patients as the research participants. Data was collected by the use of questionnaires at the first phase of the study.

Ethical Consideration

High ethical standards were maintained during the data collection. First of all, the nature and purpose of the study was explained to the participants. The informed consent form was filled by participants who consented to partake in the study. Further, participants were informed of the voluntary nature of the research and their right to withdraw at any point in time without explanation or penalty. They were also assured of their privacy and confidentiality and that information will only be released to their attending physician if they agree that this is done. After the study, the researcher addressed any other concerns that participants had about the study in the form of debriefing.

A structured questionnaire was used to assess demographic characteristics including age, gender, ethnicity, religion, educational level, occupation, income and marital status, Further, clinical information and other history was obtained via a questionnaire. SLE disease duration, family history, alcohol use and smoking information were also taken. Furthermore, the records of all the patients were reviewed and all known risk factors (history of hypertension, heart disease, diabetes, hyperlipidemia, cigarette smoking) were noted.

Quantitative Data Analyses

Following the completion of the questionnaires administered, the responses were statistically analysed in line with stated hypotheses and with the aid of computers with SPSS programme. Following the assumptions required for the selection and usage of parametric test, the hypotheses were tested using the Multivariate Analysis of Variance (MANOVA), Standard

multiple regression and Independent T test. Standard multiple regression was used because the researcher wanted to assess any possible relationships between quality of life and the cognitive tests. This is because the researcher wants to determine the relationship that exists between the cognitive function of SLE patients and their quality of life which was measured on an interval scale. MANOVA was used to establish the difference between the SLE patients and the healthy controls on all the cognitive tests, psychological measure and quality of life. Lastly, the Independent t test was used to establish within group difference on quality of life of the SLE patients. Further information on quantitative data analysis are provided in chapter 4.

Study 2: Qualitative study

Research design for Qualitative study

The Qualitative method was chosen as an explanation method for the study because the issues being explored will give the researcher a better and in-depth understanding of the findings in the quantitative (Creswell, 2003). This requires in-depth engagement and discussions with the SLE participants on their psychological functioning and their quality of life. Qualitative approach offers the opportunity for such profounder exploration of the psychological changes in people with chronic conditions such as SLE and how that affects their quality of life. Further, this approach exposed the researcher to some coping strategies employed by these people.

In-depth individual interviews were used for collecting data in this phase. In qualitative research, In-depth interviewing comprises collecting data through individual interviews with a small number of respondents to explore their viewpoints on a particular situation, idea or program (Creswell, 2013). In-depth individual interview was chosen above other methods of gathering qualitative data such as focus group discussion because the researcher wants detailed information about the functioning and coping of the participants.

Qualitative Sample

Several factors were taken into consideration in determining the sample size for the in-depth interviews. Factors include issue being explored, the kind of participants needed for the study, budget or resources available for the study, etc. (Morse, 2000; Ritchie et al., 2003).

Additionally, saturation is used as a principle in determining the sample size of individual in-depth interviews (Mason, 2010). Saturation point in qualitative research according to Mason, (2010) is collecting information from participants until no new information is coming up. However, Creswell (1998) suggested a sample size of 5-25 for phenomenological studies, and Morse (1994) also proposed at least six participants.

A total of 11 respondents were interviewed for the qualitative part of the study. Majority of the participants interviewed were females.

Measures and Instruments for qualitative study

For the qualitative study, an individual in-depth, interview was conducted with 11 SLE patients using semi-structured interview guide with open-ended questions exploring the experiences and coping strategies employed by SLE patients. The semi-structured interview guide allowed for the same questions to be posed to all participants and probing questions to further explore the issue. Interviews were audio- recorded, transcribed, and analysed for themes. However, paper and pen was also used to record data from participants who did not want to be audio-recorded. Interpretative phenomenological analyses was used to analyse the qualitative data.

The Pilot Study for qualitative study

After the quantitative data analysis, the pilot study was conducted to assess the interview guide for the qualitative. A total of four (4) participants, all SLE patients were interviewed. The pilot interviews were transcribed and analysed to assess how well the interview guide produced the

needed information. The questions on the interview guide was able to elicit the information needed except that the researcher had a little challenge with regards to using the same words for the same questions when they were to be translated into “Twi” for the two participants who preferred to speak Twi. This challenge was dealt with before proceeding with the main study by recruiting respondents who were conversant with English language.

Qualitative Study

Just like the quantitative study, the qualitative study was conducted after the pilot study. Data was collected in Greater Accra since all the patients receive treatment at the Korle bu teaching hospital.

Qualitative Data Analyses

Thematic analysis was used to analyse qualitative the data. Braun and Clarke (2006) define thematic analysis as “a method for recognising, analysing and reporting patterns within data”. Their framework for thematic analysis involves familiarizing with the data, generating codes, categorizing themes, revising themes, describing themes and putting the analysis into writing. As suggested by Braun and Clarke (2006), developing main and sub themes from a data, could be based on either the research question or a theory. As such themes and sub-themes developed from the data gathered from the individual interviews were established on the research questions of the study and not theoretically based. Thus, themes that emerged repeatedly were documented and categorized, reflecting issues linked with the research questions for the study. This approach was used because of the flexibility it offers in analysing the qualitative data (Braun & Clarke, 2006).

Trustworthiness of Qualitative findings

The issue of trustworthiness of the qualitative findings was addressed based on the following standards suggested by Shenton (2004). Internal validity (credibility), was ensured by selecting only participants who were genuinely keen to participate in the study. Also, there was a frequent use of probes to produce comprehensive data and create understanding as well as develop meanings related to the research questions. All the interviews were audio recorded (with permission from participants) and transcribed for analyses. Supervisors provided different perspectives which aided in the development of the study. Three people helped with the transcription of the interviews. They were Mphil students with background in psychology and qualitative research methodology. Furthermore, the findings from the current study were supported by existing literature from SLE researches. Finally, the issue of (reliability) dependability was ensured by reporting in detail the research design used to enable replication of the study.

CHAPTER FOUR

RESULTS

Introduction

The current study basically sought to examine the neuropsychological functioning of patients living with Systemic Lupus Erythematosus in Ghana. The study combined a mix of quantitative and qualitative methods sequentially to understand and better explain the functioning of the patients under study.

Study 1 (the quantitative part of the study) tested some hypotheses regarding the cognitive and psychological functioning of SLE patients and how that affects their quality of life. Further, the diseased samples were compared to healthy controls on the cognitive measures to find out whether there are any differences between the two. Four fundamental objectives were addressed here: (i) examined the neurocognitive functioning in SLE compared to healthy controls (ii) investigate psychological functioning and quality of life of SLE patients (iii) assessed the impact of cognitive and psychological functioning on quality of life of individuals and (iv) examined disease duration on quality of life of SLE patients in Ghana.

Study 2 (the qualitative component of the study) had two fundamental objectives; (i) explored the lived experiences of SLE patients in Ghana and (ii) explored how SLE patients cope with the condition to have a better quality of life.

This chapter presents detailed findings from both the quantitative and the qualitative aspects of the study. The findings from study 1 (the quantitative component of the study) are presented first since this was carried out first, followed by findings from study 2 (the qualitative component). After this, a chapter summary is presented that summarizes all the findings from both the quantitative and the qualitative phases.

Study 1: Quantitative Results

This section presents analysis and results of the quantitative data. Preliminary analyses were first conducted before testing the hypotheses of the study.

Preliminary Data Analysis

This segment contains all preliminary analyses conducted on the data to prepare the data for analyses to test the hypotheses. Among the preliminary analysis conducted, the reliability of the scales, normality of the data distribution, group differences on the variables measured and demographic characteristics of participants were checked.

Descriptive Statistics, Normality and Reliability of Variables

The reliability levels of the scales were analysed using Cronbach alpha coefficient. According to Tashakkori and Teddlie (2010), a reliability coefficient above 0.70 is desirable for a scale to be considered reliable. After assessing the reliability of the scales, the normality of the data was also examined using skewness and kurtosis by running descriptive statistics. According to Tabachnick and Fidell (2007) a data is said to be normally distributed when the skewness values lie within the range of between +1.00 and -1.00 and the kurtosis values lie within the range of between +2.00 and -2.00. Table 4.1 shows the summary of the preliminary analyses of the data.

As shown in Table 4.1 below, the Cronbach alpha coefficient values of most of the tests range between $\alpha = .760$ and $\alpha = .934$ with only two instruments recording values below .7. This means that majority of the scales used had high reliability levels. The skewness values also lies between -.287 and 2.45 and the kurtosis values lie between -.150 and 11.54. According to Pallant (2011), many instruments and scales used in the social sciences have scores that are skewed, either positively or negatively. Pallant further stated that getting skewed scores does not certainly mean that there is a problem with the measure, but rather it reflects the underlying

nature of the construct being measured. Further, the standard deviation for some of the measures are high. This is because the data is heterogeneous and also some of the instruments are measured in second such as the Trail Making Test. Timing in seconds is required to determine the level of cognitive deficit so the 64.53 recorded in table 4.1 is in seconds which is equivalent to 1minute 4 seconds and 53 milliseconds which is lower but for analysis and interpretation, the data was recorded in seconds.

Table 4.1: Summary of Means, SD, Reliability, Skewness and Kurtosis of Variables

| Instruments | M | SD | A | Skewness | Kurtosis |
|--------------|-------|-------|------|----------|----------|
| MOCA | 24.66 | 4.121 | .762 | -1.102 | 1.335 |
| CFQ | 30.69 | 14.47 | .921 | .795 | 1.030 |
| QOL | 9.49 | .888 | .447 | -1.717 | 2.213 |
| BSI | .489 | .476 | .934 | 1.908 | 4.905 |
| CVLT | 24.15 | 5.179 | .822 | -.287 | -.543 |
| REY | 22.89 | 8.169 | .766 | -.758 | -.150 |
| TRAIL | 65.47 | 64.53 | .831 | 2.45 | 7.856 |
| DIGIT SPAN | 15.80 | 3.32 | .760 | .118 | -.275 |
| COWAT | 13.98 | 5.183 | .903 | 1.704 | 11.54 |
| SPATIAL SPAN | 12.48 | 3.57 | .801 | .063 | -.801 |

N = 135

MOCA = Montreal Cognitive Assessment; CFQ = Cognitive Failure Questionnaire; QOL = Quality of life; BSI = Brief Symptom Inventory; CVLT = California Verbal Learning Test; REY = Rey Complex Figure; TMT = Trail Making Test; DIGIT SPAN = Digit Span subset of the WAIS; COWAT = Control Oral Word Association Test; Spatial Span. = Spatial Span subset of the WAIS.

Table 4.2: Pearson's correlation between Psychological measure and Quality of life

| Variables | 1 | 2 | 3 | 4 | 5 | 6 | 7 | 8 | 9 | 10 | 11 |
|-----------|--------|--------|-------|--------|--------|-------|-------|--------|--------|--------|----|
| 1. DEP | | | | | | | | | | | |
| 2. ANX | .64** | | | | | | | | | | |
| 3. HOST | .64** | .69** | | | | | | | | | |
| 4. SOMA | .61** | .66** | .52** | | | | | | | | |
| 5. OBC | .60** | .67** | .62** | .66** | | | | | | | |
| 6. PHOB | .55** | .64** | .48** | .37** | .52** | | | | | | |
| 7. PAR | .46** | .48** | .44** | .26** | .56** | .55** | | | | | |
| 8. PSY | .75** | .72** | .62** | .58** | .70** | .67** | .57** | | | | |
| 9. IPS | .67** | .60** | .62** | .54** | .75** | .58** | .65** | .69** | | | |
| 10. GSI | .81** | .86** | .77** | .75** | .86** | .71** | .68** | .86** | .83** | | |
| 11. QOL | -.34** | -.32** | -.16 | -.42** | -.31** | -.16 | -.15 | -.25** | -.31** | -.36** | |

NB: N=135. 1= Depression, 2= Anxiety, 3= Hostility, 4= Somatization, 5=Obsessive compulsion, 6=Phobic anxiety, 7= Paranoid ideations, 8= Psychoticism, 9=Interpersonal sensitivity, 10=Global severity index, 11=Spitzer's Quality of life. *p < 0.05 level (2-tailed)
** p < 0.01 level (2-tailed).

From table 4.2 above, there was a significant negative correlation between depression and quality of life [$r(135) = -.34, p = .000$ (2-tailed)]. This implies that there was an inverse/indirect relationship between the scores on depression and anxiety. Hence, the higher/lower the level of depression, the lower the quality of life.

Also, a significant negative relationship was observed on anxiety and quality of life [$r(135) = -.32, p = .000$ (2-tailed)], somatization and quality of life [$r(135) = -.42, p = .000$ (2-tailed)], obsessive compulsion and quality of life [$r(135) = -.31, p = .000$ (2-tailed)], psychoticism and quality of life [$r(135) = -.25, p = .000$ (2-tailed)], interpersonal sensitivity and quality of life [$r(135) = -.31, p = .000$ (2-tailed)], the Global severity index of the BSI and quality of life [$r(135) = -.36, p = .000$ (2-tailed)]. This shows an inverse relationship between the domains of

the BSI and the quality of life measure. Therefore, the higher/lower the psychological distress, the lower/higher the quality of life. In conclusion, all things being equal the higher/lower the psychological disorders, the lower/higher one's quality of life.

Table 4.3: Pearson's correlation table of Neuropsychological tests and BSI

| Variables | 1 | 2 | 3 | 4 | 5 | 6 | 7 | 8 | 9 | 10 | 11 | 12 | 13 |
|------------|--------|--------|--------|--------|--------|--------|--------|--------|--------|-------|-------|-------|----|
| CVLT IMM | | | | | | | | | | | | | |
| CVLT S.D | .70** | | | | | | | | | | | | |
| CVLT L.D | .70** | .83** | | | | | | | | | | | |
| REY COPY | .13 | .08 | .06 | | | | | | | | | | |
| REY IMM | .51** | .52** | .55** | .26** | | | | | | | | | |
| REY D.R | .46** | .51** | .55** | .27** | .93** | | | | | | | | |
| TMT | -.42** | -.46** | -.51** | -.08 | -.29** | -.27** | | | | | | | |
| DIGIT S. | .61** | .56** | .56** | .12 | .47** | .45** | -.42** | | | | | | |
| MOCA | .56** | .54** | .52** | .12 | .49** | .48** | -.31** | .54** | | | | | |
| CFQ | -.15 | -.19* | -.14 | -.04 | -.09 | -.11 | -.08 | -.19* | -.09 | | | | |
| COWAT | .56** | .52** | .52** | .11 | .47** | .43** | -.36** | .53** | .49** | -.17 | | | |
| SPATIAL S. | .68** | .55** | .60** | .28** | .57** | .55** | -.46** | .60** | .51** | -.09 | .50** | | |
| BSI (GSI) | -.42** | -.44** | -.45** | -.23** | -.34** | -.34** | .18* | -.35** | -.38** | .56** | -.29* | .41** | |

NB: N=135. CVLT IMM= California Verbal Learning Test Trail 1-4; CVLT S.D= California Verbal Learning Test Short delayed recall; CVLT.L.D = California Verbal Learning Test Long delayed recall; Rey Copy; Rey Immediate recall; Rey Delayed recall; TMT = Trail Making Test; DIGIT S. = Digit Span Test; MOCA = Montreal Cognitive Assessment; CFQ = Cognitive Failure Questionnaire; COWAT = Control Oral Word Association Test; Spatial S. = Spatial Span Test; BSI (GSI) = Brief Symptom Inventory (Global severity index).

*p < 0.05 level (2-tailed) ** p < 0.01 level (2-tailed).

From table 4.3, there was a significant negative correlation between CVLT immediate and GSI [(r (135) = -.42, p= .000 (2-tailed)], CVLT short delayed and GSI [(r (135) = -.44, p= .000 (2-tailed)], CVLT long delayed and GSI [(r (135) = -.45, p= .000 (2-tailed)], Rey copy and GSI [(r (135) = -.23, p= .000 (2-tailed)], Rey immediate and GSI [(r (135) = -.34, p= .000 (2-tailed)], Rey delayed [(r (135) = -.34, p= .000 (2-tailed)], Digit span and GSI [(r (135) = -.35, p= .000

(2-tailed)], MOCA and GSI [$r(135) = -.38, p = .000$ (2-tailed)], COWAT and GSI [$r(135) = -.29, p = .000$ (2-tailed)], Spatial span and GSI [$r(135) = -.41, p = .000$ (2-tailed)]. This implies that there was an inverse/indirect relationship between the scores on these cognitive measures and BSI global severity index. Hence, the higher/lower the performance on these tests, the lower/higher the distress levels.

However, a significant positive relationship was observed between the trail making test and GSI [$r(135) = .18, p < .05$ (2-tailed)]. Similarly, a significant positive correlation was seen between the cognitive failure questionnaire and the GSI [$r(135) = .56, p = .000$ (2-tailed)]. This means that there was a direct relationship between these cognitive measures, thus the test of attention and executive function and the GSI. This means that the higher your scores on executive function and attention, the lower your distress level.

Table 4.4: Frequency and Percentages of Survey Participants SLE'S N= 70 and Healthy Controls (HC) N = 65)

| Variables | Category | Frequency/Percentage | |
|-------------------------------------|--------------|----------------------|----------------|
| | | SLE(70) | HC (65) |
| Gender | Male | 3(4.3) | 4 (6.2) |
| | Female | 67(95.7) | 61(93.8) |
| Age | 18-35 | 63 (90.0) | 63 (96.9) |
| | 36-49 | 7 (10.0) | 2 (3.1) |
| Mean age of groups | | 29.0 yrs (4.05) | 29.1yrs (4.39) |
| Number of years of education (mean) | | 13.67yrs | 14.52yrs |
| Occupation | Employed | 52(74.3) | 40(61.5) |
| | Unemployed | 8(11.4) | 6(9.2) |
| | Student | 9(12.9) | 19(29.2) |
| | Retired | 1(1.4) | 1(.7) |
| Religion | Christianity | 66(94.3) | 57(87.7) |
| | Islam | 4(5.7) | 8(12.3) |

Table 4.4 shows that in terms of gender distribution, there were more females (SLE 95.7%, HC 93.8%) than male participants (SLE 4.3%, HC 6.2%). Majority of the respondents were between 18-35 years (SLE 90%, HC 96.9%) Further it can be observed from the table that majority of the participants have tertiary education (SLE 13 .67 years, HC 14.52 years), and also more than half of the participants are employed (SLE 74.3%, HC 61.5%).

Test of Hypotheses

This sub-section presents the findings from the hypotheses that were tested in the study.

Group Differences on neuropsychological measures

Hypothesis 1: SLE patients will obtain lower scores on neuropsychological measures compared to healthy controls in the following domains:

- i) Attention and executive function
- ii) Memory
- iii) Psychomotor speed/ visuospatial and constructional abilities
- v) Verbal fluency

A One-Way Multivariate Analysis of Variance (MANOVA)

A one-way between-groups multivariate analysis of variance was performed to investigate group differences on neuropsychological measures. Twelve dependent variables were used: CVLT immediate, short delayed, long delayed, Rey copy, immediate and delayed, Digit span, Spatial Span, COWAT, MOCA, Trail, and CFQ. The independent variable was the group with two levels (SLE patients Vrs Healthy controls). The results are summarized on Table 4.5

Table 4.5: Summary of MANOVA results for neuropsychological measures

| Variables | SLE Patients | Healthy Controls | <i>F</i> | <i>P</i> | <i>η</i> ² |
|------------|---------------|------------------|----------|----------|-----------------------|
| | (N = 61) | (N = 62) | | | |
| MOCA | 22.51 ± 3.81 | 27.41(1.91) | 78.56 | .000 | .409 |
| CVLT IMM | 20.70 ± 3.97 | 27.98(3.25) | 128.99 | .000 | .506 |
| CVLT S.D | 5.39 ± 1.33 | 7.27(.853) | 83.64 | .000 | .419 |
| CVLT L.D | 4.77 ± 1.64 | 7.06(.990) | 83.73 | .000 | .423 |
| REY IMM | 18.14 ± 8.31 | 27.90(4.66) | 59.42 | .000 | .349 |
| REY D.R | 18.63 ± 7.82 | 26.51(4.74) | 41.58 | .000 | .272 |
| CFQ | 32.66 ± 15.74 | 28.85(11.46) | 2.87 | .128 | .019 |
| REY COPY | 35.29 ± 1.13 | 35.55(1.08) | 1.05 | .207 | .013 |
| SPATIAL_S | 10.11 ± 2.33 | 15.21(2.56) | 124.93 | .000 | .526 |
| DIGIT SPAN | 14.11 ± 2.73 | 17.85(2.64) | 56.15 | .000 | .336 |
| TMT | 81.43 ± 46.09 | 31.41(23.96) | 51.83 | .000 | .321 |
| COWAT | 11.11 ± 3.87 | 16.42(2.83) | 71.25 | .000 | .387 |

NOTE: MANOVA = multivariate analysis of variance; CVLT IMM= California Verbal Learning Test Trail 1-4; CVLT S.D= California Verbal Learning Test Short delayed recall; CVLT.L.D = California Verbal Learning Test Long delayed recall; Rey Copy; Rey Immediate recall; Rey Delayed recall; TMT = Trail Making Test; DIGIT S. = Digit Span Test; MOCA = Montreal Cognitive Assessment; CFQ = Cognitive Failure Questionnaire; COWAT = Control Oral Word Association Test; Spatial S. = Spatial Span Test. Bonferroni's correction, $p < .004$

Table 4.5 shows mean differences in scores obtained on cognitive measures between SLE patients and healthy controls. Preliminary assumption testing was conducted to check for normality, linearity, multivariate outliers, homogeneity of variance covariance matrices, and multicollinearity, with no serious violations noted. There was a statistically significant difference between SLEs and healthy controls on the combined dependent variables, $F(12, 108) = 23.96, p = .000$; *Wilks' Lambda* = .273; with a high effect size ($\eta^2 = .727$). Bonferroni's correction, $p < .004$. When the results for the dependent variables were considered separately, almost all were statistically significant. The only differences that did not reach statistical significance, using a Bonferroni adjusted alpha level of .004, were on the Rey copy which

assesses visuospatial/constructional abilities, $F(1, 121) = 1.050, p = .207$, partial eta squared = .013, and CFQ which is a self-report measure for memory, $F(1, 121) = 2.87, p = .128$, partial eta squared = .019. An examination of the mean scores for Rey indicated that Healthy Controls performed slightly better than the SLEs on this test assessing constructional abilities, SLEs ($M = 35.29, SD = 1.13$), Healthy controls ($M = 35.55, SD = 1.08$) but this was not statistically significant. Further it can be observed from table 4.2 above that the groups differ in mean scores on the CFQ test which assesses memory, SLE ($M = 32.66, SD = 15.74$), Healthy Control ($M = 28.85, SD = 11.46$) but the difference was not statistically significant.

Summing it all up, the findings indicate that compared to the SLE patients, the Healthy controls performed better on almost all the cognitive measures assessing the various cognitive domains with the exception of constructional abilities and a self-report of memory lapses inventory. This means that the SLE patients are showing signs of cognitive deficits in the areas of Attention, executive function, memory (visual and verbal), and verbal fluency, as compared to the healthy controls.

Hypothesis 2: There will be a statistically significant difference between SLE patients and health controls on psychological functioning and quality of life.

A One-Way Between-Groups Multivariate Analysis of Variance (MANOVA)

A one-way between-groups multivariate analysis of variance was performed to investigate group differences on BSI and Quality of Life. Ten dependent variables were used.

Table 4.6: Summary of MANOVA results for Behavioral measure and Quality of life

| Variables | SLE Patients | Healthy Controls | <i>F</i> | <i>p</i> | <i>η</i> ² |
|-----------|--------------|------------------|----------|----------|-----------------------|
| | (N = 66) | (N = 62) | | | |
| DEP | .661 ± .716 | .106 ± .224 | 34.14 | .000 | .213 |
| ANX | .629 ± .588 | .097 ± .226 | 44.47 | .000 | .261 |
| HOST | .596 ± .585 | .139 ± .179 | 34.81 | .000 | .216 |
| SOMA | .847 ± .741 | .151 ± .303 | 47.61 | .000 | .274 |
| OBC | .993 ± .791 | .435 ± .468 | 23.18 | .000 | .155 |
| PHA | .376 ± .589 | .077 ± .142 | 15.11 | .000 | .107 |
| PI | .956 ± .771 | .730 ± .532 | 3.68 | .057 | .028 |
| PSYC | .497 ± .698 | .084 ± .211 | 19.99 | .000 | .137 |
| IPS | .842 ± .765 | .399 ± .406 | 16.47 | .000 | .116 |
| QOL | 9.17 ± 1.02 | 9.82 ± .587 | 19.65 | .000 | .135 |

NOTE: MANOVA = multivariate analysis of variance; DEP = Depression; ANX = Anxiety; HOST = Hostility; SOMA = Somatization; OBC=Obsessive compulsion; PHA =Phobic anxiety; PI = Paranoid ideations; PSYC = Psychoticism; IPS =Interpersonal sensitivity; QOL= Quality of Life.

Bonferroni's correction $p < .005$

Table 4.6 shows mean differences in scores obtained on the Brief Symptom Inventory (BSI) and Quality of Life of SLE patients and healthy controls. There was a statistically significant difference between SLEs and healthy controls on the combined dependent variables, $F(10, 117) = 7.55, p = .000$; *Wilks' Lambda* =.608; with a moderate effect size ($\eta^2 = .392$). When the results for the dependent variables were considered separately using a Bonferroni adjusted alpha level of .005, statistically significant differences were observed between the SLE patients and healthy controls, on depression, $F(1, 126) = 34.14, p = .000$, partial eta squared = .213. Significant differences were also observed on Anxiety, $F(1, 126) = 44.47, p = .000$, partial eta squared = .261, Hostility, $F(1, 126) = 34.81, p = .000$, partial eta squared = .216, Somatization, $F(1, 126) = 47.61, p = .000$, partial eta squared = .274, Obsessive Compulsion $F(1, 126) = 23.18,$

$p = .000$, *partial eta squared* = .155, *Phobic anxiety*, $F(1,126) = 15.11$, $p = .000$, *partial eta squared* = .107, *Psychoticism*, $F(1,126) = 19.99$, $p = .000$, *partial eta squared* = .137, *Interpersonal sensitivity*, $F(1,126) = 16.47$, $p = .000$, *partial eta squared* = .116 and *Quality of Life* $F(1, 126) = 19.65$, $p = .000$, *partial eta squared* = .135. However no statistical significant difference was observed on *Paranoid Ideation*, $F(1,126) = 3.68$, $p = .057$, *partial eta squared* = .028, between the group. Despite the fact that significant differences were observed between the groups on the measures, the effect sizes were small.

Comparing the mean scores, the findings indicate that the SLE patients experience significantly higher depression ($M = .661$, $SD = .716$) than the Healthy Controls ($M = .106$, $SD = .224$). The SLE patients also reported higher anxiety ($M = .629$, $SD = .588$) than the controls ($M = .097$, $SD = .226$). Further, the controls recorded less hostility ($M = .139$, $SD = .179$) than the SLEs, ($M = .596$, $SD = .585$). Further, the SLE patients recorded more symptoms of somatization ($M = .847$, $SD = .741$) than the healthy controls ($M = .151$, $SD = .303$). The SLE patients again reported higher levels of obsessive compulsion ($M = .993$, $SD = .791$) as compared to the controls ($M = .435$, $SD = .468$). Furthermore, the SLES reported higher phobic anxiety ($M = .376$, $SD = .589$) than the controls ($M = .435$, $SD = .468$). The SLE patients further recorded higher scores on psychoticism ($M = .497$, $SD = .698$) than the controls ($M = .084$, $SD = .211$). Again, the SLE patients had higher scores on *Interpersonal sensitivity* ($M = .842$, $SD = .765$) than the healthy controls ($M = .399$, $SD = .406$). Again on *Quality of Life*, the SLE patients recorded lower mean scores ($M = 9.17$, $SD = 1.02$) than the healthy controls ($M = 9.82$, $SD = .587$). Lastly, the SLE patients reported higher paranoid ideations ($M = .956$, $SD = .771$) than the controls ($M = .730$, $SD = .532$) but this difference was not statistically significant.

Hypothesis 3: There will be a statistically significant positive relationship between cognitive functioning and quality of life of SLE patients.

Table 4.7: Summary of Standard Multiple Regression for hypothesis three

| Model | B | Std. Error | β | t | P |
|--------------|-------|------------|---------|--------|-------|
| 1 (constant) | 7.389 | 1.042 | | 7.091 | .000 |
| CVLT IMM | .001 | .039 | .006 | .038 | .970 |
| CVLT SD | -.060 | .129 | -.091 | -.462 | .646 |
| CVLT DR | .055 | .120 | .093 | .460 | .647 |
| REY IMM | .055 | .043 | .448 | 1.280 | .206 |
| REY DR | -.061 | .047 | -.461 | -1.306 | .197 |
| TRAIL | -.001 | .002 | -.084 | -.604 | .549 |
| DIGIT | .123 | .058 | .335 | 2.101 | .040* |
| MOCA | .022 | .042 | .083 | .520 | .605 |
| CFQ | -.012 | .008 | -.200 | -1.527 | .133 |
| COWAT | -.015 | .042 | -.056 | -.352 | .726 |
| SPATIAL S. | .040 | .060 | .091 | .667 | .508 |

Note: $R^2 = .23$, ($p < .05$), * $p < .05$

Hypothesis 3: stated that there will be a statistically significant positive relationship between cognitive functioning and quality of life of SLE patients. A standard multiple regression was carried out to test this hypothesis. Preliminary analyses were conducted to ensure no violation of the assumptions of normality, linearity, multicollinearity and homoscedasticity. The results as shown in table 4.7 above indicated that, the model explained 23% of the variance in Quality of Life and that the overall cognitive measures are not a significant predictor of Quality of Life, $F(11, 53) = 1.43$, $P = .186$. Of these variables, only Digit span, a test which assesses attention makes a statistical significant contribution (beta = .123, standard error = .058, $p = .040$). Therefore the hypothesis was not supported.

Hypothesis 4: Differences in quality of life among newly diagnosed SLE patients and those who have been living with the condition for more than 2 years was also assessed. An independent T- test was conducted to examine this difference. The results of the T-test analysis are summarized on Table 4.8

Table 4.8: Summary of t-test results on QOL between the newly diagnosed SLE patients and those who have lived with the condition for more than 2 years

| Tests | Groups | N | Mean | SD | df | t | p |
|-------|-------------|----|------|------|----|------|------|
| QOL | 0-24 Months | 44 | 9.25 | .943 | 68 | .848 | .400 |
| | >24 Months | 26 | 9.04 | 1.11 | | | |

Table 4.8 shows mean difference in SLE patients who have lived with the condition for less than two years and those who have lived with the condition for over two years. It can be concluded that there was no statistically significant difference in quality of life of the two groups, 0-24 months (M= 9.25, SD= .943) and > 24 months (M= 9.04, SD= 1.11; $t(68) = .848$, $p = .400$ Mean difference observed is (.212, 95% CI: -.286 to .710) (eta squared= 0.02), therefore the hypothesis was not supported.

Summary of Findings from Study 1

This study tested five main hypotheses to assess the neuropsychological functioning of people living with Systemic Lupus Erythematosus (SLE) in Ghana. The summary of findings is presented below:

- SLE patients differ significantly on cognitive tests assessing attention, executive function, memory, visuo-constructional abilities and verbal fluency than healthy participants.

- The SLE patients experienced higher level of psychological distress than the Health controls but on paranoid ideation, the difference between the groups was not significant.
- There was no statistically significant overall relationship between cognitive functioning and quality of life of SLE patients. However, there was a positive correlation between the test of attention and quality of life.
- Age, years of education and disease duration did not moderate the relationship between cognitive functioning and quality of life.
- There was no statistically significant difference between SLE patients who have lived with the condition for over two years and those who have been diagnosed two years and below on quality of life.

Study 2: Qualitative Results

The qualitative findings are presented based on the central research questions that were raised. First of all, the qualitative analysis answered the question of the lived experiences of SLE patients. Secondly, ‘what are the coping strategies employed by SLE patients? These two fundamental research questions guide the presentations of the qualitative findings.

Research Question1: What are the lived psychological experiences of SLE patients?

The presentations of findings on this research question is divided into two; a) the challenges that SLE patients encounter, B) the supports that SLE patients receive. The representations of challenges encountered by SLE patients are presented first before the support they receive.

1a) What are the challenges that SLE patients encounter?

People go through diverse challenges when they are diagnosed with chronic ailments that they have to live with for the rest of their lives. This research question examined the views and perceptions of the participants concerning the difficulties they encounter. The presentations of

findings on this research question is put under one superordinate theme; **challenges of SLE patients**. **Seven sub themes** emerged concerning the challenges people living with SLE encounter; physical challenges, emotional, financial, issues with medication, challenges explaining the condition, fertility challenges and forgetfulness. Each of these themes are described and interpreted below.

Physical Challenges

The respondents in this study reported that they face several challenges as a result of their condition. According to them, they were very active and going about their normal businesses before the condition settled in. This was reported by all the 11 participants. One of the quotes from a respondent is as follows;

“Ohh me my life was normal oo. I used to work normal, no pain, no difficulties, I was able to go about my normal day to day activities with no difficulty. I could do my house chores by myself, scrub my bathroom, my hall, in fact I could do everything” (Female, respondent 5).

However after diagnosis, participants reported having difficulties with normal daily activities.

“The other challenges has got to do with myself. The things I can do basically but am not able to do. For a long time now I am not able to wash because of the pains in my fingers. Now my hands are still stiff, i can't grind something. I can't grind pepper in the earthenware bowl, I can't do this petit, petit stuff so sometimes emmmm (paused) it's quite emm hurtful” (Female, respondent 3).

“Hmm. My only challenge now is the weakness I feel. Normally I like to do things on my own but when am weak I can't. I have to rely on others to help me. This weakness scares me a lot. I feel like a time will come that I can't do anything by myself. And also I forget things” (Female, respondent 5).

‘That’s what I told you that I am not active like I used to. That is my major challenge. Formally I could walk a long distance but this days if am going anywhere I have to take dropping (taxi)’
(Female, respondent 10).

Emotional challenges

The second theme that emerged is the emotional challenges that SLE patients experience. This theme is divided into two categories; **negative and positive emotions**. Majority of the respondents’ expressed negative emotions about their condition. The common word that most participant used to express their feelings is ‘sad’. They reported that their condition makes them have feelings of sadness.

The **negative emotions** expressed by these participants includes depressive symptoms, fear, suicidal thoughts, dislike and worry. Below are some quotes:

‘It doesn’t make me happy. Hmm.... It’s an issue oo (eye asem oo). The last time I came for review, emm...they gave us teaching about the sickness,....infact it made me sad but what will one do?(wo be ye no den) when day breaks and you wake up and you are alive then you thank your God. Yes oo, life is important’ (Female, respondent 1).

‘I get depressed by coming to clinic because I see people who are in worse conditions and then you ask your self is this the end’ (Female, respondent 6).

Further, participants indicated that they have fear about the condition because they are uncertain about the future: *‘Emmm... the challenges they are quite a few. You know the fear aspect, you know this condition even though you are taking medication anything can happen at any time. You have fear that what if one day I should fall ill, will I go back to how I was, am i going to suffer the same fate like I did before, the money you are going to spend and other things. There is also the fear of like getting married, having children, will I be able to bear*

children, will I be able to take care of them, my family, that one is also there'' (Female, respondent 11).

One respondent reported that she feel bad about the condition and that she sometimes has suicidal thoughts because she is not like she used to be before the condition started. She however reported that her condition is far better than some other people she saw at the clinic so she is still hanging on: *''Hmm... I feel bad and sad. Sometimes I feel like taking my own life, ooh its true oo when you see how you were first and now you are not like that its very painful. But when I was admitted at korle bu and I was put on the third floor at medical, I saw that I am not the only one and that some even have worse conditions than mine so am hanging on like that, let's see what God will do'' (Female, respondent 2*

Despite the negative emotions expressed by majority of the participants, they were hopeful that a cure would be found for the condition and that God will heal them. One participant was actually positive about his diagnosis, he did not express any negative emotions but hopefulness which is a **positive emotion**. Below are some quotes:

''Hmm what will I do? The sickness has come already and there is nothing I can do. Hmmm I don't feel anything. I have hope. I believe that God will heal me. So far as there is life, there is hope'' (Female, respondent 5).

''Ooohh really for me I think it's one of those things. We only give God praise that we are still strong and we are going about our normal activities. Emm for me as a believer, as a Christian I see that emm it's just one of those things and I know it's going to move away one day and so sometimes i don't really bother myself worrying about it'' (Male, respondent 9).

Financial challenges

Some of the respondent expressed worry about how they are finding it difficult getting their medications because of the cost. They indicated that the drugs are expensive and that they spend more than a half of their income on medication. Other reported that they are not able to work like before so they cannot take on extra jobs so as to earn more income. Four of the respondents expressed this view.

“Eeem the other one is the toll on my money that’s my major challenge. Like I said, at first I had the other source of income and that was enough for me so I could just save my main salary and use it for other things but now it’s only my salary and the drugs you come in to buy is almost taking aa about a third, almost a half of your salary, yeah and you can’t use the other side for anything because there are other budgetary allocations” (Male, respondent 9).

“just that the medication is the problem, it is expensive. Now I can’t work, I can’t stand ” (Female, respondent 2).

“Emm am not working for a very long time so I do have financial challenges. Sometimes I have to fall on some friends and relatives” (Female, respondent 10).

Issues with medication

Some of the respondent also expressed issues about the medications that they are on. They reported that the side effects of the medications are really affecting them. They further have issues with the fact that they have to always be on medications.

“My life, really my life is destroyed (basa). The medicine has made me gained weight and also it has affected my hips. I was told the medication has cause a deformity in my hip bone so I have to undergo surgery in my hips. I have been on the medication for close to three years now” (Female, respondent 2).

“My major challenge as I told you earlier is the fact that I have to be on the medication. That is the only challenge I have” (Female, respondent 7).

“And also the medication, (giggling...)I buy it, I take it but sometimes when I take it, it doesn't go, I vomit all out” (Female, respondent 1).

Challenges explaining the condition

One respondent explained that she has difficulties explaining to people that she is not well because physically she seems to be fine. She reported that having to convince people that she is not well is a major challenge she is facing. Stated below is her quote:

“The only challenge I think i have is emm making people understand what really is wrong with me. Myself I find it difficult explaining it nhmm so it's very difficult making people understand. Like I was coming here this morning, I had to ask permission, my boss, they may not understand because they see me going about, doing everything and yet I always ask permission to come at least every 3 or 6 months. That has been my challenge, convincing people that yes really something is happening inward” (Female, respondent 4).

Fertility challenges

SLE is a condition that mostly affect females, however, some few males have the condition. The only male participant in this study expressed issues with fertility. He reported that the medication, according to his doctor has affected his sperm count. He was however told that this will improve with time but it's been 7 years and there is still no change.

“Aah I think the other one it's not soo great but it is. That has to do with my wife, it is still now a challenge for us conceiving, yes that one major challenge with all this health, health things that's come about. We didn't have any children before the condition started. When we got married, we were taking a course so we talked about it and decided to hold on, let's finish

before children come in and then pumm early 2013 this whole thing started and it's been drugs, drugs, drugs and one doctor at Koforidua hospital who my wife when i was getting a little bit well, my wife and my sister they sat me down and told me that this doctor said the medication he is giving you this and this is the possible side effect. So I was like aah and you guys told him what? They said that is the medication that will help you but he said if that happens, things will return back to normal after sometime. Immediately I went for some checks, this semen analysis and then truly it proved nil and they said after sometime and we have been on it and in fact my rheumatologist and I have talked so much about it. It's another little headache for me. So we are only prayerful, we are hoping and we are expecting that God will smile on us one of this days because it's been 7 years'' (Male, respondent 9).

Forgetfulness

One participant reported forgetfulness as a challenge to her. According to her, she used to be very smart and could remember everything but after diagnosis and being on treatment for some time now, she has noticed that she is forgetful.

And also I forget things. I am very forgetful lately, something I leave important things undone for day and also forget appointments. I didn't use to be like this.. (Female, respondent 5).

1b) What are the supports that SLE patients receive?

This research question sought to explore some of the support (social support systems) that SLE patients have benefited from. The findings from this question are categorized under one main theme; **social supports SLE patients receive**. Findings from this study revealed that the patients receive massive support from their loved ones and support group. However, three respondents stated that they do not get any form of social support. Almost all the participants reported receiving support from their families and friends. The supports the participants received has been categorized under **three sub themes**: emotional support, instrumental and

informational support. Some participants reported getting all the three forms of social support, others reported two and some reported just one form of social support. These themes are discussed below:

Emotional support

Participants reported that they get emotional support from their families and friends. They reported that they get inspiration and words of motivation from their friend and family.

“Yeah from family, they support me, my immediate family, they support with chores and also encouragement, my extended family they support, they call to check up on me. For financial, am working so where am working they take care of all the financial situations, am not really bothered about the finances. But before I started working, my siblings were supporting. Now my job pays for all my medical....Yeah so am not really bothered about it now” (Female, respondent 3).

“Oo emm the motivation and all that, sometimes financially, my family supports” (Female, respondent 4).

“Emmm... for support from friends, it's not monetary per say but emm, they are just there for me. They know I have this condition but i don't want to be pitied so for the pity no body pities me but they just make me know that in case I need anything they are there. Family too are there, it's not everybody that knows the details about my diagnosis, all they know is that I am not well aha but for those who really know sometimes they call and ask are you still on the medications, try and make sure that everything is okay with you but they don't treat me as different as they used to” (Female, respondent 11).

Instrumental support

Some participant stated that they receive instrumental or tangible support from family and friends. They reported that their families and friends are always there for them when they are in need. They support financially and assist with chores.

“Yeah basically like I told you my family has been of great support, great, great, great assistance, my wife of course is always with me, she actually is the pillar you know. And my other siblings actually wouldn't let me go. You know my blood group, am a 'B' and you know the 'B's actually have a lot of challenges when they want blood but my siblings are always there and other cousins. They will travel from far and near, come, donate and some friends as well. So as for those kind of assistance my family is always there. When it come to the money, money thing as well, of course they will quickly do some contributions and then.....my daddy always, always yeah, so my family is a great pillar behind me, they have never let me down”
(Male, respondent 9).

“My mother also takes care of my child. She sometimes helps me dry my clothing when I finish washing and I can't stand to hang them on the drying line” (Female, respondent 2).

“Yeah I get support from my immediate family, the encouragement, helping do the things I can no longer do on my own” (Female, respondent 6).

Informational Support

One participant reported that she is a member of a support group for people living with autoimmune disease. According to her, they receive periodically education on the condition and how to manage it. Below is her quote:

“I work with the rheumatoid Initiative (Tri) so Tri has been there for me since day one that I joined. I joined them in 2015 and they are, for now my whole life is Tri, my parents are in

Tri, all my friends are in Tri. They have taught me a lot about how to manage the condition. When I was diagnosed I thought I was the only one even though I have read some few articles on the internet which was a bit scary but when I came in, I went for some of their meetings I realised that like you could live life. There are adults in there who have giving birth and are doing stuff , even younger ones who are doing big, big things so I just told myself that the condition wasn't all, there are things that I can do with it. I can live a good quality life so for Tri, Tri has helped me a lot. And there are sometimes too it becomes challenging affording medication and Tri has come through for me'' (Female, respondent 11).

No social support

Some of the participant reported not getting any form of support from family and friends.

“I don't get any support from anywhere. It's me. No no no “ (Female, respondent 1).

“Ok I don't get financial support from anyone not even from family. I don't get any support at all” (Female, respondent 8).

“No support at all. As for my family they feel am alright but within me I know am not fine” (Female, respondent 10).

Research question 2: What are the coping mechanism employed by SLE patients?

This research question required exploring some of the coping strategies that SLE patients adopt. The main theme is **coping strategies employed by SLE patients**. Results from this study revealed that coping mechanisms included: spiritual coping, inspiration from significant others, personal survival efforts, believe in the treatment and support group. Majority of the participant used more than one coping strategy but almost all reported using spiritual coping. Some also dwelt more on their individual strength.

Spiritual coping

This was the common coping strategy participants used in coping with their diagnosis. Most resorted to believe or faith in God, and also prayer. The major elements in the religious coping are the use of prayer and reading the word of God as means of diverting their worrying thoughts:

Some participants reported: *“In fact God is the factor. God will let me suffer a little and later he will take me out. God will again glorify himself because he will not allow these things to just come over you and then put you down to emm so I have also psyched my wife up the same way”* (Male, respondent 9).

“Oo I have faith in God so I pray every day. I know he will come through for me” (Female, respondent 10).

“I also rely very much on the word of God, it gives me a lot of motivation to move on” (Female, respondent 4).

“Trust in God to is another thing, faith in God because I feel like its God who helped with my diagnosis and once that you have seen what is happening, you can treat it. And looking at what I have been through and am still alive and giving hope to others ahha it’s like am ok” (Female, respondent 11).

“Hmm I always pray to God to heal me and I know a time will come the doctors will tell me that I am healed” (Female, respondent 5)

Inspiration from significant others

Other participants also draw some form of motivation from family and friends. According to them, their children motivate them to keep living.

“Sometimes I get tired of fighting and I feel like giving up but my daughter motivates me to keep living. If not for my daughter, sister, I would have taken some medicine and ended it long ago. Its true but when I see her....., sometimes when am not even happy and she comes to sit with me, she says things that will make you laugh” (Female, respondent 2).

“hmmm I believe I will be fine with time and also I have children so I want to be healthy and take care of them.so far as I have life, there is hope” (Female, respondent 8).

“My daughter motivates me, she is married now and has a child, she is expecting the second one, I want to live and see all my grandchildren. So far as I have been able to live with this condition for all this time I know all will be fine” (Female, respondent 10).

This participant reported that she gets great support from her friends and family and that’s what motivates her *“And also I have a good solid family support, I have great friends, I have friends who will do crazy stuff for me. Just like yesterday I wanted to go get my labs and a colleague, she is my supervisor she drove me all the way to MDS to go and collect my labs and I went home. It’s not everybody who will do that for you. There are so many people who do so many stuff for me I just wonder that it’s God so you know it motivates me” (Female, respondent 3).*

Personal survival efforts

Some respondents also dwelt more on their strength. They reported being positive about the condition and trying not to think about it. They used avoidance and also they engaged in distractive activities such as watching television series or listening to inspirational songs to take their minds off their condition. One participant actually reported that she enjoys watching Korean series and that it makes her happy.

“Now am more positive, I don’t even worry about stuff I can’t do anymore, you know, because the more you think about it the more you get depressed. I try to do so many things that makes

me happy. And I cut out people who try to stress me. I love Korean series so I watch it to make myself happy'' (Female, respondent 3).

''To be honest I don't think about it, I don't spend time thinking about lupus that what is going to happened, I don't do that. I try to do things that make me happy. I easily get stressed from work so every time when am driving between work and home, it's like 2 hour drive because of traffic, I have like song I listen to, I will make sure that period I am not worried about anything am just you know.... Fine'' (Female, respondent 6).

''Eeeiiii life motivates me oo. As for me I want to live so I do everything possible to live. I take my drugs, make myself happy and I also stay away from foods that my doctor has advised against'' (Female, respondent 5).

Believe in the treatment

Two of the respondents stated that they have seen improvement in their health since they started treatment so they believe that they can only get better. This motivates them to keep living.

''I think that I have been on the drugs and my health has gotten better, it's like 4 years ago, like how I was even looking and now, (paused) I can only get better'' (Female, respondent 6).

''And you know since I started coming here and I have been taking my medicine to I saw a big difference that I am ok, no more sickness like before'' (Female, respondent 7).

Support group

Two of the participants reported that they get the motivation to keep fighting from their support group. According to them, they hear and see people who are living with the same condition moving on in life and achieving great things so this motivates them to keep on living. They surrounded themselves with such supportive network to help them manage the situation. This is emphasised in their quotes:

“I also see and hear stories of people who are living with the condition and are doing well so that gives me hope to know that all is not lost. Am a member of Tri” (Female, respondent 4).

“Emm you know in the support group we have people with different conditions and there are some with some severe conditions that I ask myself, so you have this and you are worried what if you had that/ and aside that too, there are people in the group, there is a lady in particular she is doing dialysis, she comes to do it almost every time, she comes to the, she is working at the bank, she has done more of her schooling staff and she still wants to go and read law so am like look at this person, she should have given up on herself but she is fighting so what excuse do I have? I don't have any excuse. Ahha so some of this things are my motivation and also giving people hope is another motivation” (Female, respondent 11).

SUMMARY OF KEY QUALITATIVE FINDINGS (N=11)

Table 4.9: Summary of Key Qualitative Findings (Challenges that SLE Patients encounter)

| Superordinate Theme | Sub theme | Findings |
|----------------------------|-------------------------------------|---|
| Challenges of SLE | Physical challenges | •Difficulties with work and normal daily activities |
| | Emotional challenges | Negative emotions: Sadness Depressive feelings, Fear, Suicidal thoughts, Dislike, and Worry. Positive emotion Hopefulness. |
| | Financial challenges | •Challenges getting medication because of the cost |
| | Issues with medication | •Side effects of the medication •Issues with the fact that they always have to be on medication |
| | Challenges explaining the condition | •Difficulties getting people to understand the condition. |
| | Fertility issues | •Reduction in sperm count |
| | Forgetfulness | •Forgetting to do important things |

Table 4.10: Social Support that SLE patients receive

| Superordinate theme | Sub themes | Findings |
|--------------------------------|-------------------|--|
| Social Support received | Emotional | •Inspiration and words of motivation from families and friends |
| | Instrumental | •Tangible support in the form of helping with chores and financial support. |
| | Informational | •Information about the condition and how to live with it from a support group. |

Table 4.11: Coping Mechanisms by SLE Patients

| Superordinate theme | Sub theme | Findings |
|----------------------------|-------------------------------------|--|
| Coping Strategies | Spiritual coping | •Using prayer and reading the word of God as a form of coping. |
| | Inspiration from significant others | •Motivation and support from family and friends |
| | Personal survival efforts | Using avoidance and engaging in distractive activities as a form of coping |
| | Believe in the treatment | •Having faith in the efficacy of the medication |
| | Support group | •Drawing inspiration from members of a support group |

CHAPTER FIVE

DISCUSSION

This chapter discusses the findings of the current study. For the purposes of clarity and simplicity, findings from the quantitative and the qualitative studies are discussed separately with the quantitative findings being discussed first followed by the qualitative findings.

The findings from study 1 have showed mostly that healthy controls and SLE patients differ with regards to their neuropsychological functioning. First of all, the SLE patients experienced more cognitive challenges compared to healthy controls. These challenges manifested in the areas of memory, attention, executive function, verbal fluency and constructional abilities. This findings are consistent with Leslie and Crowe's (2018) meta-analysis of studies on cognitive functioning which also found that relative to healthy controls, SLE was related with statistically significant deficits in tests of visual reasoning, verbal fluency, immediate visual memory and visual attention. Furthermore this outcomes supported cognitive instabilities in SLE. There is growing evidence supporting the fact that cognitive changes are apparent in SLE folks. Mani, et al. (2015) assessed memory and learning functions among SLE patients and healthy controls. Findings showed SLE patients have deficits in memory components (visual and verbal memory) and memory processes than the healthy control. This findings are also consistent with findings of the current study. Patients with SLE showed poor memory function on the various memory tests they were assessed on. For instance on the Montreal Cognitive Assessment (MOCA) test which is a cognitive screening tool assessing various domains including visuospatial/ Executive, memory, attention, verbal fluency and abstraction; the SLE patients showed deficits in the various domains compared to controls. This current finding is consistent with the study of Butt et al. (2017), which also reported cognitive deficits in SLE patients using the MOCA. The hypothesis which stated that SLE patients will obtain low scores on

neuropsychological measures assessing the domain of attention and executive function, memory, visuospatial abilities and verbal fluency was therefore supported.

Secondly, with regards to behavioural functioning, it was observed that the SLE patients experienced more distress compared to the controls. As noted from the results of this study, the Brief Symptom Inventory [BSI] was able to distinguish the SLE patients and healthy controls on the various domains: somatisation, depression, anxiety, obsession-compulsion, interpersonal sensitivity, hostility, phobic anxiety, paranoid ideation, psychoticism and global severity index. In all these areas with the exception of paranoid ideation, the SLE patients obtained statistically significant higher scores than the healthy control group. These findings means that SLE patients experience higher levels of psychological distress compared to health controls. However, on paranoid ideation, the difference between the patients and the controls was not statistically significant. Hypothesis 2 was therefore supported. This finding may be due to the fact that the patients may be going through some challenges that is causing them more distress. Findings are consistent with previous studies (Barraclough, et al., 2019; Nicassio, et al., 2011; Bachen, et al., 2009; Kozora, et al., 2006) which reported that compared with healthy controls, SLE patients scored higher on measures of depression, fatigue and anxiety. In addition to depression and anxiety which most studies identified to be the most common psychological disorders prevalent in SLE, the current study also found somatisation, obsession-compulsion, interpersonal sensitivity, hostility, phobic anxiety, and psychoticism to be prevalent in the Ghanaian population of SLE patients.

Thirdly, in terms of quality of life, the current study revealed that the healthy controls reported better quality of life compared to the SLE patients. There is an indication that the neuropsychological challenges experienced by these relatively young population of SLE patients has negatively affected their quality of life. Moreover, Stuss and Alexander (2000)

maintained the fact that the frontal lobe is connected to the human limbic system, therefore, challenges in other areas like executive functions and memory are more likely to have caused psychological distress and also affected the quality of life of these people. The findings of this study are consistent with the Luria theory in that, the theory proposed interconnection between all the functional units in the brain stating that a deficit in one, may affect functioning in the other. It can be observed from the findings that the SLE patients have neuropsychological challenges which is affecting their quality of life negatively. The health related quality of life theory further proposes that when an individual rates one domain of his life, for instance his physical domain as being significant to his overall quality of life, he or she would report poor quality of life when that aspect is threatened by an ailment or a disease. The SLE patients reported poor quality of life compared to the health controls due to the health challenges they face. They outlined the difficulties they encounter in the qualitative study. These findings are also consistent with the Health Related Quality of Life theory. Further, the findings are consistent with some of the studies reviewed (Wu et al., 2016; McElhone et al., 2006) which reported a reduced quality of life in SLE patients.

Further, it was found that attention positively predicted quality of life among the SLE patients; meaning the higher an individual's attention span the better his or her quality of life. This study did not explicitly reveal memory as a predictor of quality of life but it can be deduced that attention plays a role in memory. However, according to Atkinson and Shiffrin's Information processing Model (1968), attention is important in order to commit information to memory so poor attention span can lead to poor memory. Memory is important in every aspect of life. Inability to remember important events, names of loved ones and responsibilities at work can be devastating resulting in poor quality of life. This finding is inconsistent with a study by

Williams et al. (2017) which reported an association between cognitive impairment in delayed recall and overall quality of life among cancer patients prior to treatment.

Finally, disease duration was not found to significantly affect quality of life; the quality of life of newly diagnosed and those who have lived with the condition for more than two years was practically similar with just a little difference which was not statistically significant. It could be expected that SLE patients who are newly diagnosed will have more distress than those who have been living with the condition for more than two years and therefore may report poor quality of life because the unspecific symptoms of the condition may cause frustration and concern in these patients. Diagnosis and likelihood to start a treatment which one has to be on for life might also come as another form of psychological distress. Patients might respond to the diagnosis with panic and anxiety, not knowing what to expect. Based on these, it was hypothesised that those who have lived with the condition for more than two years will have better quality of life compared to newly diagnosed. However, the current study did not find any statistically significant difference between the two groups. The hypothesis was therefore disproven. This could be because the participants have not seen any significant improvement in their health even years after diagnosis. This finding is inconsistent with that of Olesinska (2018) who reported that SLE patients learn to accept the condition with time, search for information and also learn to recognise triggers of a flare. Further, Urowitz et al., (2014) assessed quality of life among SLE patients and found that quality of life is unchanging over time in late- stage lupus but improves in early diagnosis stages up to two years.

Findings from study 2 have shown that SLE patients face various challenges in their lives as a result of the condition. Study 1 revealed that SLE patients have poor quality of life compared to healthy controls even though they are on treatment. This part of the study sought to then explore factors that may be accounting for this by exploring the challenges faced by SLE

patients. Participants reported noticing significant changes in their lives after diagnosis which according to them is serving as some form of distress to them and having a negative impact on their quality of life. They reported physical challenges, emotional challenges, financial challenges, issues with medication, challenges explaining the condition, fertility challenges and forgetfulness. The dominant word participants used to describe their lives before the condition started was 'Normal'. According to them they had normal lives before the symptoms actually started. Terms like "work well", "do everything", "do anything", and "go about normal daily activities" were used by the participants to mean normal lives. Their explanation meant that having a normal life is going about your daily duties without difficulties, problems or any health challenges. However, participants reported changes in their lives after diagnosis. They explained that they have difficulties going about their daily activities due to fatigue and joint pains which are some overt symptoms of the disease. Some participants reported emotional challenges; they reported having negative emotions due to the condition but some were also hopeful despite their challenges. Financial challenges, side effects of medications, difficulty explaining the condition to others, forgetfulness and fertility issues were also reported as challenges. Findings of this study are consistent with that of Barros et al. (2012) which stated that patients have reported changes in their lives as a result of treatment side effects, the lack of knowledge about the disease, difficulties in working and changes in their relationship with others. This study, focused on how (SLE) has changed the lives of affected females. It did not really focus on exploring the challenges experienced by SLE patients as a result of their condition as has been done in the current study. Further, findings from this study are consistent with that of McElhone, et al. (2010) which explored the lived experiences of (SLE) patients and reported that SLE patients experience emotional difficulties; fatigue; pain; career prospects and loss of income; side effects of treatment; need help from others with daily activities and have issues with conception.

Additionally, findings from study 2 showed that SLE patients receive some form of social support from significant others and also from support groups. Social support refers to the countless forms of relationships that individuals have with others that helps them to cope with a particular challenge. It is usually classified into instrumental, emotional, and informational support (Seeman, 2008). Findings from the current study showed that patients receive emotional support in the form of encouragement or words of hope from significant others, instrumental support in the form of help with their chores and informational support, that is the help that people may offer through the provision of information about the condition. This means that the patients may be able to adjust well to the changes in their lives, experience less distress and also have a better quality of life as compared to people with no support system. LaRocca et al. (2015) reported that persons who are satisfied with the kind of support they receive are likely to have improvement in their quality of life.

Lastly, findings from study 2 revealed the various forms of coping strategies used by SLE patients; these included spiritual coping, inspiration from significant others, personal survival efforts, believe in the treatment and support group. Participants use the above strategies as a way of dealing with or managing their challenges. In other words, the patients derive some form of motivation to keep living by using these coping skills. Lazarus and Folkman (1984) suggested two types of coping reactions; emotion focused and problem focused. Emotion-focused coping includes adopting strategies to lessen negative feelings that comes about as a result of stress. Emotion focused coping techniques include: praying, emotional disclosure, distraction, suppression and drug therapy.

Problem focus coping on the other hand focuses on dealing with the root cause of a challenging situation that is causing stress, eventually reducing the stress. Problem focused strategies include: time-management, problem-solving and obtaining instrumental social support.

It can be inferred from the current study that SLE patients use more of emotional coping strategies to cope with their condition. According to Carver, (2011) emotional focused coping is a strategy to lessen distress by reducing or averting the emotional component of a stressor. Further, Folkman and Lazarus, (1988) reported that emotional focus coping is appropriate for stressors that seem overwhelming like a chronic ailment diagnosis (Folkman & Lazarus, 1988).

Summing it all up, findings from study 2 is consistent with findings from a south African study by Phuti, et al. (2019) which reported that SLE patients expressed physical challenges such as fatigue, which makes them dependent on other. The patients further reported low emotional states, financial challenges and difficulties with fertility and childbearing. Again, the participants reported using spiritual coping strategies.

Integrating the findings of the two studies, study 1 revealed that the SLE patients have cognitive deficits in all the various domains assessed; and this was confirmed in study 2, as participants reported forgetful as a challenge. Further, in study 1, the SLE patients obtained higher scores on the BSI compared to controls meaning they experience high levels of psychological distress; and this is consistent in study 2 as the participants reported emotional challenges. They explained the challenges they experience as a result of the condition and how that affects their emotions. They reported depressive symptoms, sadness, fear and worry. Finally, the SLE patients had poor quality of life compared to controls in study 1. Participants in study 2 reported that the condition has had a negative impact on their lives including physical, emotional and financial and that their quality of life has been significantly affected.

Findings from both studies revealed the neuropsychological challenges experienced by SLE patients and its impact on their quality of life.

The diverging issues identified in the two studies are; majority of the participants reported cognitive challenges on the Cognitive Failure Questionnaire in study 1 but this was not consistent in study 2. Only one person reported forgetfulness as a challenge in study 2. This might be due to the fact that majority of the participants interviewed in study 2 are engaged in works/ jobs that does not involve them using more of their cognitive abilities and this may be the reason why they do not consider their cognitive deficits as a challenge. Furthermore, based on the findings from the study, the researcher decided to explore coping in study 2 to find out how the participant are holding in despite their challenges. This was not measured in study 1.

Observed Conceptual Model

Figure 5.1 below shows the revised conceptual framework presenting the outcome of the study. The results showed that SLE significantly affected neuropsychological functioning and quality of life of participants in the study. Additionally, attention predicted quality. Finally, findings from the qualitative study revealed that the challenges SLE patients encounter significantly impact their quality of life.

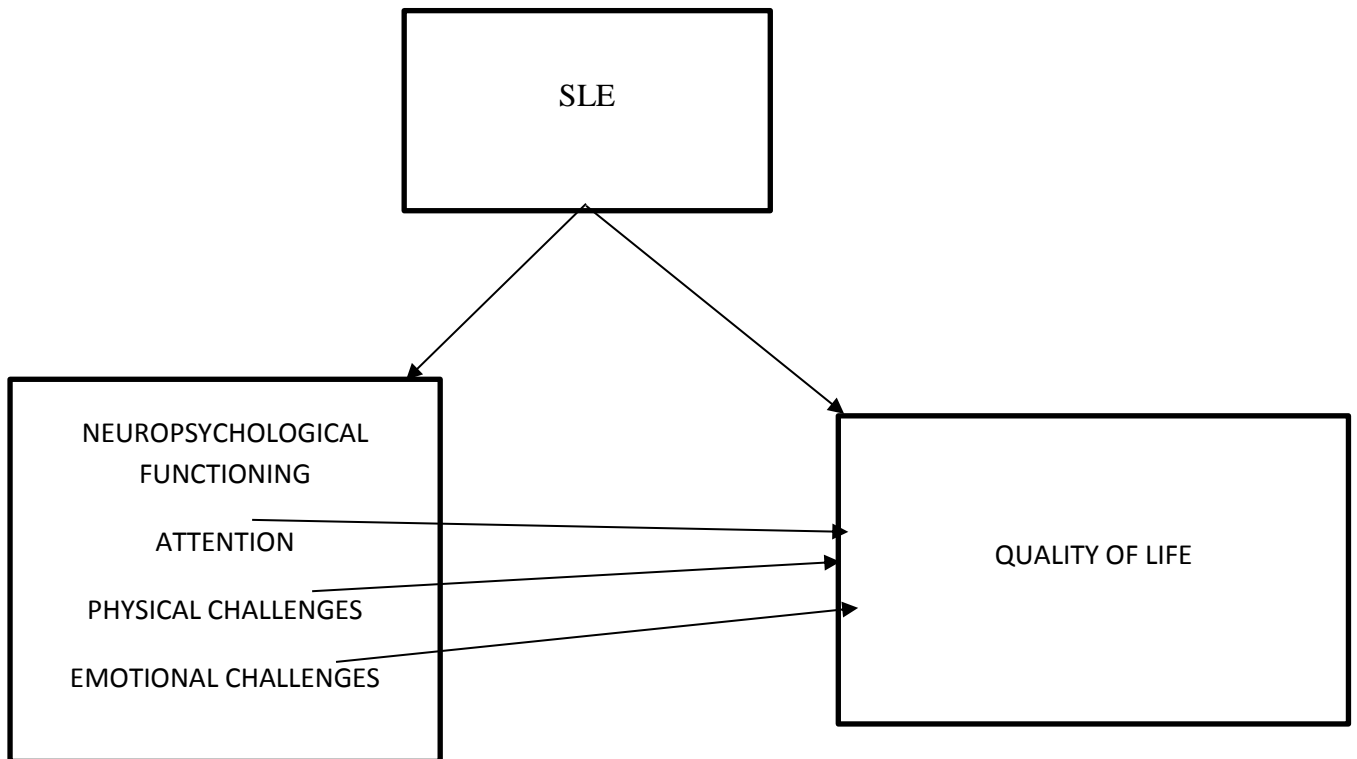
Figure 5.1: Observed Model

Implications of Findings for Clinical Practice

The main findings from this study confirm that SLE may affect the neuropsychological functioning and quality of life of patients. Crucial to these findings is the challenges that the patients reported as being an impediment to their quality of life. Due to these challenges, the clinical management skills of professionals have to be improved to include skills required to screen subtle cognitive deficits in SLE patients or better still, an eclectic health care approach where other professionals like psychologists are involved in the care and management of these patients.

In effect, neuropsychological screening tools and other quality of life measures must be added to the routine care of individuals living with SLE or any chronic disease. This integration between medical and neuropsychological care will demand for a comprehensive training and

advancement of technical knowledge among clinicians. Additionally, the outcomes of this study offers suggestions to the Ministry of Health and Ghana health Service to adopt and effectively implement the biopsychosocial approach to the management of chronic illness by employing qualified Clinical Psychologists into the various health care institutions to assist in the psychological care and management of systemic lupus erythematosus and also other chronic illness.

In view of this, professional organizations and training institutions offering health related courses can include and train their students and researchers on the psychological problem that chronic illness imparts on the overall health of people. This to a large extent will help in referring patients to appropriate places where they can get help.

Limitations of the Study

There are some limitations that should guide interpretations and applications of the findings in the study. First of all, the current study did not include brain scans in the data collection process to identify any brain or central nervous system abnormalities in the participants which could have confirmed the neuropsychological challenges reported in this study.

Another important limitation worth noting is that participants were tested only once; there was no baseline data to compare the performance of participants. Future studies should consider a pretest- posttest design where participants are test on two different occasions and the results compared.

The study failed to compare patients who receive some form of social support and those who do not receive any support on the behavioural measures. Future studies should consider this to be able to establish whether differences exist between the two groups on psychological distress and quality of life.

Finally, the sample size of the SLE patients (70) although may be justified in the scope of clinical studies reduces the generalisation of findings.

Notwithstanding all these shortcomings, the current study fills some research gaps in studies on SLE in sub-Saharan Africa. It has examined and explored the neuropsychological functioning of SLE patients using an explanatory sequential mixed method approach. To the best of the researcher's knowledge, no study has employed this method in sub-Saharan Africa to actually examine and also try to understand the neuropsychological functioning of people living with SLE. It serves as a good basis for future studies in this field. Further, aside anxiety and depression which has been reported extensively by previous studies as apparent in SLE (eg. Nicassio, et al., 2011; Bachen, et al., 2009; Kozora, et al., 2006), the current study also found somatisation, obsession-compulsion, interpersonal sensitivity, hostility, phobic anxiety and psychoticism to be prevalent in the Ghanaian population of SLE patients. Again, this study found that attention positively predicted quality of life in SLE.

Direction for future research

Based on the findings from the study, several recommendations are made in order to improve research in this area. There is a need for further research to look at the following areas:

- The cognitive and behavioural functioning can be assessed taking in to consideration some blood works like to detect glucose levels, haemoglobin and other blood related complications.
- This present study assessed patients just once on the cognitive and behavioural measures. Follow up longitudinal studies are needed in the future to evaluate the extent of cognitive deficits and also to assess whether the cognitive deficits get worse with time or improves.

- Brain imaging in the form of MRI and/or CT scans can be added as part of the data collection process to identify any brain or central nervous system abnormalities in SLE patients.
- Further, controls with other chronic conditions and/or neurological disorders can be compared to the SLE on neuropsychological measures.

Conclusion

Systemic lupus erythematosus (SLE, lupus) is a complex inflammatory disease with diverse clinical presentations, which is known to pose a lot of cognitive, behavioural and quality of life challenges. Although, the impact of SLE is known; much research has not been done in Ghana. Additional research on neurocognitive functioning and psychological wellbeing will boost the care of SLE patients in Ghana. This study assessed the neuropsychological functioning of SLE patients in Ghana.

A mixed-method approach was used to gather the data involving survey using 135 participants for the quantitative and in-depth interviews of 11 SLE patients for the qualitative. Among other objectives, the study first assessed the cognitive and psychological functioning of SLE patients compared to healthy controls. The study further examined any possible association between cognitive function and quality of life.

Results from the quantitative study showed that statistical differences existed between the SLE patients and the healthy control group on the cognitive measures, behavioural and quality of life.

Further, no statistically significant overall relationship was observed between the cognitive measures and quality of life but when the measures were considered individually, a positive association was observed between the test of attention and quality of life.

Furthermore, on the within group analysis, SLE patients who have lived with the condition for more than two years did not differ significantly on quality of life than those who have been living with the condition for less than two years.

Findings from the qualitative part showed that SLE patients have diverse challenges that has an impact on their quality of life. Challenges they encounter include physical, emotional, financial, issues with medication, challenges explaining the condition, fertility challenges and forgetfulness.

The findings further show that SLE patients receive emotional support, instrumental and informational support from loved ones.

Lastly, it can be observed from the findings that SLE patients use some coping strategies to help the cope better with the condition these include spiritual coping, inspiration from significant others, personal survival efforts, believe in the treatment and support group.

In conclusion, the findings from the study shows that a bio-psychosocial approach is needed in the management of SLE patients and people living with other chronic conditions in Ghana.

REFERENCES

- Abdou, N., Boucar, D., El Hadj Fary, K. A., Mouhamadou, M., Abdoulaye, L., Mamadou Mourtala, K. A.,...Therese, M. D. (2003). Histopathological Profiles of Nephropathies in Senegal. *Saudi J Kidney Dis Transpl*;14: 212-214. <http://www.sjkdt.org/text.asp?2003/14/2/212/33034>
- Adelowo, O. O., Oguntona, S. A. (2009). Pattern of systemic lupus erythematosus among Nigerians. *Clin Rheumatol*, 28: 699–703.
- Ashby, F. G., Isen, A. M., Turken, A. U. (1999). A neuropsychological theory of positive affect and its influence on cognition. *Psychol Rev*. 106: 529–50.
- Avina-Zubieta, J. A., Alarcon, G. S., Bischoff-Ferrari, H. A., Fischer-Betz, R., Schneider, M., Gall, V. et al (2007). Measurement of Fatigue in Systemic Lupus Erythematosus: A Systematic Review. *Arthritis & Rheumatism (Arthritis Care & Research)* vol. 57: 8, 1348–1357
- Bachen, E. A., Chesney, M. A., & Criswell, L. A. (2009). Prevalence of mood and anxiety disorders in women with systemic lupus erythematosus. *Arthritis Rheum*. 61(6), 822–829.
- Bartels, C. M. (2017). Systemic Lupus Erythematosus (SLE) clinical presentation. Retrieved from <https://emedicine.medscape.com>
- Barracough, M., Elliott, R., Parker, B., McKie, S., Jackson, A., Pemberton, P., & Bruce, I. N. (2019). Altered cognitive function in systemic lupus erythematosus and associations with inflammation and functional brain changes. *Arthritis Rheumatol*; 70

(10). <https://acrabstracts.org/abstract/altered-cognitive-function-in-systemic-lupus-erythematosus-and-associations-withinflammation-and-functional-brain-changes/>.

Barros, B. P., Souza, C. B., Kirsztajn, G. M. (2012). The structure of the “lived-experience”: analysis of reports from women with systemic lupus erythematosus. *Journal of Nursing Education and Practice*, 2: 3.

Benedict, R. H., Shucard, J. L., Zivadinov, R. & Shucard, D. W. (2008). Neuropsychological impairment in systemic lupus erythematosus: a comparison with multiple sclerosis. *Neuropsychology review*; 18(2):149-66. PubMed PMID: 18521755. Pubmed Central PMCID: PMC2572265. Epub 2008/06/04. eng

Bertsias, G., Cervera, R., Boumpas, D. T. (2012). Systemic Lupus Erythematosus: Pathogenesis and Clinical Features. Retrieved from www.eular.org.

Bhatt, S. P., Handa, R., Gulati G. S., Sharma, S., Pandey, R. M., Aggarwal, P.,... Shankar, S. (2007). Peripheral vascular disease in systemic lupus erythematosus. *Lupus*;16(9):7203.

Bongu, A., Chang, E., & Ramsey-Goldman, R. (2002). Can morbidity and mortality of SLE be improved? *Best Practices and Research in Clinical Rheumatology*, 16(2), 313-332.

Bonomi, A. E., Patrick, D. L., Bushnell, D. M., & Martin, M. (2000). Validation of the United States' version of the World Health Organization Quality of Life (WHOQOL) instrument. *J Clin Epidemiol*, 53(1):1-12.

Braun, V., & Clarke, V. (2006). Using thematic analysis in psychology. *Qualitative Research in Psychology*, 3, 77-101. doi:10.1191/1478088706qp0630a

- Broadbent, D. E., Cooper, P. F., FitzGerald, P., & Parkes, K. R. (1982). The Cognitive Failures Questionnaire (CFQ) and its correlates. *British Journal of Clinical Psychology, 21*, 1-16.
- Burgos, P. I., McGwin, G., Reveille, J. D., Vilá, L. M., & Alarcón, G. S. (2010). Factors predictive of thrombotic events in LUMINA, a multi-ethnic cohort of SLE patients. *Rheumatology;49(9):1720-5*.
- Butt, B. A., Farman, S., Khan, S. E. A., Saeed, M. A., & Ahmad, N. M. (2017). Cognitive dysfunction in patients with Systemic Lupus Erythematosus. *Pak J Med Sci; 33(1):59-64*. <http://doi: 10.12669/pjms.331.11947>
- Campbell, J., Rashid, W., Cercignani, M., & Langdon, D. (2017). Cognitive impairment among patients with multiple sclerosis: associations with employment and quality of life. *Postgraduate Medical Journal, 93:143-147*.
- Carver, C. S. (2011). Coping. In Contrada, R. J. & Baum, A. (Eds.), *The Handbook of Stress Science: Biology, Psychology and Health* (220-229). New York.
- Choi, J., Kim, S. T., & Craft, J. (2012). The pathogenesis of systemic lupus erythematosus—an update. *Current Opinion in Immunology, 24:651–657*
Retrieved from www.sciencedirect.com.
- Cohen, W. S., Roberts, W. N. & Levenson, J. L. (2004). Psychiatric aspects of systemic lupus erythematosus. *En Systemic Lupus Erythematosus (4th Edition)*. New York: Elsevier.
- Conti, F., Alessandri, C., Perricone, C., Scrivo, R., Rezai, S., Ceccarelli, F.,... Valesini, G. (2012). Neurocognitive dysfunction in systemic lupus erythematosus: association with

antiphospholipid antibodies, disease activity and chronic damage. *PLoS One.*;7(3):1-7. <http://doi:10.1371/journal.pone.0033824>

Creswell, J. W. (2013) *Qualitative Inquiry and Research Design*. Thousand Oaks, CA: Sage Publication.

Creswell, J. W. (2003). *Research design: Qualitative, quantitative and mixed methods approaches*. London: Sage Publications.

Creswell, J. W. (1998). *Qualitative inquiry and research design: Choosing among five traditions*. Thousand Oaks, CA: Sage Publications.

Cummings, J. L. (1995). Anatomic and behavioral aspects of frontal-subcortical circuits. *Annals of the New York Academy of Sciences*, 769(1), 1–14. doi: 10.1111/j.1749-6632.1995.tb38127.x

Delis, D. C., Kramer, J. H., Kaplan, E., & Ober, B. A. (2000). *The California Verbal Learning Test Second Edition*. San Antonio: The Psychological Corporation.

Denburg, S. D., Carbotte, R. M. & Denburg, J. A. (2008) Cognitive impairment in systemic lupus erythematosus: A neuropsychological study of individual and group deficits. *Journal of Clinical and Experimental Neuropsychology*, 9: 323-339

Denburg, S. D., Carbotte, R. M., & Denburg, J. A. (1997) Psychological aspects of Systemic lupus erythematosus: cognitivefunction, mood and self-report. *J Rheumatol*(5):998-1003.

Derogatis, L. R., & Melisaratos, N. (1983). The Brief Symptom Inventory: an introductory report. *Psychological Medicine*, 13 (3), 595-605.

- Dey, I. D., Boima, V., Atiase, Y., Yorke, E., Ganu, V. & Mate-Kole, C. C. (2015). Rheumatology in Ghana – A Paradigm Change. *Internal Medicine Practice in Ghana: Challenges, Innovations and Future Directions*, 7-21.
- Doria, A., Rinaldi, S., Ermani, M., Salaffi, F., Iaccarino, L., Ghirardello, A.,... Todesco, S. (2004). Health-related quality of life in Italian patients with systemic lupus erythematosus. I. Relationship between physical and mental dimension and impact of age. *Rheumatology (Oxford)*, 43(12): 1580-6
- El-Shafey, A. M., Abd-El-Geleel, S. M., & Soliman, E. S. (2012). Cognitive impairment in non-neuropsychiatric systemic lupus erythematosus. *Egypt Rheum.*; 34:67-73. doi: 10.1016/j.ejr.2012.02.002
- Espe-Pfeifer, P. & Wachsler-Felder, J. (2000). *Neuropsychological Interpretation of Objective Psychological Tests*. Springer. p. 160. ISBN 978-0-306-46224-5.
- Faller, G., Thomson, P.D., Kala, U.K., & Hahn, D. (2005). Demographics and presenting clinical features of childhood systemic lupus erythematosus. *S Afr Med J*; 95: 424–427.
- Federman, D. G., Tren, J. T., Froelich C. W., Demirovic, J., & Kirsner, R. S. (1998). Epidemiology of peripheral vascular disease: a predictor of systemic vascular disease. *Ostomy/wound management*; 44(5):58-62, 4, 6 passim. PubMed PMID: 9697547. Epub 1998/08/11. eng.
- Fredrickson, B. L., & Branigan, C. (2005). Positive emotions broaden the scope of attention and thought action repertoires. *Cognition and Emotion*, 19, 313-332.

- Folkman, S., & Lazarus, R. S. (1988). Coping as a mediator of emotions. *Journal of Personality and Social Psychology*, 54(3):466-75. [http://doi: 10.1037/00223514.54.3.466](http://doi:10.1037/0022-3514.54.3.466)
- Fortin, P. R., Abrahamowicz, M., Neville, C., du Berger, R., Clarke, A. E., & Danoff, D. (1998). Impact of disease activity and cumulative damage on the health of lupus patients. *Lupus*, 7, 101–107.
- García-Madruga, J. A., Gómez-Veiga, I. & Vila, J. Ó. (2016). Executive Functions and the Improvement of Thinking Abilities: The Intervention in Reading Comprehension. *Front. Psychol.* 7:58. [http://doi: 10.3389/fpsyg.2016.00058](http://doi:10.3389/fpsyg.2016.00058)
- Gladman, D. D., Ibañez, D. & Urowitz, M. B. (2002). Systemic lupus erythematosus disease activity index 2000. *The Journal of rheumatology*, 29(2):288-91.
- Gladman, D. D., Urowitz, M. B., Ong, A., Gough, J., & MacKinnon, A. (1996a). Lack of correlation among the 3 outcomes describing SLE: Disease activity, damage, and quality of life. *Clinical and Experimental Rheumatology*, 14, 305–308.
- Gladman, D. D., Urowitz, M. B., Ong, A., Gough, J., & MacKinnon, A. (1996b). A comparison of five health status instruments in patients with systemic lupus erythematosus (SLE). *Lupus*, 5, 190–195.
- Glanz B. I., Slonim D., Urowitz M. B., Gladman D. D., Gough, J. & MacKinnon, A. (1997). Pattern of neuropsychological dysfunction in inactive systemic lupus erythematosus. *Neuropsychiatry Neuropsychol Behav Neurol*;10(4):232-8.
- Greene J. C. (2007). *Mixed methods in social inquiry*. San Francisco: Jossey-Bass.
- Hahn, B. H. (2002). An overview of the pathogenesis of systemic lupus erythematosus. *In D. J. Wallace & B. H. Hahn (Eds.), Dubois' lupus erythematosus (6th ed., pp. 87-96)*. Philadelphia: Lippincott Williams & Wilkins.

- Hanly, J. G., Omisade A., & Fisk J. D. (2013). Psychopathology, Neurodiagnostic Testing, and Imaging In: Wallace D.J., Hahn B.H., editors. *Dubois' Lupus Erythematosus and Related Syndromes. 8th Edition. Philadelphia: Elsevier:382-390.*
- Hanly, J. G., Omisade, A., Su, L., Farewell, V., & Fisk, J. D. (2010). Cognitive Function In Systemic Lupus Erythematosus, Rheumatoid Arthritis And Multiple Sclerosis Assessed By Computerized Neuropsychological Tests. *Arthritis Rheum. ; 62(5): 1478–1486. doi:10.1002/art.27404.*
- Hanly, J. G, Urowitz M. B, Sanchez-Guerrero J., Bae S. C, Gordon C, Wallace D. J.,... Farewell, V. (2007). Neuropsychiatric events at the time of diagnosis of systemic lupus erythematosus: an international inception cohort study. *Arthritis Rheum. 56(1):265–73.[PubMed: 17195230]*
- Hayden, J. A. (2009). *Introduction to health behaviour theory*. Canada: Jones & Bartlett.
- Herndon, J. (2016). Systemic Lupus Erythematosus (SLE). Retrieved from <https://www.healthline.com>.
- Hendrie, H. C., Albert, M. S., Butters, M. A., Gao, S., Knopman, D. S., Launer, L. J.,... Wagster, M. V. (2006). The NIH cognitive and emotional health project: report of the critical evaluation study committee. *Alzheimer Dement; 2(1):12–32. http://doi: 10.1016/j.jalz.2005.11.004*
- Huerta, P. T., Gibson, E. L., Rey, C., Huerta, T. S., Huerta, P. T. (2015). Integrative neuroscience approach to neuropsychiatric lupus. *Immunol Res.;63(1-3):11–17. http://doi: 10.1007/s12026-015-8713-6.*
- Hughes, A. S., (2016). Mixed Method Research. Association for Psychological Science. Retrieved from <http://www.psychologicalscience.org>.

- Huppert, F. A. (2009). Psychological Well-being: Evidence Regarding its Causes and Consequences. *Applied Psychological : Health and well-being/1*, issue 2. <https://doi.org/10.1111/j.17780854.2009.01008.x>
- Isen, A. M., Rosenzweig, A. S. & Young, M. J. (1991). The influence of positive affect on clinical problem solving. *Med Decis Making*. 11(3):221–7.
- Jarpa, E., Babul, M., Caldero´, J., Gonza´lez, M., Marti´nez, M.E., Bravo-Zehnder, M.,... Massardo, L. (2011). Common mental disorders and psychological distress in systemic lupus erythematosus are not associated with disease activity. *Lupus* 20, 58-66. <http://lup.sagepub.com>
- Jennekens, F. G. I. & Kater, L. (2002). The central nervous system in systemic lupus erythematosus. Part 1. Clinical syndromes: a literature investigation. *Rheumatology*. 2002, 41(6):605-18.
- Jung, R. E., Segall, J. M., Grazioplene, R. G., Qualls, C., Sibbitt Jr, W. L., & Roldan, C. A. (2010) Cortical Thickness and Subcortical Gray Matter Reductions in Neuropsychiatric Systemic Lupus Erythematosus. *PLoS ONE*, 5(3): p. e9302.
- Keller, S. M., (1999). Social Support and Psychological Distress in Women with Systemic Lupus Erythematosus. Retrieved 5th April 2017 from
- Kirou, K. A., & Boumpas, D. T. (2002). Systemic glucocorticoid therapy in systemic lupus erythematosus. In D. J. Wallace & B. H. Hahn (Eds.), *Dubois' lupus erythematosus (6th ed., pp. 1173-1194)*. Philadelphia: Lippincott Williams & Wilkins.
- Kozier, B. & Erb, G. (2008). *Fundamentals of nursing – concepts, process and practice (9th ed.)*. New York: Addison-Wesley.

- Kozora, E., Arciniegas, D. B., Zhang, L., & West, S. (2007). Neuropsychological patterns in systemic lupus erythematosus patients with depression. *Arthritis Res Ther*; 9 R48.
- Kozora, E., Ellison, M. C. & West, S. (2006). Depression, fatigue, and pain in systemic lupus erythematosus (SLE): relationship to the American College of Rheumatology SLE neuropsychological battery. *Arthritis Rheum. 15;55(4):628-35*.PubMed.
- Krysta, K., Krupka-Matuszczyk, I., & Zawada, K. (2015). Anxiety, Depression and Cognition in Patients with Lupus Erythematosus. *European Psychiatry, 30*, Supplement 1, 28-31,pg613.
- Kuper, B. C., & Failla, S. (2000). Systemic lupus erythematosus: A multisystem autoimmune disorder. *Nursing Clinics of North America, 35(1)*, 253-265.
- LaRocca, M. A., & Scogin, F. R. (2015). The Effect of Social Support on Quality of Life in Older Adults Receiving Cognitive Behavioral Therapy. *Clin Gerontol. 1; 38(2): 131–148*.
- Lee, S. P., Wu, C. S., Hsieh, L. C., Cheung, W. K., & Chou, M. C. (2014). Efficacy of magnetic resonance diffusion tensor imaging and three-dimensional fiber tractography in the detection of clinical manifestations of central nervous system lupus. *Magn Reson Imaging ;32(5):598–603*. doi:10.1016/j.mri.2014.02.005 pmid:24629511
- Leslie, B., & Crowe, S. F. (2018). Cognitive functioning in systemic lupus erythematosus: a meta-analysis. *Lupus:0, 1–10*. Retrieved from <http://www.sagepub.co.uk/journalsPermissions.nav>
- Lezak, M. D., Howieson, D. B., & Loring, D. W. (2004). *Neuropsychological Assessment* (4th ed). New York: Oxford University Press.

Llewellyn, D. J., Lang, I. A., Langa, K. M., & Huppert, F. A. (2008). Cognitive function and psychological well-being: findings from a population-based cohort. *Age and Ageing, 37*(6)

Lupus Foundation of America (2018). International Survey shows low global understanding about lupus. Retrieved from <https://www.lupus.org/>. Retrived 20/February/ 2018.

Lupus International (2011). What is Cognitive Dysfunction? Retrieved from www.lupusinternational.com/About-Lupus-1-1/Cognitive-Dysfunction-.aspx.

Luria, A. R. (1973). *The Working Brain*. New York: Basic Books.

Mani, A., Shenavandeh, S., Sepehrtaj, S. S. & Javadpour, A. (2015). Memory and learning functions in patients with systemic lupus erythematosus: A neuropsychological case-control study. *The Egyptian Rheumatologist 37*, S13–S17, Shiraz, Iran.

Mathias, S. D., Berry, P., De Vries, J., Pascoe, K., Colwell1, H. H., Chang, D. J. & Askanase, A. D. (2018). Patient experience in systemic lupus erythematosus: development of novel patient-reported symptom and patient-reported impact measures. *Journal of Patient-Reported Outcomes, 2:11*. DOI 10.1186/s41687-018-0028-7

Mayo clinic (2017). Lupus- symptoms and causes. Retrieved from <https://www.mayoclinic.org>

McCune ,W. J., & Riskalla, M. (2002). Immunosuppressive drug therapy. In D. J. Wallace & B. H. Hahn (Eds.), *Dubois' lupus erythematosus (6th ed., pp. 1195-1217)*. Philadelphia: Lippincott Williams & Wilkins.

- K McElhone, K., Abbott, J., Gray, J., Williams, A., & Teh, L. S. (2010). Patient perspective of systemic lupus erythematosus in relation to health-related quality of life concepts: a qualitative study. *Lupus*, *v (19) issue 14* - journals.sagepub.com
- McElhone, K., Abbott, J., & Teh, L. S. (2006). A review of health related quality of life in systemic lupus erythematosus. *Lupus 15*, 633-643. www.lupus-journal.com.
- Molokhia, M., McKeigue, P. M., Cuadrado, M., & Hughes, G. (2001). Systemic lupus erythematosus in migrants from West Africa compared with Afro-Caribbean people in the UK. *Lancet* ; 357: 1414–1415.
- Morse, J. M. (1994). Designing funded qualitative research. In Denzin, N. K. & Lincoln, Y. S., *Handbook of qualitative research (2nd Ed)*. Thousand Oaks, CA: Sage.
- Murray, S. G., Yazdany, J., Kaiser, R., Criswell, L. A., Trupin, L., Yelin, E. H.,... Julian, L. J. (2012). Cardiovascular disease and cognitive dysfunction in systemic lupus erythematosus. *Arthritis care & research*, *64(9)*:1328-33. PubMed PMID: 22549897. Pubmed Central PMCID: PMC3705733. Epub 2012/05/03. eng.
- Nasreddine, Z. S., Phillips, N. A., Bedirian, V., Charbonneau, S., Whitehead, V., Collin, I., Cummings, J. L. & Chertkow, H. (2005). The Montreal Cognitive Assessment (MoCA): A Brief Screening Tool for Mild Cognitive Impairment. *Journal of the American Geriatrics Society*, *53*: 695-699.
- Nicassio, P. M., Carr, F. N., & Moldovan, I., (2011). An overview of psychological functioning in systemic lupus erythematosus. *Int. J. Clin. Rheumatol.* *6(5)*, 569–581.

- Nishimura, K., Omori, M., Katsumata, Y., Sato, E., Gono, T., Kawaguchi, Y.,... Ishigooka, J. (2015). The Neurocognitive Impairment in Corticosteroid-naive Patients with Active Systemic Lupus Erythematosus: A Prospective Study. *The Journal of Rheumatology*, 42 (3) 441-448; [http://doi: https://doi.org/10.3899/jrheum.140659](http://doi.org/10.3899/jrheum.140659).
- Olesinska, M., & Saletra, A. (2018). Quality of life in systemic lupus erythematosus and its measurement. *Reumatologia*, 1:45-54. Doi: <http://doi.org/10.5114/reum.74750>
- Onunkwor, C. I. (2010). *Assessment of knowledge about glaucoma amongst patients attending an eye clinic in Abuja, Nigeria*. Unpublished Thesis Work: University of South Africa, Department of Public Health.
- Onwuegbuzie, A. J., & Collins, K. M. (2007). A Typology of Mixed Methods Sampling Designs in Social Science Research. *The Qualitative Report*, 12(2), 281-316. Retrieved from <https://nsuworks.nova.edu/tqr/vol12/iss2/9>
- Osterrieth, P. A. (1944). The test of copying a complex figure: A contribution to the study of perception and memory. *Archives de Psychologie*. 30: 286–356.
- Pallant, J. (2011). *Spss Survival Manual. A step by step guide to data analysis using SPSS 4th edition*. Retrieved from <http://www.allenandunwin.com/spss>
- Pan, C.-W., Wang, X., Ma, Q., Sun, H.-P., Xu, Y., & Wang, P. (2015). Cognitive dysfunction and health-related quality of life among older Chinese. *Scientific Reports*, 5, 17301. <http://doi:10.1038/srep17301>
- Petri, M., Naqibuddin, M., Carson, K. A., Wallace, D. J., Weisman, M. H., Holliday, S. L.,... Brey, R. L. (2010). Depression and cognitive impairment in newly diagnosed systemic lupus erythematosus. *Journal of Rheumatology*, 37(10):2032-8.

- Petrus, N. G. & Winky, C. (2008). Group Psychosocial Program for Enhancing Psychological Well-Being of People with Systemic Lupus Erythematosus. *Journal of Social Work in Disability & Rehabilitation*, 6, - 3.
- Phuti, A., Schneider, M., Makan, K., Tikly, M. & Hodkinson, B. (2019). Living with systemic lupus erythematosus in South Africa: A bitter pill to swallow. *Health and Quality of Life Outcomes*; 17:65. <http://doi.org/10.1186/s12955-019-1132-y>
- Phuti, A., Schneider, M., Tikly, M., & Hodkinson, B. (2018). AB1442-HPR A misunderstood burden – living with SLE in South Africa. *BJM Journals Annals of the Rheumatic diseases* vol,77 issue 2.
- Prabu, V. N. N., Rajasekhar, L., Shanmukhi, Suvarna A., Agrawal, S., & Narsimulu, G. (2010). Severity of cognitive impairment in SLE is related to disease activity: single center case control study. *Indian Journal of Rheumatology* ;5(3):4. [http://doi: 10.1016/S0973-3698\(10\)60582-1](http://doi: 10.1016/S0973-3698(10)60582-1)
- Rees, F., Doherty, M., Grainge, M.J., Lanyon, P., & Zhang, W. (2016). The incidence and prevalence of systemic lupus erythematosus in the UK, 1999-2012. *Ann Rheum Dis* ;75(1):136 41
- Reitan, R. M., & Wolfson, D. (1985). *The Halstead-Reitan Neuropsychological Test Battery: Therapy and clinical interpretation*. Tucson, AZ: Neuropsychological Press.
- Ruff, R., Light, R., Parker, S., & Levin, H. (1996). Benton controlled oral word association test: Reliability and updated norms. *Archives of Clinical Neuropsychology*, 11(4), 329 -338

- Russell, C. K., & Gregory, D. M. (2000). Capturing day-to-day aspects of living with chronic illness: The need for longitudinal designs. *Canadian Journal of Nursing Research*, 32(3), 99-102.
- Scarmeas, N. & Stern, Y. (2003). Cognitive reserve and lifestyle. *J Clin Exp Neuropsychol*. 2003;25:625–33. [PMC free article] [PubMed]
- Scolding, N. J., & Joseph, F. G. (2002). The neuropathology and pathogenesis of systemic lupus erythematosus. *Neuropathology and applied neurobiology*.28(3):173-89. PubMed PMID: 12060342. Epub 2002/06/13. eng.
- Seeman, T. (2008). Support & Social Conflict. Retrieved from <https://Macses.ucsf.edu/research/psychosocial/socsupp.php>
- Semrud-Clikeman, M. & Ellison, P. A. T. (2009). *Child neuropsychology: Assessment and Interventions for Neurodevelopmental Disorders*, 2nd Edition. *Springer*, 171. ISBN 978-0-387-88963-4.
- Shakeri, H., Arman, F., Hossieni, M., Omrani, H.R., Vahdani, A., & Shakeri, J. (2015). Depression, Anxiety and Disease-Related Variables and Quality of Life Among Individuals With Systemic Lupus Erythematosus Living in Kermanshah Province, Iran. *Iran Red Crescent Med J*.;17(12): e31047. doi: 10.5812/ircmj.31047
- Shenton, A. K. (2004). Strategies for ensuring trustworthiness in qualitative research projects. *Education for Information*, 22(2), 63-75, doi: 10.3233/efi-2004-22201
- Shiel, W. C. Jr. (2018). Lupus (Systemic Lupus Erythematosus). Retrieved from <https://www.emedicinehealth.com>
- Somers, E. C., Marder, W., Cagnoli, P., Lewis, E. E., DeGuire, P., Gordon, C.,...McCune, W. J. (2014). Population-based incidence and prevalence of systemic lupus erythematosus: the Michigan Lupus Epidemiology and Surveillance program. *Arthritis Rheumatol*, 2014. 66(2): p. 369-78.

- Somers, T. J., Kurakula, P. C., Criscione-Schreiber, L., Keefe, F. J., & Clowse, M. E. B. (2012). Self-Efficacy and Pain Catastrophizing in Systemic Lupus Erythematosus: Relationship to Pain, Stiffness, Fatigue, and Psychological Distress. *Arthritis Care & Research*, 64, No. 9, pp 1334–1340. doi: 10.1002/acr.21686
- Spritzer, W. O., Dobson, A. J., Hall, J., Chesterman, E., Levi, J., Shepherd, R.,... Catchlove, B. R. (1981). Measuring the quality of life of cancer patients: A concise QL- Index for use by physicians. *Journal of Chronic Diseases*, 34, (12), 585-597.
- Stephens, A., Wardle, J. & Marmot, M. (2005). Positive affect and health-related neuroendocrine, cardiovascular, and inflammatory processes. *Proc Natl Acad Sci USA*.102:6508–12. [PMC free article] [PubMed].
- Strauss, E., Sherman, E. M. S., & Spreen, O. (2006). *A compendium of neuropsychological tests: administration, norms, and commentary (2nd ed.)*. Oxford: Oxford University Press.
- Stretton, J., & Thompson, P. J. (2012). Frontal lobe function in temporal lobe epilepsy. *Epilepsy Research*, 98(1), 1–13. [http://doi: 10.1016/j.eplepsyres.2011.10.009](http://doi:10.1016/j.eplepsyres.2011.10.009).
- Strecher, V. J. & Rosenstock, I. M. (1997). *The health belief model, in Health behaviour and health education: theory, research, and practice*. edited by Glanz, K., Lewis, F. M. & Rimer, B. K. (2nd ed.). San Francisco: Josey-Bass.
- Tabachnick, B. G. & Fidell, L. S. (2007). *Using multivariate statistics (5th edn)*. Boston: Pearson Education.
- Tashakkori, A. & Teddie, C. (2010). *SAGE Handbook of Mixed Methods in Social & Behavioural Research*. Thousand Oaks, CA, SAGE Publications, Inc. ISBN10: 1412972663.

- Téllez, A. & Sánchez, T. J. (2016). Luria's model of the functional units of the brain and the neuropsychology of dreaming. *Psychology in Russia: State of the Art*, 9(4).
- Thorne, S., McCormick, J., & Carty, E. (1997). Deconstructing the gender neutrality of chronic illness and disability. *Health Care for Women International*, 18, 1-16.
- Tiffin, N., Hodkinson, B. & Okpechi, I. (2014). Lupus in Africa: can we dispel the myths and face the challenges? *Lupus*. 2014 January 1, 2014;23(1):102-11.
- Tikly, M., Burgin, S., Mohanlal, P., Bellingan, A., & George, J. (1996) Autoantibodies in black South Africans with systemic lupus erythematosus: Spectrum and clinical associations. *Clin Rheumatol* ; 15: 261–265.
- Unterman, A., Nolte, J. E., Boaz, M., Abady, M., Shoenfeld, Y. & Zandman-Goddard, G.(2011). Neuropsychiatric syndromes in systemic lupus erythematosus: a meta-analysis. *Seminars in arthritis and rheumatism*. 2011 Aug;41(1):1-11. PubMed PMID: 20965549. Epub 2010/10/23. eng.
- Urowitz, M., Gladman, D. D., Ibanez, D., Sanchez-Guerrero, J., Bae, S. E., Gordon, C.,... Stoll, T. (2014). Changes in quality of life in the first 5 years of disease in a multicentre cohort of patients with systemic lupus erythematosus. *Arthritis Care Res (Hoboken)* 66(9):1374-9.<http://doi.10.1002/acr.22299>.
- Utset, T.O., Fink, J., & Doninger, N. A. (2006). Prevalence of Neurocognitive Dysfunction and Other Clinical Manifestations in Disabled Patients with Systemic Lupus Erythematosus. *The Journal of Rheumatology*; 33:3
- Vom Hofe, A., Mainemarre, G., & Vannier, L. (1998). Sensitivity to everyday failures and cognitive inhibition: Are they related? *European Review of Applied Psychology*, 48, 49-55.
- Wadee, S., Tikly, M., & Hopley, M. (2007). Causes and predictors of death in South Africans with systemic lupus erythematosus. *Rheumatology*. 2007;46(9):1487-91.

- Wallace, D. J. (2002a). Antimalarial therapies. In D. J. Wallace & B. H. Hahn (Eds.), *Dubois' lupus erythematosus (6th ed., pp. 1149-1172)*. Philadelphia: Lippincott Williams & Wilkins.
- Wallace, D. J. (2002b). The clinical presentation of systemic lupus erythematosus. In D. J. Wallace & B. H. Hahn (Eds.) *Dubois' lupus erythematosus (6th ed., pp. 621-628)*. Philadelphia: Lippincott Williams & Wilkins.
- Wallace, D. J., & Linker-Israeli, M. (1999). It's not the same old lupus or Sjogren's anymore: One hundred new insights, approaches, and options since 1990. *Current Opinion in Rheumatology, 11(5)*, 321-329.
- Wang, C., Mayo, N. E., & Fortin, P. R. (2001). The relationship between health related quality of life and disease activity and damage in systemic lupus erythematosus. *Journal of Rheumatology, 28*, 525-532.
- Ware, J. E. (1994). The status of health assessment. *An Rev Pub Health, 16*:237-354.
- Waterloo, K., Omdal, R., Husby, G., & Mellgren, S. I. (2009). Emotional Status in Systemic Lupus Erythematosus. *Scandinavian Journal of Rheumatology*
- Wechsler, D. (2008). *WAIS-IV administration and scoring manual*. San Antonio, TX: Psychological Corporation. WHO Constitution of the World Health Organization, Geneva, 1948.
- West, S. G. (2013). Clinical aspects of nervous system. In: Wallace D.J, Hahn B.H, editors. *Dubois' Lupus Erythematosus and Related Syndromes. 8th Edition. Philadelphia: Elsevier*;:368-381.
- Weiten, W., & Lloyd, M. A. (2008). *Psychology Applied to Modern Life (9th ed.)*. Wadsworth Cengage Learning. ISBN 0-49555339-5.
- Williams, A. M., Lindholm, J., Cook, D., Siddiqui, F., Ghanem, T. A., Chang, S. S. (2017). Association between cognitive function and quality of life in patients with head and

neck cancer. *JAMA Otolaryngol Head Neck Surg.*;143(12):1228–1235.

<http://doi:10.1001/jamaoto.2017.2014>

Williams, E. M., Bruner, L., Penfield, M., Kamen, D., & Oates, J. C. (2014). Stress and Depression in Relation to Functional Health Behaviors in African American Patients with Systemic Lupus Erythematosus. *Rheumatology (Sunnyvale)* 54: 005. doi:10.4172/2161-1149.S4-005

Wilson, I. B. & Cleary, P. D. (1995). Linking clinical variables with health-related quality of life: A conceptual model of patient outcomes. *Journal of American Medical Association*, 273 (1), 59-65.

World Health Organization (1948). *Preamble to the Constitution of the World Health Organization*. Geneva: World Health Organization.

World Health Organization (2001). *The World Health report- Mental health: New understanding, new hope*. Geneva: World Health Organization.

Wu, C. Y., Pan, A.W., Hsu, P. N., Chung, L., & Chen, T. J. (2016). The Predictive Models of Quality of Life for Individuals with Systemic Lupus Erythematosus – The Application of the Path Analysis. *Mental Health in Family Medicine* ; 12:262-271

Yousefi, K., & Weisman, M. H Y. (2002). Salicylate and nonsteroidal therapy. In D. J. Wallace & B. H. Hahn (Eds.), *Dubois' lupus erythematosus (6th ed., pp. 1141-1147)*. Philadelphia: Lippincott Williams & Wilkins.

Zaytseva, Y., Chan, R. C. K., Pöppe, E., & Heinz, A. (2015). Luria revisited: cognitive research in schizophrenia, past implications and future challenges. *Philosophy, Ethics, and Humanities in Medicine* 10:4 DOI 10.1186/s13010-015-0026-9

APPENDICES

APPENDIX I ETHICAL CLEARANCE



UNIVERSITY OF GHANA

ETHICS COMMITTEE FOR THE HUMANITIES (ECH)

P. O. Box LG 74, Legon, Accra, Ghana

My Ref. No.....

14th December 2018

Ms. Nora Nkornu
Department of Psychology
University of Ghana
P.O.Box LG25,
Legon

Dear Ms. Nkornu,

ECH 011/18-19: Neuropsychological Functioning in Systemic Lupus Erythematosus

This is to advise you that the above reference study has been presented to the Ethics Committee for the Humanities for a full board review and the following actions taken subject to the conditions and explanation provided below:

Expiry Date: 09/06/19
On Agenda for: Initial Submission
Date of Submission: 18/09/18
ECH Action: Approved
Reporting: Quarterly

Please accept my congratulations.

Yours Sincerely,

Prof. C. Charles Mate-Kole
ECH Vice Chair

Cc: Prof. Christopher Charles Mate-Kole, Department of Psychology, UG
Dr. Enoch Teye Kwadjo, Department of Psychology, UG
Prof. Joseph Osafo, Head of Department, Department of Psychology, UG



APPENDIX II

CONSENT FORM

UNIVERSITY OF GHANA



Official Use only
Protocol number

Ethics Committee for Humanities (ECH)

PROTOCOL CONSENT FORM

Section A- BACKGROUND INFORMATION

| | |
|---------------------------|--|
| Title of Study: | NEUROPSYCHOLOGICAL FUNCTIONING IN SYSTEMIC LUPUS ERYTHEMATOSUS |
| Principal Investigator: | NORAH NKORNU |
| Certified Protocol Number | |

Section B- CONSENT TO PARTICIPATE IN RESEARCH

General Information about Research

The purpose of this study is to examine and understand the neuropsychological functioning of individuals living with systemic lupus erythematosus (SLE). It would investigate the impact of cognitive and psychological functioning on the quality of life of SLE patients; as well as to explore the lived neuropsychological experiences of SLE patients, their knowledge about the illness and how they are coping with the condition.

The study will require that you complete some neuropsychological tests assessing skills necessary for adequate daily living such as executive functions, abstract reasoning, learning and memory, visual-spatial skills, motor abilities, verbal fluency as well as psychological functioning and quality of life. In total, participation in this study would last for about 1hour however, participants would be given intermittent breaks to reduce fatigue. In a situation whereby you cannot read, the researcher will be available to translate the material to a local dialect you understand in order to facilitate the process.

Benefits/Risks of the study

There is no risk associated with this study however, you may experience some tiredness. As such, all that is required of you is your availability and patience.

Although this study was not designed to benefit you directly, participants will have the opportunity of having neuropsychological screening at no cost to them.

Confidentiality

In order to ensure anonymity and confidentiality, you are not to write your name on the questionnaire, only your initials and contact number is required. Data will only be identifiable through randomly generated unique identification numbers assigned to each study participant. Information you share with the researcher would be termed as confidential and thus, information would not be released to a third party without your authorization. However, information may be released to your attending physician if you agree that this is done.

Compensation

Due to the academic nature of the present research, no extrinsic rewards would be given. However, snacks and water will be provided half way through the study since participants will spend about an hour at the research site.

Withdrawal from Study

Participation in this study is voluntary, you are not obliged by your physician or the researcher to partake in the research. As a result, there would be no consequences in situations whereby you decide not to participate or withdraw from the study. If you begin to participate in the research, you may at any time, for any reason, discontinue your participation without any negative outcomes.

Contact for Additional Information

You can contact the following for answers to any questions about the research.

Norah Nkornu, Mphil Clinical Psychology student of the University of Ghana, Post Office Box NT 771, Newtown-Accra. Contact: +233(0)244955863, email: nnkornu11@gmail.com. Also, if you have any questions about your rights as a research participant in this study you may contact the Administrator of the Ethics Committee for Humanities, ISSER, University of Ghana at ech@isser.edu.gh / ech@ug.edu.gh or 00233- 303-933-866.

| |
|----------------------------------|
| Section C- PARTICIPANT AGREEMENT |
|----------------------------------|

"I have read or have had someone read all of the above, asked questions, received answers regarding participation in this study, and am willing to give consent for me, my child/ward

to participate in this study. I will not have waived any of my rights by signing this consent form. Upon signing this consent form, I will receive a copy for my personal records."

Name of Participant

Signature or mark of Participant

Date

If participant cannot read and or understand the form themselves, a witness must sign here:

I was present while the benefits, risks and procedures were read to the volunteer. All questions were answered and the volunteer has agreed to take part in the research.

Name of witness

Signature of witness / Mark

Date

I certify that the nature and purpose, the potential benefits, and possible risks associated with participating in this research have been explained to the above individual.

Name of Person who Obtained Consent

Signature of Person Who Obtained Consent

Date

APPENDIX III

QUESTIONNAIRE

Demographics information

Initials..... Date Assessed.....

Age..... Subject I.D.....

Gender..... Handedness: circle: Right..... Left

Do you currently or have you experienced any of the following?

| Vision loss/ Glaucoma | No | Yes | No. of weeks | Currently has |
|-----------------------------------|----|-----|--------------|---------------|
| Hearing loss | | | | |
| Stroke | | | | |
| Head Injury | | | | |
| Attention/ concentration problems | | | | |
| Speech problems | | | | |
| Memory problems | | | | |
| Depression | | | | |
| Headaches | | | | |
| Heart diseases | | | | |
| Seizures | | | | |
| Malaria | | | | |
| Bp | | | | |
| Diabetes | | | | |
| Asthma | | | | |

Any history of a medical condition? Yes () No ()

If yes, specify.....

Are you currently on any medication? Yes () No () if yes,

specify.....

Do you take in alcohol? Yes () No () if you have stopped, when did you stop?.....

When did you start taking in alcohol?.....

How much alcohol do you take in a week?.....

Do you smoke? Yes () No ()

If yes then please answer the following questions

How many cigarettes per day?.....

When did you start smoking.....

If you have stopped, when did you stop?.....

We kindly request that you answer the following questions as truthfully as possible, all the answers that you provide are anonymous

DEMOGRAPHICS

1. Age.....
2. Gender: Male () Female: ().
3. Nationality
4. Ethnicity (Tick one): Akan () Ga/ Ga- Adangbe () Ewe () Northern Tribe () Non-Ghanaian () others() Specify.....
5. Religion (Tick one): Christianity () Islam () Traditional () Others () specify.....
6. Marital status: Married () Single () Separated/ Divorced () Widowed () Others () specify.....
7. Occupation? Employed () Unemployed () Retired () Student ()
8. Place of birth:
9. Highest level of education: Non formal education () Primary () Junior high school () Senior high school () Tertiary () Others
10. Number of years of education.....
11. Literacy; Can read or write English, Yes () No ()
12. Monthly Income.....

APPENDIX IV

INTERVIEW GUIDE

A) Subjective feelings of SLE patients

A1-Tell me about your life before you were diagnosed.

[probe: relationship with relatives, significant others, work, marriage].

A2-How have things been different when you were diagnosed?

[probe: difficulties with everyday activities, work, dependency, relationship with relatives and significant others; how they feel about it, stigma]

A3-What are the challenges you face being an SLE patient? probe: physical health, work, relationship with others, financial challenges

A4-How do you feel about your diagnosis?

A5-What are some of the support (social support) you have received?

[probe; family, NGO, government, others].

B) Coping strategies used by SLE patients

B1- How do you cope with the condition?

B2-What motivates you to keep living? [probe: religion, relationship with other SLE patients, relationship with family etc.]

APPENDIX V

Table 4.1: Summary of Means, SD, Reliability, Skewness and Kurtosis of Variables

| Instruments | M | SD | A | Skewness | Kurtosis |
|--------------|-------|-------|------|----------|----------|
| MOCA | 24.66 | 4.121 | .762 | -1.102 | 1.335 |
| CFQ | 30.69 | 14.47 | .921 | .795 | 1.030 |
| QOL | 9.49 | .888 | .447 | -1.717 | 2.213 |
| BSI | .489 | .476 | .934 | 1.908 | 4.905 |
| CVLT | 24.15 | 5.179 | .822 | -.287 | -.543 |
| REY | 22.89 | 8.169 | .766 | -.758 | -.150 |
| TRAIL | 65.47 | 64.53 | .831 | 2.45 | 7.856 |
| DIGIT SPAN | 15.80 | 3.32 | .760 | .118 | -.275 |
| COWAT | 13.98 | 5.183 | .903 | 1.704 | 11.54 |
| SPATIAL SPAN | 12.48 | 3.57 | .801 | .063 | -.801 |

N = 135

APPENDIX VI

Table 4.2: Pearson's correlation between psychological measure (BSI) and Quality of life.

| Variables | 1 | 2 | 3 | 4 | 5 | 6 | 7 | 8 | 9 | 10 | 11 |
|-----------|--------|--------|-------|--------|--------|-------|-------|--------|--------|--------|----|
| 1. DEP | 1 | | | | | | | | | | |
| 2. ANX | .64** | 1 | | | | | | | | | |
| 3. HOST | .64** | .69** | 1 | | | | | | | | |
| 4. SOMA | .61** | .66** | .52** | 1 | | | | | | | |
| 5. OBC | .60** | .67** | .62** | .66** | 1 | | | | | | |
| 6. PHOB | .55** | .64** | .48** | .37** | .52** | 1 | | | | | |
| 7. PAR | .46** | .48** | .44** | .26** | .56** | .55** | 1 | | | | |
| 8. PSY | .75** | .72** | .62** | .58** | .70** | .67** | .57** | 1 | | | |
| 9. IPS | .67** | .60** | .62** | .54** | .75** | .58** | .65** | .69** | 1 | | |
| 10. GSI | .81** | .86** | .77** | .75** | .86** | .71** | .68** | .86** | .83** | 1 | |
| 11. QOL | -.34** | -.32** | -.16 | -.42** | -.31** | -.16 | -.15 | -.25** | -.31** | -.36** | 1 |

NB: N=135. 1= Depression, 2= Anxiety, 3= Hostility, 4= Somatization, 5=Obsessive compulsion, 6=Phobic anxiety, 7= Paranoid ideations, 8= Psychoticism, 9=Interpersonal sensitivity, 10=Global severity index, 11=Spitzer's Quality of life. *p < 0.05 level (2-tailed)
 ** p < 0.01 level (2-tailed).

APPENDIX VII

Table 4.3: Pearson's correlation table of cognitive tests and psychological measure.

Table 4.3: Pearson's correlation table of Neuropsychological tests and BSI

| Variables | 1 | 2 | 3 | 4 | 5 | 6 | 7 | 8 | 9 | 10 | 11 | 12 | 13 |
|------------|--------|--------|--------|--------|--------|--------|--------|--------|--------|-------|-------|-------|----|
| CVLT IMM | | | | | | | | | | | | | |
| CVLT S.D | .70** | | | | | | | | | | | | |
| CVLT L.D | .70** | .83** | | | | | | | | | | | |
| REY COPY | .13 | .08 | .06 | | | | | | | | | | |
| REY IMM | .51** | .52** | .55** | .26** | | | | | | | | | |
| REY D.R | .46** | .51** | .55** | .27** | .93** | | | | | | | | |
| TMT | -.42** | -.46** | -.51** | -.08 | -.29** | -.27** | | | | | | | |
| DIGIT S. | .61** | .56** | .56** | .12 | .47** | .45** | -.42** | | | | | | |
| MOCA | .56** | .54** | .52** | .12 | .49** | .48** | -.31** | .54** | | | | | |
| CFQ | -.15 | -.19* | -.14 | -.04 | -.09 | -.11 | -.08 | -.19* | -.09 | | | | |
| COWAT | .56** | .52** | .52** | .11 | .47** | .43** | -.36** | .53** | .49** | -.17 | | | |
| SPATIAL S. | .68** | .55** | .60** | .28** | .57** | .55** | -.46** | .60** | .51** | -.09 | .50** | | |
| BSI (GSI) | -.42** | -.44** | -.45** | -.23** | -.34** | -.34** | .18* | -.35** | -.38** | .56** | -.29* | .41** | |

NB: N=135. 1= CVLT Immediate recall (trail 1-4), 2= CVLT. Short delayed recall, 3= CVLT. Long delayed recall, 4= Rey Copy, 5= Rey Immediate recall, 6=Rey Delayed recall, 7= Trail Making Test, 8= Digit span, 9=MOCA, 10=CFQ, 11=COWAT, 12=Spatial span, 13=Brief Symptom Inventory (Global severity index).

*p < 0.05 level (2-tailed) ** p < 0.01 level (2-tailed).

APPENDIX VIII

Table 4.4: Frequency and Percentages of Survey Participants SLE'S N= 70 and Healthy Controls (HC) N = 65)

| Variables | Category | Frequency/Percentage | |
|-------------------------------------|--------------|----------------------|----------------|
| | | SLE(70) | HC (65) |
| Gender | Male | 3(4.3) | 4 (6.2) |
| | Female | 67(95.7) | 61(93.8) |
| Age | 18-35 | 63 (90.0) | 63 (96.9) |
| | 36-49 | 7 (10.0) | 2 (3.1) |
| Mean age of groups | | 29.0 yrs (4.05) | 29.1yrs (4.39) |
| Number of years of education (mean) | | 13.67yrs | 14.52yrs |
| Occupation | Employed | 52(74.3) | 40(61.5) |
| | Unemployed | 8(11.4) | 6(9.2) |
| | Student | 9(12.9) | 19(29.2) |
| | Retired | 1(1.4) | 1(.7) |
| Religion | Christianity | 66(94.3) | 57(87.7) |
| | Islam | 4(5.7) | 8(12.3) |

Table 4.5: Summary of MANOVA results for neuropsychological measures

| Variables | SLE Patients | Healthy Controls | <i>F</i> | <i>p</i> | <i>η</i> ² |
|------------|------------------|------------------|----------|----------|-----------------------|
| | (<i>N</i> = 61) | (<i>N</i> = 62) | | | |
| MOCA | 22.51 ± 3.81 | 27.41(1.91) | 78.56 | .000 | .409 |
| CVLT IMM | 20.70 ± 3.97 | 27.98(3.25) | 128.99 | .000 | .506 |
| CVLT S.D | 5.39 ± 1.33 | 7.27(.853) | 83.64 | .000 | .419 |
| CVLT L.D | 4.77 ± 1.64 | 7.06(.990) | 83.73 | .000 | .423 |
| REY IMM | 18.14 ± 8.31 | 27.90(4.66) | 59.42 | .000 | .349 |
| REY D.R | 18.63 ± 7.82 | 26.51(4.74) | 41.58 | .000 | .272 |
| CFQ | 32.66 ± 15.74 | 28.85(11.46) | 2.87 | .128 | .019 |
| REY COPY | 35.29 ± 1.13 | 35.55(1.08) | 1.05 | .207 | .013 |
| SPATIAL_S | 10.11 ± 2.33 | 15.21(2.56) | 124.93 | .000 | .526 |
| DIGIT SPAN | 14.11 ± 2.73 | 17.85(2.64) | 56.15 | .000 | .336 |
| TMT | 81.43 ± 46.09 | 31.41(23.96) | 51.83 | .000 | .321 |
| COWAT | 11.11 ± 3.87 | 16.42(2.83) | 71.25 | .000 | .387 |

NOTE: MANOVA = multivariate analysis of variance; CVLT IMM= California Verbal Learning Test Trail 1-4; CVLT S.D= California Verbal Learning Test Short delayed recall; CVLT.L.D = California Verbal Learning Test Long delayed recall; Rey Copy; Rey Immediate recall; Rey Delayed recall; TMT = Trail Making Test; DIGIT S. = Digit span; MOCA = Montreal Cognitive Assessment; CFQ = Cognitive Failure Questionnaire; COWAT = Control Oral Word Association Test; Spatial S. = Spatial span.

Bonferroni's correction, $p < .004$

Table 4.6: Summary of MANOVA results for Behavioural measure and Quality of life

| Variables | SLE Patients | Healthy Controls | <i>F</i> | <i>p</i> | <i>η</i> ² |
|-----------|--------------|------------------|----------|----------|-----------------------|
| | (N = 66) | (N = 62) | | | |
| DEP | .661 ± .716 | .106 ± .224 | 34.14 | .000 | .213 |
| ANX | .629 ± .588 | .097 ± .226 | 44.47 | .000 | .261 |
| HOST | .596 ± .585 | .139 ± .179 | 34.81 | .000 | .216 |
| SOMA | .847 ± .741 | .151 ± .303 | 47.61 | .000 | .274 |
| OBC | .993 ± .791 | .435 ± .468 | 23.18 | .000 | .155 |
| PHA | .376 ± .589 | .077 ± .142 | 15.11 | .000 | .107 |
| PI | .956 ± .771 | .730 ± .532 | 3.68 | .057 | .028 |
| PSYC | .497 ± .698 | .084 ± .211 | 19.99 | .000 | .137 |
| IPS | .842 ± .765 | .399 ± .406 | 16.47 | .000 | .116 |
| QOL | 9.17 ± 1.02 | 9.82 ± .587 | 19.65 | .000 | .135 |

NOTE: MANOVA = multivariate analysis of variance; DEP = Depression; ANX = Anxiety; HOST = Hostility; SOMA = Somatization; OBC=Obsessive compulsion; PHA =Phobic anxiety; PI = Paranoid ideations; PSYC = Psychoticism; IPS =Interpersonal sensitivity; QOL= Quality of Life.

Bonferroni's correction $p < .005$

Table 4.7: Summary of Standard Multiple Regression for hypothesis three

| Model | B | Std. Error | β | t | p |
|--------------|----------|-------------------|---------------------------|----------|----------|
| 1 (constant) | 7.389 | 1.042 | | 7.091 | .000 |
| CVLT IMM | .001 | .039 | .006 | .038 | .970 |
| CVLT SD | -.060 | .129 | -.091 | -.462 | .646 |
| CVLT DR | .055 | .120 | .093 | .460 | .647 |
| REY IMM | .055 | .043 | .448 | 1.280 | .206 |
| REY DR | -.061 | .047 | -.461 | -1.306 | .197 |
| TRAIL | -.001 | .002 | -.084 | -.604 | .549 |
| DIGIT | .123 | .058 | .335 | 2.101 | .040* |
| MOCA | .022 | .042 | .083 | .520 | .605 |
| CFQ | -.012 | .008 | -.200 | -1.527 | .133 |
| COWAT | -.015 | .042 | -.056 | -.352 | .726 |
| SPATIAL S. | .040 | .060 | .091 | .667 | .508 |

Note: $R^2 = .23$, ($p < .05$), * $p < .05$

Table 4.8: Summary of t – test results on QOL between the newly diagnosed SLE patients and those who have lived with the condition for more than 2 years.

| Tests | Groups | N | Mean | SD | df | t | p |
|--------------|---------------|----------|-------------|-----------|-----------|----------|----------|
| QOL | 0-24 Months | 44 | 9.25 | .943 | 68 | .848 | .400 |
| | >24 Months | 26 | 9.04 | 1.11 | | | |