



Material flow analysis and risk evaluation of informal E-waste recycling processes in Ghana: Towards sustainable management strategies

Karoline Owusu-Sekyere^{a,*}, David Alatule Aladago^b

^a University of Stuttgart, Institute for Sanitary Engineering, Water Quality and Solid Waste Management, Bandtüle 2, 70569, Stuttgart, Germany

^b University of Ghana, Department of Geography and Resource Development, Legon, Ghana

ARTICLE INFO

Handling Editor: Giovanni Baiocchi

Keywords:

E-Waste
Informal sector
Informal recycling processes
Ghana

ABSTRACT

Informal electronic waste (e-waste) recycling plays a significant role in e-waste management in developing countries, such as Ghana, where over 90% is handled by the informal sector. However, the informal treatment of e-waste poses a risk to human health and the environment due to the release of toxic pollutants. There is a lack of data on e-waste management and informal processing, and the material flows of output fractions and the fate of hazardous fractions are largely unknown. This hinders the development of appropriate management strategies. Herein, Material Flow Analysis (MFA) was used to investigate five important informal e-waste recycling processes, and risk analysis was used to evaluate environmental, economic, and health safety. On average of all assessed processes, 40.3% of the emerging fractions are landfilled or burned whereof the processing of ICT appliances (desktop PC, laptops and phones) (P1) contributes with 19.4%, CRT appliances (P2) with 11.7%, compressors from cooling appliances (P3) with 0.1%, microwaves (P4) with 1.3% and printers (P5) with 7.7% to the landfilled or burned fractions. The risk assessment showed that there are considerable risks in environmental, economic and health safety for all processes. When considering the overall risk assessment across all categories, the priority for action to have the most substantial impact is as follows: P2>P5>P3>P1>P4. The key findings of this research focus on the assessment of the so far not known informal e-waste process workflows, the identification of emerging fractions, the remain of potentially hazardous fractions and the identification of the primary economic drivers in informal e-waste dismantling. Recommended action areas involve the incorporation of the informal sector, guided by the insights derived from the MFA and risk assessment. The results of this study are of importance for addressing the challenges faced by the informal sector and for making well-informed decisions when strategizing e-waste management infrastructure.

1. Introduction

Electronic waste (e-waste) is the fastest-growing waste stream worldwide (Forti et al., 2020). Developing countries are experiencing an increase in the volume of e-waste due to population growth, increasing prosperity, and increased demand and supply of electrical and electronic equipment (EEE) (Asante et al., 2019; Daum et al., 2017; UNEP, 2018). E-waste in African countries accounts for 50–85% of the e-waste generated in Africa, while illegal imports make up the rest (Baldé et al., 2022; Schlupe et al., 2012). West African nations, in particular Ghana and Nigeria, exhibit a notable level of direct imports of used EEE. This serves as the primary channel for the introduction of functional used EEE and e-waste into the African continent. (Odeyingbo et al., 2017; Schlupe et al., 2012). The average annual per capita of e-waste

generated in Africa is 2.5 kg, much lower than that in Europe (16.2 kg per capita). However, only 0.9% of the e-waste that undergoes formal collection and recycling in Africa has been documented, and little is known about the treatment of e-waste in the informal sector (Forti et al., 2020).

E-waste encompasses both hazardous and valuable materials. Given the substantial intrinsic value of valuable materials like copper, aluminium, iron and gold found in e-waste, recycling for the purpose of recovering these components is attractive. However, electronic products are not engineered to facilitate the efficient retrieval of these materials or their safe disposal (Heacock et al., 2016). The environmentally sound end-of-life management and treatment of e-waste requires high technical standards because of the hazardous chemical compounds found within them. Unregulated treatment threatens the environment, ecosystems, and human health through the potential release of pollutants,

* Corresponding author.

E-mail address: Karoline.Owusu-Sekyere@iswa.uni-stuttgart.de (K. Owusu-Sekyere).

<https://doi.org/10.1016/j.jclepro.2023.139706>

Received 14 June 2023; Received in revised form 19 October 2023; Accepted 7 November 2023

Available online 13 November 2023

0959-6526/© 2023 The Authors. Published by Elsevier Ltd. This is an open access article under the CC BY license (<http://creativecommons.org/licenses/by/4.0/>).

Abbreviations

EEE	Electrical and electronic equipment
e-waste	Electronic waste
CRT	Cathode ray tube
ICT	Information and communication technology
MFA	Material flow analysis
PCB	Printed circuit boards

such as heavy metals, flame retardants, and dioxins (Achillas et al., 2013; Kyere, 2016; Tsydenova and Bengtsson, 2011). These high technical requirements are not met by most developing countries, and regulations for environmentally sound treatments during the recovery of valuable fractions and the enforcement of these regulations are lacking (Ikhlalayel, 2018; Tsydenova and Bengtsson, 2011). Lack of appropriate infrastructure for secure processing results in the informal sectors involvement where crude recycling methods such as manual dismantling, draining, open burning, and dumping of residues are adapted (Amoyaw-Osei et al., 2011). These methods generate substantial environmental pollution and cause severe health hazards, including the bioaccumulation of toxic materials due to high exposure to chemicals (Igharo et al., 2014). The distribution of pollutants through the air, waterbodies, and dust leads to them spreading, which may cause harm to areas beyond where the informal e-waste processing occurred (Sepúlveda et al., 2010).

1.1. The informal e-waste sector in Ghana

The informal sector plays a major role in waste management in most developing countries such as in Ghana, in terms of economic development, innovation, adaptability, job creation, poverty alleviation, and environmental management (Oteng-Ababio et al., 2014). It consists of small-scale enterprises, is labour-intensive and often low-paid, uses adapted technology, and is described as unorganised or unplanned and unregistered or unregulated work (Wang et al., 2020; Wilson et al., 2006). In Ghana, 93–97% of e-waste collection and recycling occurs in the informal sector, specifically in unregulated scrapyards, such as the Agbogbloshie Scrapyard (Amoyaw-Osei et al., 2011; Kyere, 2016; Schlupe et al., 2012). However, the informal sector is important because of its scale, wide geographical spread, and network-like structure, which yields high e-waste collection rates (Amoyaw-Osei et al., 2011). E-waste is usually purchased by the informal sector through itinerant waste buyers who perform door-to-door collection or purchase e-waste from households, businesses, or public institutions (Amoyaw-Osei et al., 2011; Forti et al., 2020; Kumi et al., 2019). Ghana's e-waste management sector comprises a countrywide network of informal collectors, intermediaries, scrap dealers, and dismantlers that specialise in manual disassembly, with the same techniques and structures (with some variation) being adopted throughout the network (Kumi et al., 2019).

Informal e-waste management represents an important source of income for the local population, where waste pickers earn far more than the minimum wage in Ghana (Oteng-Ababio, 2012). About 93% of the informal waste workers are from the northern part of Ghana, where most of the population lives below the poverty line of \$1.25 a day (Akormedi et al., 2013; Asibey et al., 2022; Oteng-Ababio et al., 2013). Under consideration of the Sustainable Development Goal 1 by the United Nations: End poverty in all its forms everywhere, extreme poverty where people live on less \$1.25 a day needs to be eradicated until 2030 (UN DESA, 2023).

The informal sector is often viewed negatively in many countries. However, it's important to recognize that informal recycling systems can be highly effective (Oteng-Ababio, 2012; Wilson et al., 2006). In developing countries, it's crucial to recognize that simply replicating

waste management approaches from more economically developed countries may not be suitable for all contexts (Wilson et al., 2006). To encourage decision makers and the public to transition from their dismissive and unfavourable views of the informal recycling sector to approaches that include constructive integration with the formal waste management system, it's vital to assess and comprehend the economic, social, and environmental advantages that emerge from informal recycling (Wilson et al., 2006, 2013). To facilitate integration, one effective approach is to collaborate with the informal sector, aiding them in self-organisation and adding value to their recycled materials, ultimately extracting higher value from recovered materials (Dhillon and Sandhu, 2017; Scheinberg et al., 2016; Wilson et al., 2006, 2013). From this point of view, the informal sector in Ghana must be considered when fostering sustainable waste-management practices and cannot be neglected or eradicated in future.

A clear legal framework for collection and recycling, the Hazardous and Electronic Waste Control and Management Act 917 (2016), the Legal Instrument (LI) 2250 (2016) and the Technical Guidelines (2018), was passed by the Ghanaian government to systematically address these realities (Kumi et al., 2021; Lambert et al., 2018; Republic of Ghana, 2016). Ghana's informal sector should participate in environmentally sound e-waste management initiatives for collection, aggregation, dismantling, recycling, and final disposal by obtaining an environmental permit from the EPA to carry out these activities (Lambert et al., 2018). However, strategies that incorporate the informal sector are rare, and no practical approach has been proposed (Kumi et al., 2021).

1.2. Problem statement and barriers for sustainable e-waste management

The informal handling of e-waste and recycling activities present significant health hazards and contribute to environmental pollution. At the same time, the informal sector helps fill a critical gap in e-waste management infrastructure, as the presence of e-waste in the informal setting and on landfills highlights the absence of formal recycling facilities (Amankwaa, 2014; Owusu-Twum et al., 2022).

Having reliable data on the quantities and movement of e-waste is indispensable for assessing development strategies, and establishing and implementing sustainable management approaches (Forti et al., 2020). However, large data gaps related to e-waste management in the informal sector in Africa exist (Forti et al., 2020; Liebmann, 2015; Maes and Preston-Whyte, 2022). Most studies on the impacts of e-waste recycling were conducted in Asia, particularly India and China. Consequently, data for the African context is scarce (Heacock et al., 2016; Sepúlveda et al., 2010; UNEP, 2018). Currently, official statistics, sales numbers or other data suitable for calculating the mass and material flows of e-waste and its fractions after treatment do not exist for Ghana (Forti et al., 2020; Kumi et al., 2019). Therefore, the volume and remain of valuable materials and hazardous fractions after e-waste is informally dismantled is largely unknown. Management and recycling strategies and the output fractions of e-waste recycling vary depending on the type of e-waste being recycled and a sustainable e-waste management system requires recycling methods that are tailored to the specific needs of a region (Liu et al., 2023; Van Yken et al., 2021).

As a result, the lack of robust data that both, the private and public sectors can use, hinders the planning, financing, and development of environmentally responsible e-waste processing initiatives. This gap in data, including the activities of the informal sector, has been noted in various studies (Daum et al., 2017; Forti et al., 2020; Maes and Preston-Whyte, 2022; Shittu et al., 2021). Furthermore, tools like Life Cycle Assessment (LCA), which are crucial for quantifying the environmental impact of products, require detailed and quantitative data on associated processes. Unfortunately, such data is often lacking in the informal sector, causing uncertainty for decision-makers seeking to address environmental and health concerns associated with informal e-waste management while adhering to circular economy principles (Kahhat and Williams, 2012). To make informed decisions, a

comprehensive understanding of informal e-waste recycling processes and their interconnections along the entire chain is essential.

Further major key barriers that affect the adoption of sustainable e-waste management are economic and financial limitations, international trade treaties, the lack of environmental laws and regulations and lack of appropriate infrastructure (Adanu et al., 2020; Chen et al., 2020; Islam and Huda, 2019). Most of the named barriers are ground in the lack of data and knowledge about the informal e-waste treatment system (Ismail and Hanafiah, 2021; Wang et al., 2013). This emphasizes the importance of generating and evaluating data of informal e-waste treatment processes for effective management. To maximize the impact on system enhancement taking into account the limited availability of resources in developing countries, it's crucial to identify specific processes or fractions responsible for the most severe impacts.

1.3. Objective of the research

This study addresses the issue of lack of available data in the informal e-waste recycling sector in Ghana. Its primary goal is to provide essential data, serving as a foundation for informed decisions concerning the enhancement of the informal e-waste recycling sector through integration, specifically for the assessed processes. Integrating the informal e-waste sector holds significant importance, offering both efficiency in resource recovery and income opportunities for impoverished communities (Oteng-Ababio, 2012; Wilson et al., 2013). Nevertheless, a pivotal question remains: Can this integration extend to all facets of e-waste recycling? Unlike other waste streams, the informal recycling of e-waste presents formidable environmental and health risks, chiefly due to the release of hazardous pollutants.

The essential data is assessed through field studies, supporting the MFA approach and risk assessment, which can assist stakeholders and decision makers in Ghana in formulating sustainable e-waste management strategies that prioritize the integration of the informal sector. In particular, we address the following main objectives within our study: a) Identifying and modelling of local informal e-waste treatment processes and waste fractions with the highest environmental and health impacts; b) Examining resource gaps that hinder circular economy pathways; c) Identifying the financial driving force within the informal sector and assessing its sustainability; d) Providing basic data to support stakeholders and decision makers in management strategies and integration of the sector.

The selected recycling processes and technologies are common processes in the informal sector and occur in all scrap yards in Ghana in a similar way. Thus far, the dataset included here is the only one that depicts selected processes and dependencies in the informal sector in Ghana, providing relevant data for initiating an environmentally sound e-waste management system.

2. Materials and methods

In this research, we adopted a mixed-method approach, integrating quantitative techniques like sorting analysis with qualitative methods such as participant observation and interviews (Creswell and Creswell, 2017). The use of quantitative and qualitative data analysis methods ensured a thorough assessment of informal e-waste recycling practices, leaving no important aspects unexplored. Our research's methodological framework collectively contributed to a robust analysis of informal e-waste recycling, enabling informed decision-making for sustainability in this specific context. This approach consists of four steps: (1) selecting which device-type recycling processes should be assessed based on a literature review and field studies, (2) conducting surveys and interviews in the informal sector based on participant observation, (3) sorting analysis of e-waste devices in the informal sector, and (4) data analysis in form of a Material Flow Analysis (MFA), an economical assessment and risk assessment for sustainability risks, (5) evaluation of the results.

2.1. Selection criteria for processes

Numerous types of e-waste are treated in Ghana's informal sector. Informal workshops usually dismantle only a specific type or device group of e-waste (Amoyaw-Osei et al., 2011). The study area included 50 small, informal workshops performing specific device-type recycling processes. These workshops were representational as the e-waste treatment technology is typical for local informal e-waste dismantling. The technologies used are the same countrywide, since the informal sector is well connected among each other (Amoyaw-Osei et al., 2011; Asibey et al., 2022; Kumi et al., 2021). Data was collected at informally operated scrapyards in Accra and Kumasi (Fig. 1).

In the pursuit of assessing the informal e-waste system and its impacts, the choice of device-type recycling processes for assessment in this study was crucial, with the selection process guided by specific considerations. Given that certain processes yield limited stream volumes and some e-waste categories are less commonly encountered in Ghanaian scrapyards, a literature review and participant observation field study were conducted to gather comprehensive information about the end-of-life devices that enter the informal sector. The criteria for selecting processes were as follows: The selected processes must a) be performed frequently and, therefore, produce a considerable volume; b) have a major economic influence on Ghana's informal sector; and c) be environmentally relevant or pose health threats.

The process selection was also intended to reflect the spectrum of local collection groups by representing at least one of the local recycling system-relevant devices in each group. Legal frameworks and collection groups generally do not participate in the informal sector. However, the existing legal framework should be considered for the subsequent management. The collection groups in Ghana are defined in Act 917, the LI 2250 and "Technical Guidelines on Environmentally Sound E-Waste Management for Collectors, Collection Centres, Transporters, Treatment Facilities and Final Disposal in Ghana" (Lambert et al., 2018).

This study investigated five important informal e-waste recycling processes (Table 1). First, ICT dismantling is popular in the informal sector because of the valuable metals, printed circuit boards (PCBs), and spare parts found in the devices. Second, cathode ray tube (CRT) devices dismantling is common in the informal sector but will likely decline because CRT devices are no longer being produced. This process poses health risks and produces environmentally relevant substances, such as lead glass and brominated plastics. Compressor dismantling from refrigerators and ACs. This is the most common process in Ghana's informal e-waste sector. The release of oil to the environment is likely during this process. Fourth, the processing of household devices is predominantly represented by microwave dismantling in Ghana. Larger household appliances such as washing machines and electrical stoves are not widely spread within the normal population and even decrease by 70% the more rural the area gets (Amoyaw-Osei et al., 2011). Finally, printer dismantling is performed in large quantities, releasing ink and cartridges with high pollution potential. In this study we focused on the locally used electrical and electronic devices and therefore locally generated e-waste, as there is no conclusive evidence suggesting a direct flow of e-waste from ports to scrapyards for recycling purposes. Typically, e-waste undergoes repair or utilizes spare parts before being recycled. This viewpoint is corroborated by the "Person in the Port Project," which indicates that the primary motive behind importing e-waste to Nigeria is for reusability, owing to the greater market value of refurbished products compared to recycling in the originating country (Odeyingbo et al., 2017).

2.2. Data collection

In this section, we outline the methodology employed for our field study and participant observation, a critical component of our data collection process. To develop data collection and qualitative interview guidelines, the results obtained from the observations and activities of

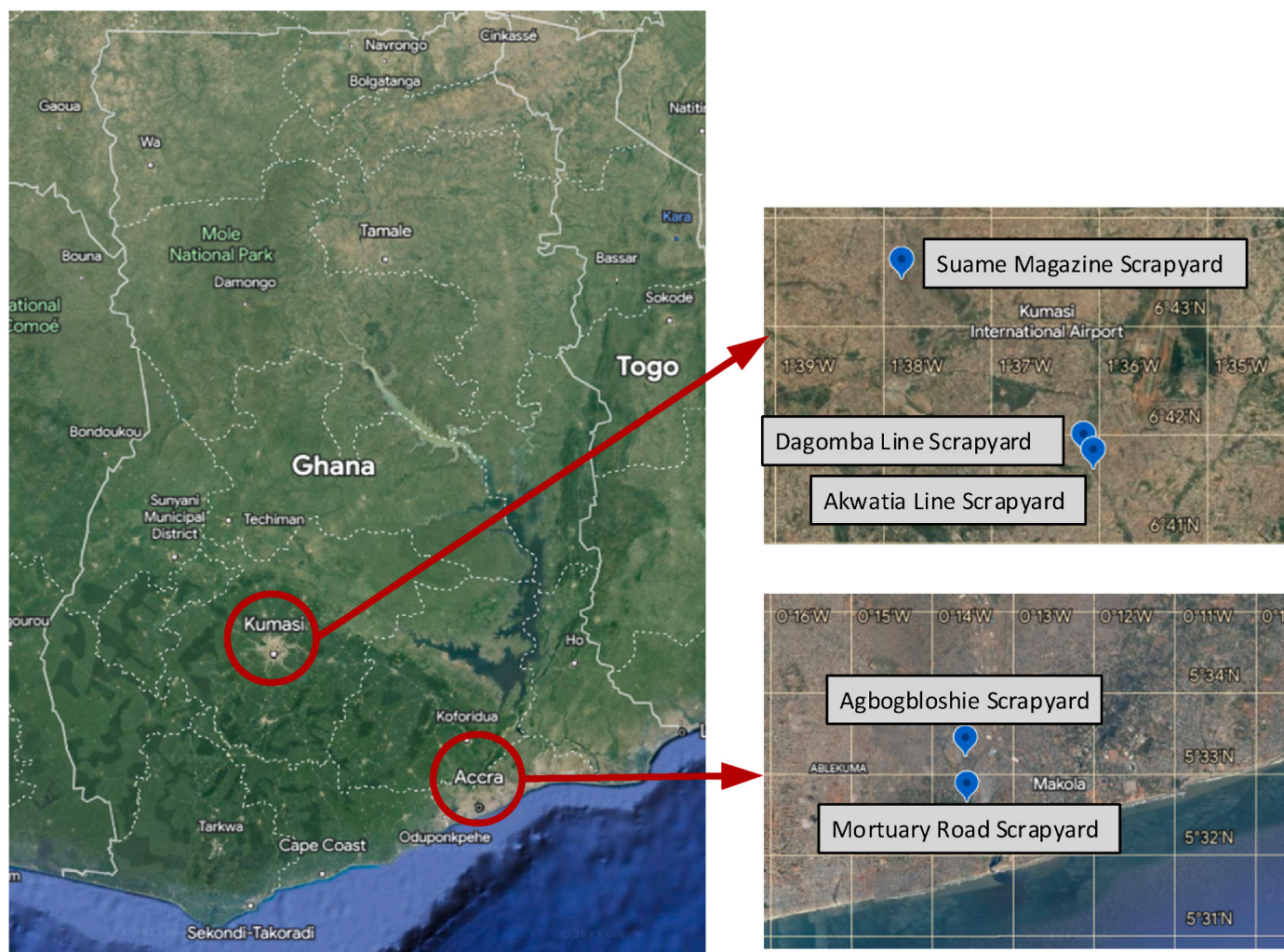

Fig. 1. Study area: surveyed informal scrapyards in Accra and Kumasi.

Table 1
List of selected processes.

Process No.	Process Name
1	ICT (Desktop-PC, Notebook and Phone) dismantling
2	CRT (-monitors and -TVs) dismantling
3	(Fridge and AC) Compressor dismantling
4	Microwave dismantling
5	Printer dismantling

participants were assessed, enabling a comprehensive understanding of the informal e-waste system (Kawulich, 2005). The data obtained during the field study are shown in Fig. 2.

2.2.1. Field study through participant observation

Participant observation is a qualitative method, well-suited for recording and understanding processes in the informal sector, and it provides the context for developing interview and sampling guidelines (DeWalt and Kathleen Musante DeWalt, 2010). By combining participant observation with other qualitative and quantitative techniques like interviews and sorting analysis, we aimed to enhance the overall validity of this study.

During the observational phase, the researchers engaged in orienting walks, dedicating a minimum of two days to acquaint themselves with scrapyards and their surroundings before commencing data collection. Ongoing informal recycling processes, interactions between workshops,

and the transportation of goods were observed and recorded. Relationships with informal workers and workshop owners were established, which is an important step in data collection within the informal sector, as mistrust may lead to obtaining false data during interviews (Owusu-Sekyere et al., 2022). The data obtained from the participant observation were analysed. Based on this, an interview guideline and a rapid data collection sheet for the processes were compiled.

2.2.2. Field study through interviews and measurement

During the second step of data collection, the researchers interviewed 50 individual workshops involved in the various dismantling processes of the e-waste value chain in scrapyards, focusing on the most relevant workshops in terms of size and implementation. The interviews were conducted primarily on workshop owners. Measurements of e-waste with the researchers own equipment, encompassing weight, size, and various attributes (Fig. 2), were conducted during and following the dismantling process. These measurements served to validate the information obtained through interviews and were recorded using a data-entry sheet. The brief description of processes, the required time per appliance, output fractions, the number of workers involved, safety measures applied, and estimated total number of workshops required for a process type at the scrapyard were noted. Also, the processes were filmed to acquire a better understanding of the workflow. Material flows between the workshops and economic parameters such as the purchase prices of e-waste, cost of labour, and selling prices of output fractions were documented. The data for Process 1 were collected separately for

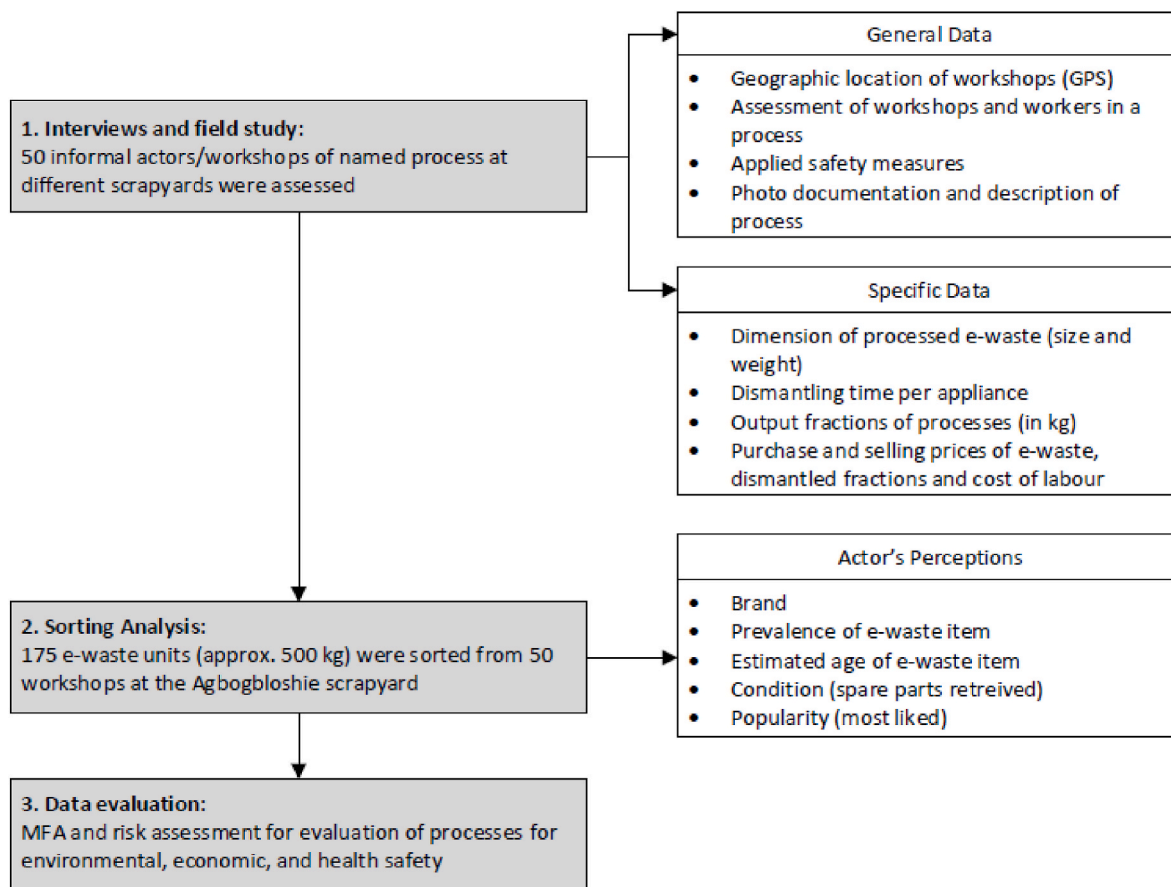

Fig. 2. Data collected data during the field study.

mobile phones, laptops, and desktop computers, as those represent the major composition of ICT devices according to our research in the previous participant observation. The reliability of the collected data was enhanced by carrying out random crosschecks during field visits or conducting supplementary interviews as necessary.

2.2.3. Sorting analysis of e-waste

A total of 175 e-waste units, corresponding to a total mass of approximately 500 kg, from the 50 different workshops selected for the field study were sorted. The age, brand, and popularity of the dismantled e-waste devices were estimated based on the sorting analysis and interview results. The participants' perceptions of the prevalence, estimated age (if the manufactured date was unavailable), condition (whether spare parts were scavenged from the e-waste), and popularity of each e-waste type were also assessed.

2.3. Data evaluation

The results obtained from the field study were methodically structured and subjected to analysis, involving the use of MFA, Microsoft Excel for economic evaluation, and the assessment of age distribution. This evaluated dataset is the foundation for the subsequent risk assessment, which aimed to evaluate the sustainability risks associated with the existing informal e-waste system.

2.3.1. Material flow analysis (MFA)

Material Flow Analysis (MFA) is an extensively studied and commonly applied method used for characterizing the movement and accumulation of substances or materials within a system (Brunner and Rechberger, 2004; Duygan and Meylan, 2015; Ismail and Hanafiah, 2021; Seigné-Itoiz et al., 2015). In this research, we employed a

simplified version of MFA, where a standardized input of one ton of material was used to elucidate and enhance our understanding of the output and residual fractions associated with the processes. Each selected process acted as the system boundary. The data collected during the field study, which included measurements of device weights and the quantities of emerging valuable and waste fractions, served as the input for the MFA. Weighted-mean average values were used to calculate the average output fractions per process and device. Specifically, we scaled the averages to represent one ton of input material. The outcomes of the MFA regarding the emerging fractions, particularly concerning their fate, whether they are collected for downstream processing, burned or landfilled, are a significant factor in risk assessment process.

2.3.2. Economic assessment and age distribution of e-waste

The findings derived from the sorting analysis, interviews, and participant observation were systematically organized and analysed using Microsoft Excel. Additionally, economic data, encompassing both revenue and costs, were computed for each individual process. Furthermore, with regard to the age structure of sorted devices, average ages were determined for each group. These outcomes play a critical role in shaping the economic criteria used for risk assessment.

2.3.3. Risk assessment

Evaluating risks associated with e-waste treatment is essential for sustainable e-waste management (Kazancoglu et al., 2022; Zhao et al., 2015). Hence, a risk analysis was conducted to evaluate the hazards of various processes and their acceptability concerning potential adverse impacts on the environment, economic conditions, and health safety.

Our approach draws upon the works of Dumay and Hossain (2019); Kazancoglu et al. (2022) and Wang et al. (2022), which emphasize the significance of sustainability risk assessment in corporate settings,

particularly in the realm of e-waste management. By incorporating the principles outlined by *Soyer et al. (2023)*, we were able to effectively identify, evaluate, and summarise risk criteria associated with diverse aspects of e-waste management. The urgency of the need for action for the individual processes was derived from this outcome.

Our method employed a comprehensive approach, integrating data from the field study in form of participant observation, interviews, sorting analysis, literature review, and expert insights. It also integrated the data evaluation, which entailed conducting MFA and economic assessment. This comprehensive process was instrumental in the selection of relevant risk criteria. Criteria such as revenue generation, market risk, disposal cost, ergonomic risk, accident risk, environmental toxins, water pollution, air pollution, and soil contamination were meticulously curated, aligning with findings by several studies as described in *Table 3*.

Risks were meticulously evaluated through the application of a 5 × 5 risk matrix (*Table 2*). We employed a comprehensive scoring system, aligning the likelihood and impact of each risk criterion within the matrix, based on the severity and probability of adverse effects. The researchers derived score ratings by analysing the data obtained through the field study and its subsequent evaluation based on the specified criteria. The final step involved summarising the risk ratings for each assessed process, categorizing the outcomes per category, including economic safety, health safety, and environmental safety.

This approach enabled us to gauge the urgency of action required for each process, ensuring a more targeted and effective sustainability management strategy. It is important to note that this methodology, while comprehensive, operates within the qualitative realm of sustainable risk assessment, and as such, involves inherent uncertainties and subjectivities. Despite these limitations, the method provides a robust framework for the holistic evaluation of sustainability risks associated with e-waste management, thus facilitating informed decision-making and proactive risk mitigation strategies.

3. Results

3.1. General description of the informal recycling system

Dismantling activities occur in informal workshops led by owners who employ young men to conduct the dismantling activities. Owners supervise the dismantling and are responsible for buying and selling e-waste and its output fractions. Ongoing dismantling activities depend on the availability of e-waste and are conducted mainly in the morning, when temperatures are cooler. E-waste from door-to-door collection is stored until it has both accumulated to a large quantity and is worth the labour cost for dismantling. Valuable fractions in the informal sector primarily include copper, brass, iron, aluminium, and all types of high-grade PCBs. There is no separation of different copper qualities. Several traders collect and store the fractions in a centralised collection area until a large quantity is reached. Large trucks and transport vehicles with access to the storage areas then transport the fractions to the formal sector, where they are traded for exports, with the exception of iron, which remains in the origin country. Leaching of PCBs to extract precious metals such as gold or platinum was not observed in Ghana's informal sector. PCBs are separated according to the type of device from which they originate. Collection of valuable fractions is efficient and has

Table 2
Risk matrix (5 × 5) used.

Likelihood/Impact	Negligible	Minor	Moderate	Significant	Severe
Very unlikely	1	2	3	4	5
Unlikely	2	4	6	8	10
Possible	3	6	9	12	15
Likely	4	8	12	16	20
Very likely	5	10	15	20	25

Table 3

Definition of used criteria for the risk assessment for each category based on considerable criteria for e-waste dismantling given in literature.

Risk criteria	Category	Definition of criteria	Literature source
C1 Revenue generated	Economic safety	Indicates the economic impact on the availability of devices containing valuable fractions as well as the factors influencing the buying and selling of products or fractions	(<i>Cucchiella et al., 2015; Mairizal et al., 2021; Streicher-Porte et al., 2005</i>)
C2 Market risk	Economic safety	Indicates the economic impact of buying e-waste on market conditions as well as general economic influences such as inflation risks, exports, and trading	(<i>Kumi et al., 2019; Shevchenko et al., 2019</i>)
C3 Disposal cost	Economic safety	Rating on expected disposal cost for fractions in case of formalisation	(<i>Davis and Garb, 2015; Prakash et al., 2010</i>)
C4 Ergonomic risk	Health safety	Ergonomic risk during dismantling process	(<i>Akormedi et al., 2013</i>) and based on own observations during field study on processes
C5 Accident risk	Health safety	Accident risk during dismantling process	(<i>Annamalai, 2015</i>) and based on own observations during field study on processes
C6 Environmental toxins	Health safety	Expected damage to health due to the release of environmental toxins	(<i>Amankwaa, 2013; Amankwaa et al., 2017; Heacock et al., 2016</i>)
C7 Water	Environmental safety	Process leads to the pollution of water bodies	(<i>Pradhan and Kumar, 2014; Wu et al., 2015</i>)
C8 Air	Environmental safety	Process leads to air pollution	(<i>Gangwar et al., 2019; Zeng et al., 2016</i>)
C9 Soil	Environmental safety	Process leads to soil pollution	(<i>Fujimori et al., 2016; Moeckel et al., 2020</i>)

a high value chain. Non-valuable fractions, and therefore materials of no interest to the informal sector, include (e-waste) plastics, foams, low-grade PCBs, and glass. Plastics from e-waste are usually not traded because there are no local or export markets available. Plastics, low-grade PCBs, and batteries are landfilled and likely burned subsequently for volume reduction. Glass and lead glass are used to backfill roads. This involves grinding the glass into fine dust, thereby facilitating environmental distribution and inhalation. Liquids (e.g., oil and ink) are spilt onto the ground, while other non-valuable parts, such as photoconductors, capacitors, light bulbs, cartridges, and toners, are landfilled.

Generally applied safety standards are not observed. In terms of safety equipment, gloves are worn, but protective goggles and shoes are not. The workers are unaware of the release of toxic substances. The risk

of electrical shock through capacitors from certain e-waste appliances is negligible, as the devices are separated from the power supply for at least 24 h and are hence not dismantled upon arrival at the scrapyards. Regarding the condition of the e-waste, spare parts are scavenged from 34% of the e-waste and sold to refurbishers. Spare printer and laptop parts are the most utilised. After they are scavenged, the device is completely dismantled to recover the valuable fractions. All assessed appliances are manually dismantled until further separation into pure materials is not possible without mechanical shredding.

3.2. Material flow analysis of processes

3.2.1. ICT devices dismantling

The dismantling of ICT devices follows a chain in which different workshops function as a trading system in a composition line comparable to that of a formal recycling company.

Fig. 3 shows the material flow for the desktop PC dismantling of one ton of input material. During the first step, the use of crude destructive techniques (e.g., using a hammer and chisel) is avoided to facilitate the removal of undamaged spare parts. Independent components are removed using screwdrivers and fine tools. Power boxes and drives are sold to the workshop that is next on the dismantling line for destruction. Other output fractions from the first dismantling process, such as motherboards, PCBs, and metals, are collected and traded at a later stage. Cables are burnt to extract copper.

After the first step, destructive disassembly techniques are used to dismantle the independent components to separate the fractions. The outcome fractions from this step are collected, traded, or channelled for burning or waste disposal. In the MFA for power box destruction, we

assumed that wiring contains 40% copper and that, by burning, 50% of the mass of transformers is lost. Approximately 10% of the input material from desktop-PC dismantling, mainly plastics, remains in the scrapyards or is later burned for waste volume reduction. Laptop and phone dismantling leads to over 60% of the input material remaining in the scrapyards.

Fig. 4 illustrates the flow of the laptop dismantling process. No batteries or screens attached to the laptops were found in the input, and separate copper collection was not observed. It was assumed that the copper attached PCBs is sorted into the PCB fraction to increase its weight. The screens and other wastes are included in the plastic fraction.

Fig. 5 shows the flow of the phone dismantling process. Batteries glued to the phone casing are sorted into plastic waste, which is landfilled and burned subsequently. Power cables and chargers from ICT devices do not undergo informal dismantling because they are removed before entering the scrapyards. ICT devices produce the highest share of (e-waste) plastic waste among the assessed processes. The plastic fraction is considered waste and is either landfilled or burned to reduce the volume.

3.2.2. CRT dismantling

Fig. 6 shows the material flow for informal CRT dismantling. Destructive methods are used to dismantle CRT devices, including opening and depressurising them using a hammer and chisel. The fractions of interest are the metallic parts of the tube, which contain copper, aluminium, iron, and other metals. PCBs in CRTs are of a low grade and are usually of no interest to the informal sector. Lead glass, plastic, and other waste fractions are dumped or burned. Glass bodies are frequently used to fill roads. The associated crushing of the fractions allows dust to

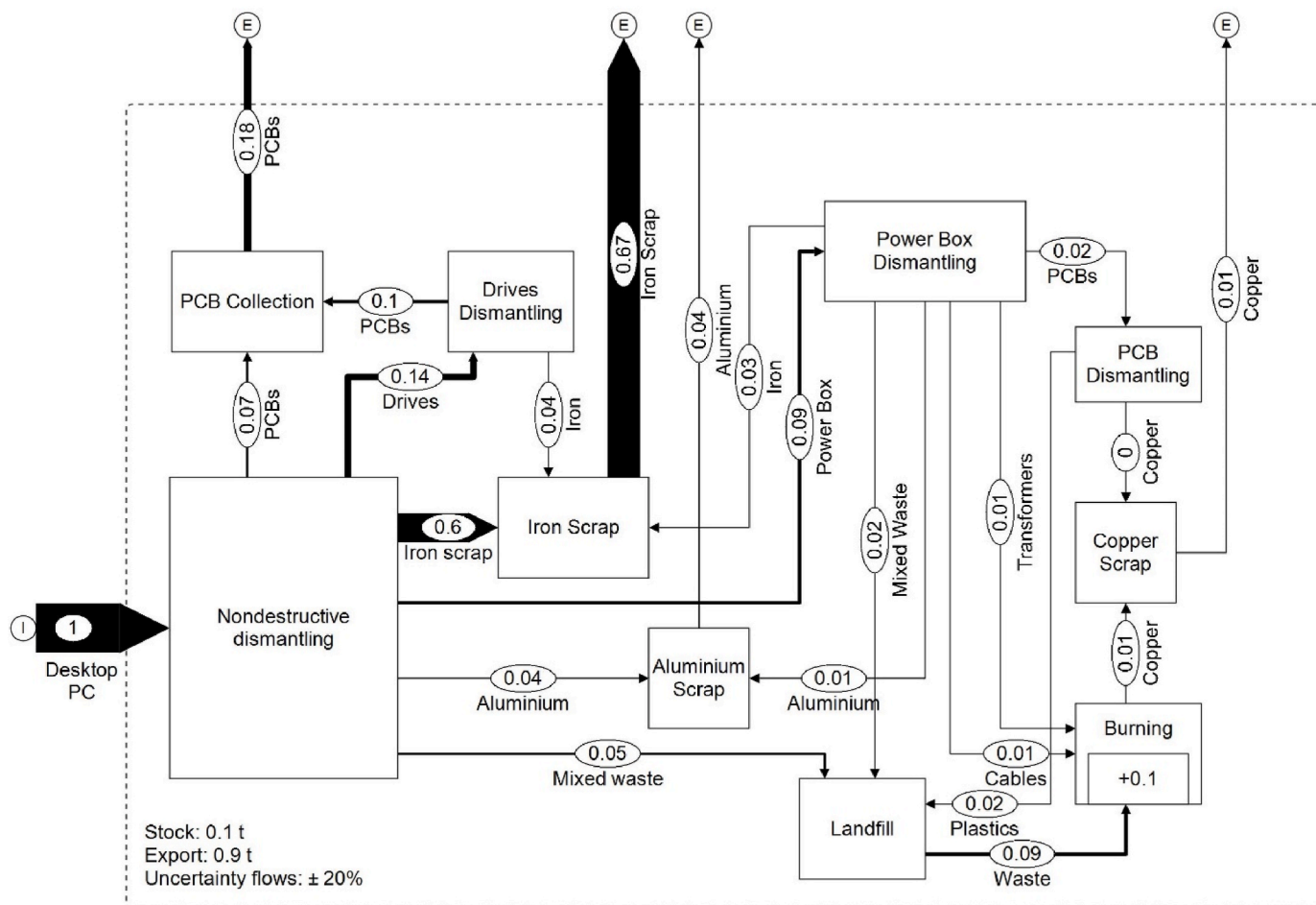

Fig. 3. Process flow in informal sector of desktop PC dismantling. Casing, power boxes and drives are dismantled in independently operating workshops.

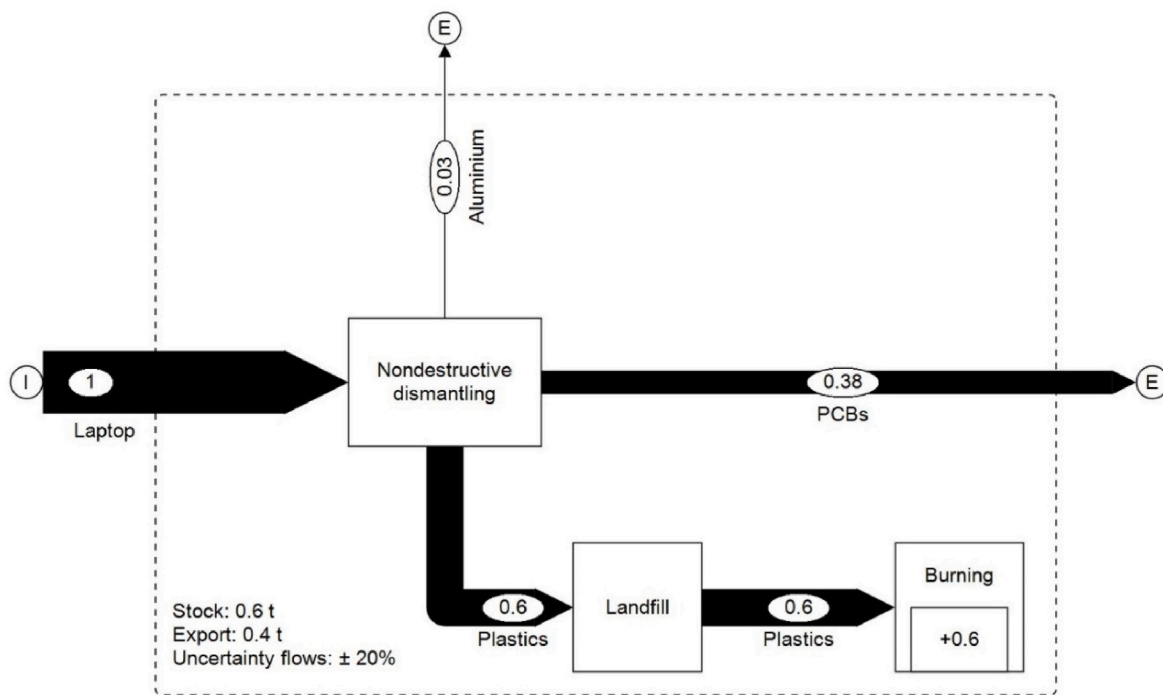

Fig. 4. Process flow of laptop dismantling in the informal sector.

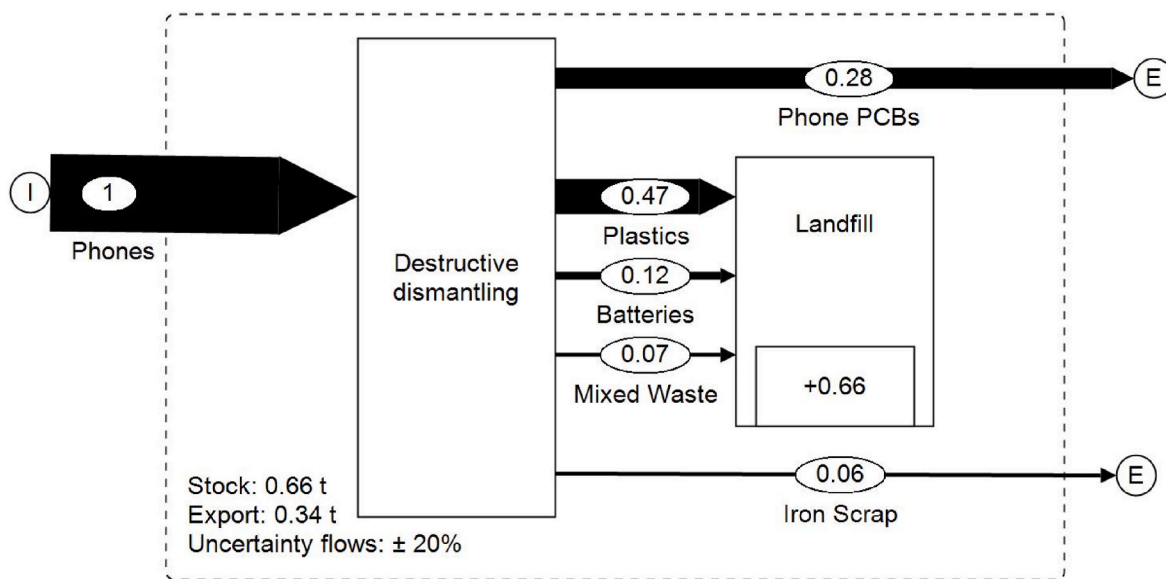

Fig. 5. Process flow of mobile phone dismantling in the informal sector.

disperse rapidly and enter the respiratory tract. Approximately 82% of the input fraction remains in the scrapyards. This is the highest share among all assessed processes.

3.2.3. Compressor dismantling

Compressors enter the scrapyards within a refrigerator/AC or as individual compressors originating from repair shops. Fig. 7 shows the material flow during dismantling. The main tools used for compressor dismantling are a hammer and chisel. The copper and aluminium parts are separated from the iron and plastics. Compressors contain small quantities of oil that spill onto the soil during dismantling. AC compressors contain more oil than refrigerator compressors, and their dismantling requires higher technical expertise. Only 1% (mainly oil) of

the input material in the process remains at the scrapyards. The remaining fractions are completely utilised.

3.2.4. Microwave dismantling

Non-destructive and destructive methods are combined to dismantle microwaves. The process flow is illustrated in Fig. 8. First, the microwave covers are unscrewed. Next, the transformer, bulb, plate, and cables are removed manually. The remaining microwave body is then added to the iron scrap. Capacitors are not removed and are, therefore, contained in the iron fraction. The transformer is dismantled using a hammer and chisel to remove copper. In the process flow shown, the quantities are too small to be displayed (1.5 kg per ton of microwaves recycled). The cables are collected for burning, and glass plates from the

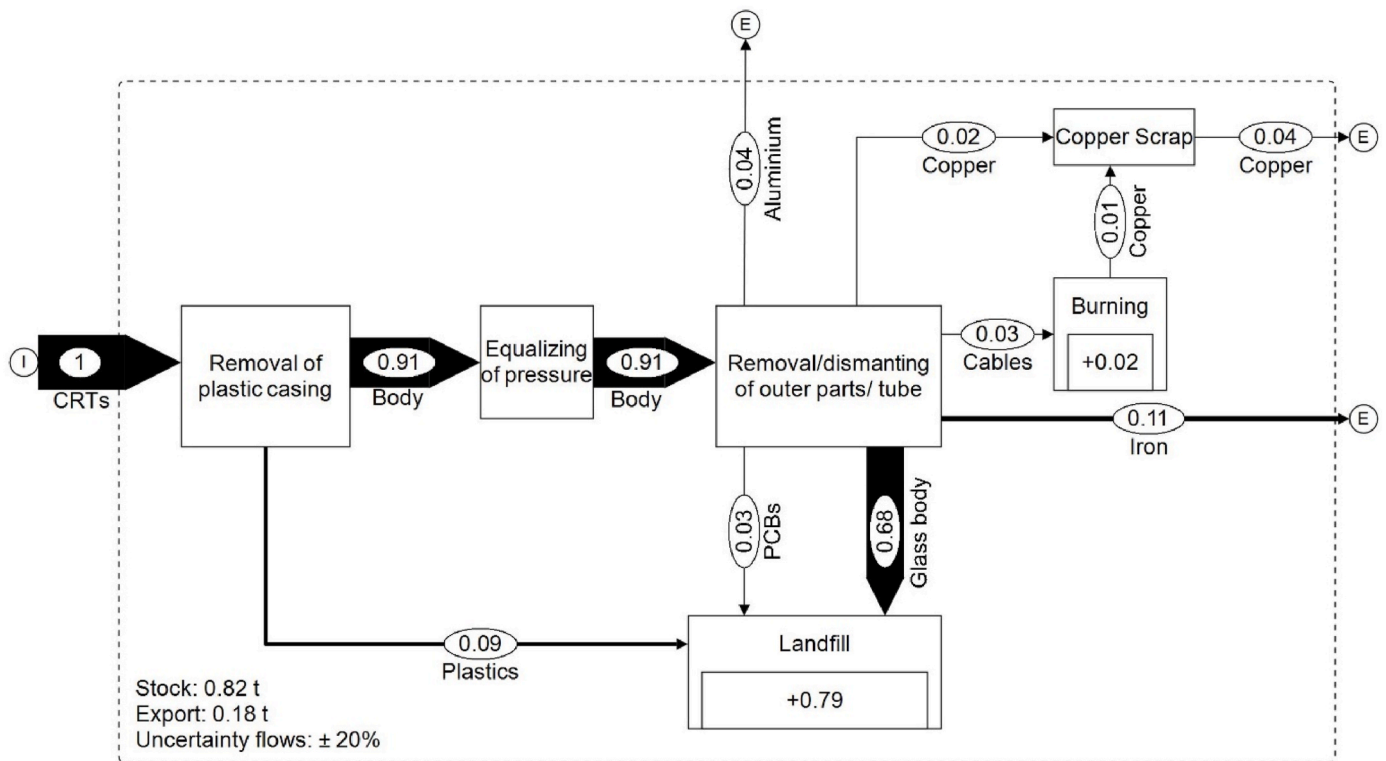

Fig. 6. Process flow of CRT dismantling in the informal sector.

microwaves are seldom contained in the devices when they arrive at the workshops. The microwaves are dismantled until no further manual dismantling is possible.

3.2.5. Printer dismantling

Printer dismantling at scrapyards is performed for home and large office printers. Cartridges and toners are dismantled at the same workshops where printers are dismantled and are illustrated together in the process flow diagram (Fig. 9) for the sake of simplicity. Hammers and screwdrivers are used to dismantle the printers. When a spare part is needed, the plastic casing is unscrewed; otherwise, the casing is removed by smashing it into pieces. Cartridges are removed, partially sold to second-hand users/recyclers or dismantled.

We assumed that toners and cartridges contain 10% ink material and that 42% of the toners are recoverable metals while the rest is plastic. Ink and toner powder are spilt during dismantling. Plastics are landfilled and partially burned to reduce their volume. Approximately 54% of the input material remains at the scrapyard.

3.3. Economic assessment

Recycling-related expenses comprise two main parts: the cost of purchasing e-waste, which is bought from households through door-to-door collection, and labour costs. Land use-, rental-, or operation-associated levy costs should also be considered in workshop operations. However, this was not considered in this study as most scrap yards are illegally located in public places and, therefore, do not incur rental costs. Labour costs in scrapyards depend on the dismantling process and time spent and are relatively high compared to Ghana's average income level. However, employment and payment are mostly on an hourly basis, and workers only generate an income when work is available. Therefore, the income of workers is considered unstable. The time required to dismantle a device and the device's weight were measured to calculate the labour cost per kilogram. To protect the privacy of the survey respondents, who were asked sensitive questions regarding their

economic situation, they were assured that the raw data would be kept confidential. Consequently, specific details such as labour costs, e-waste prices, and device weights are intentionally withheld to prevent the possibility of tracing them back to the individuals.

Metal prices at the scrapyard are usually calculated per pound of weight; kilograms were used in this study. Except for iron, prices fluctuate with world market prices. Local iron prices exceed the world market price because iron is smelted or further processed in Ghana, eliminating the cost of importing and shipping foreign iron. Copper and brass are exported exclusively because Ghana has no processing facilities. For exported metals, prices are below world market prices because the exporting cost should be factored in. Aluminium is partly exported, and that retained in Ghana is used for local production, such as sand casting for cooking pots. Phone PCBs had the highest price per kilogram of weight.

Fig. 10 shows the expenses associated with the informal recycling of each assessed type of device and the composition of the profits. Most of the profits are generated from PCBs and copper.

Most of the e-waste were between 10 and 20 years old before reaching the end-of-life dismantling stage (Fig. 11). Old devices are preferred for dismantling because they often contain more copper, the most sought-after metal in the informal chain. The informal sector is well aware that newer e-waste contains fewer valuable materials and more plastics. However, owing to economic needs, newer types are also dismantled. The most popular devices to dismantle are ACs and fridges with iron casings because of the relatively high metal content, especially copper, in ACs, as well as phones because of their high-priced PCBs. The popularity of a device generally depends on its brand, origin, and age. The interviews with the participants revealed that older phones are popular in terms of revenue because they are heavier and contain more nonferrous metals, such as copper and brass. Because older models are no longer in production, their fractions will become scarcer and perhaps more valuable in the future. This is also evident for computers and laptops. The number of available CRT monitors for dismantling is decreasing; however, they are also a popular waste fraction because of

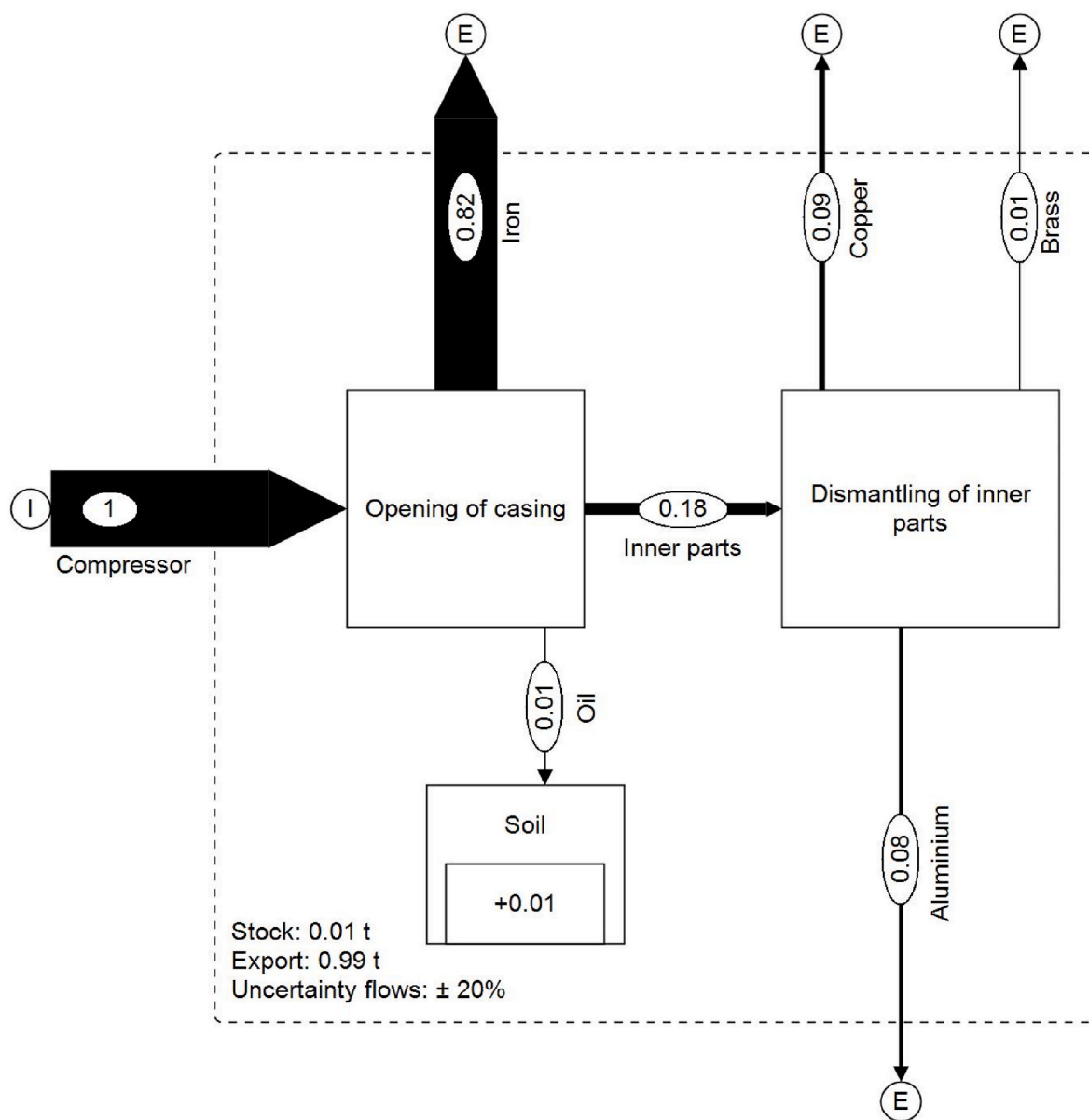

Fig. 7. Process flow of compressor dismantling in the informal sector.

their high copper content. This illustrates how the informal sector may face economic problems within a few years.

3.4. Risk assessment

The risk assessment was conducted for all processes and the results are shown in Fig. 12. Most environmental and health threats occur because of secondary treatment methods (e.g., burning of plastics) for non-valuable fractions in the informal sector. The risk to environmental safety is considered moderate for processes 1 and 4, high for 2 and 3 and severe for process 5. Process 5 has a higher outcome due to the release of inks into the soil that contributes to pollution of water bodies and high plastic waste accumulation, which is likely to be burned. Crude methods, such as manual dismantling, do largely contribute to environmental pollution as long as all fractions are collected and stored. However, destructive dismantling can damage hazardous components and release pollutants, such as ink and oil, into the environment. This risk was not present in processes 1 and 4.

Health risks are in relationship with environmental risks and mainly occur due to a lack of safety equipment and the release and uptake of

pollutants. Health risks are given in all the assessed processes. A process with severe risks is process 2, due to the risk of implosion of the CRT during dismantling. Destructive methods can lead to particles and pollutants dispersing (e.g., through the crushing of protective phone covers) which can then lead to eye injuries or inhalation of pollutants. Cuts from sharp components also pose a high risk. Non-destructive dismantling where fine tools are used, as practised in Process 1, poses the smallest health risk.

All processes present a considerable economic risk. Significant economic challenges are expected for processes where most of the revenue is generated through copper (Processes 2–4), because newer EEE often does not contain solid copper wire but aluminium-coated copper wires. Once this device dominates end-of-life processing, the processes will not be able to generate sufficient revenue to sustain themselves. CRT devices are becoming increasingly less common because they are no longer produced. Modern EEE are smaller and lighter than old devices and are built in a cost- and resource-efficient manner. The effect of the lowered copper content in devices was identified as a major upcoming economic barrier.

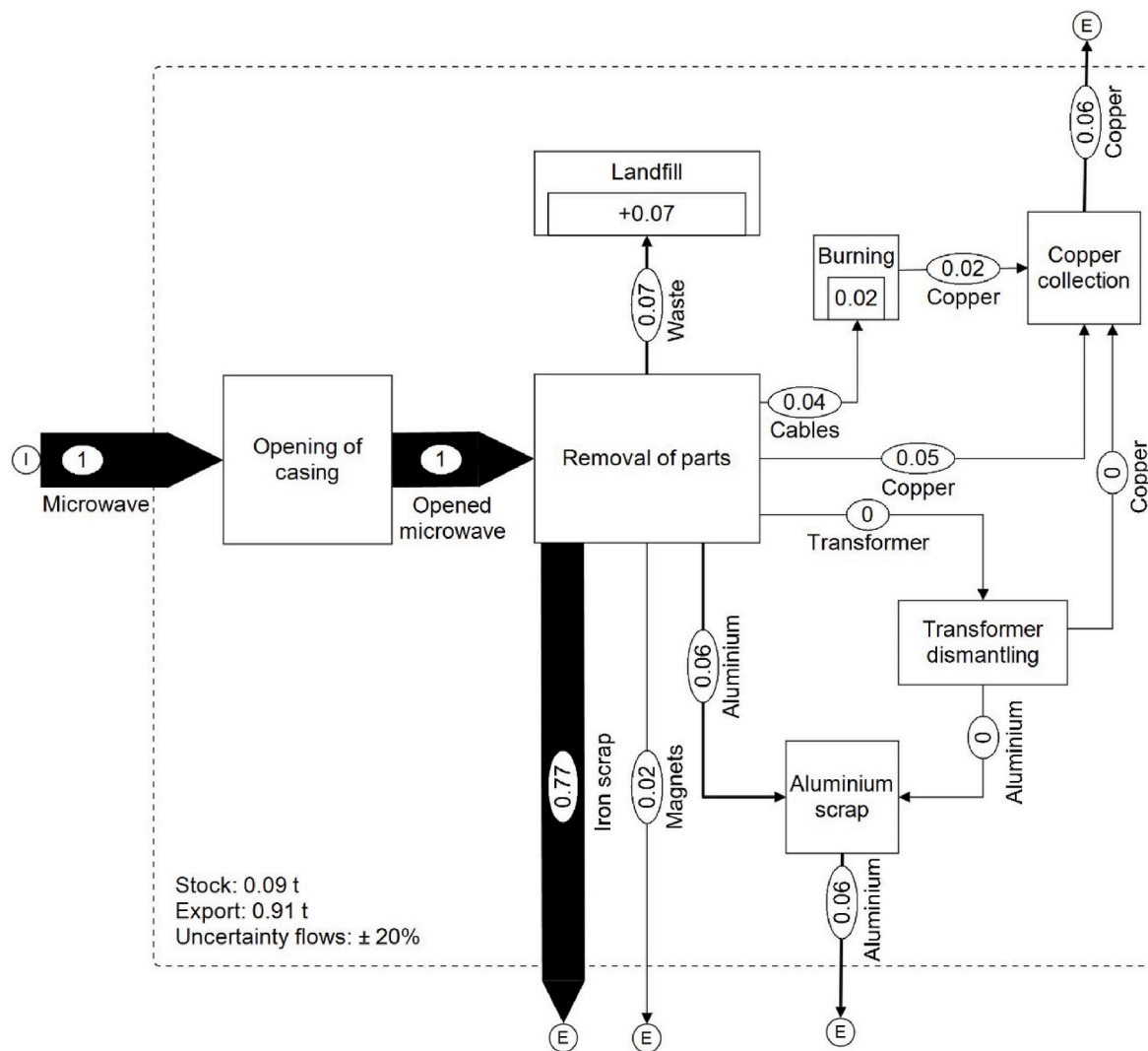

Fig. 8. Process flow of microwave dismantling in the informal sector.

4. Discussion

Herein, we used a methodological approach which combined qualitative and quantitative data assessment. The assessment and methodology allowed us to understand the processes and their impacts on the environment, economy, and health safety.

4.1. Material flow analysis of processes

Our assessment revealed the methods used by the informal sector in Ghana to dismantle e-waste and points out which fractions are produced during the process. Hence, it was confirmed that the informal sector in Ghana is well-organised, connected, and structured. Also, they are well-trained on how to retrieve the most valuable fractions within a short period of time. The e-waste is dismantled manually to a point where no further manual dismantling is possible, and the valuable materials are well sorted. The effectiveness of the informal sector has thus been confirmed. Nevertheless, the material flow analysis of the processes also highlighted the associated problems with local e-waste recycling. These lie primarily in the further treatment of waste fractions that arise. They have been identified and this data can now be used for organisational and structural planning.

Table 4 lists the emerging fractions predicted from the assessment processes. Specific fractions, such as batteries (laptops, phones), screens,

glass, light bulbs, and cartridges, rarely appear in dismantling workshops. Power cables and plugs were not usually attached to the devices anymore. These fractions are eliminated upstream during informal collection, where they are sold (e.g., cables and plugs) to generate extra income, or others, because of their lack of value, are removed and littered to reduce weight during transportation. In order to adapt the system in an environmentally sound way, the remaining fractions must be known and investigated.

The remains from informal recycling are landfilled or burned. Summing up all assessed processes, a share of 40.3% of emerging fractions arising in all assessed processes, are landfilled or burned. Whereof the processing of ICT appliances (desktop PC, laptops and phones) (P1) contributes with 19.4%, CRT appliances (P2) with 11.7%, compressors from cooling appliances (P3) with 0.1%, microwaves (P4) with 1.3% and printers (P5) with 7.7 % to the landfilled or burned fractions.

From laptop dismantling in process 1 plastic is landfilled with a share of 60% within this process. A major concern is that their batteries and partly screens do not reach informal scrapyards oftentimes. More research is needed in the remain of those fractions. Phone dismantling in process 1 contributes with 47% of plastics, 12 % of batteries and 7% of mixed waste such as screens and keyboards to the landfilling. Plastics and batteries landfilled from all processes are to a large part and frequently burned for waste reduction purposes. CRT monitors are the process with largest share of landfilled fractions. 82% of a CRT monitor

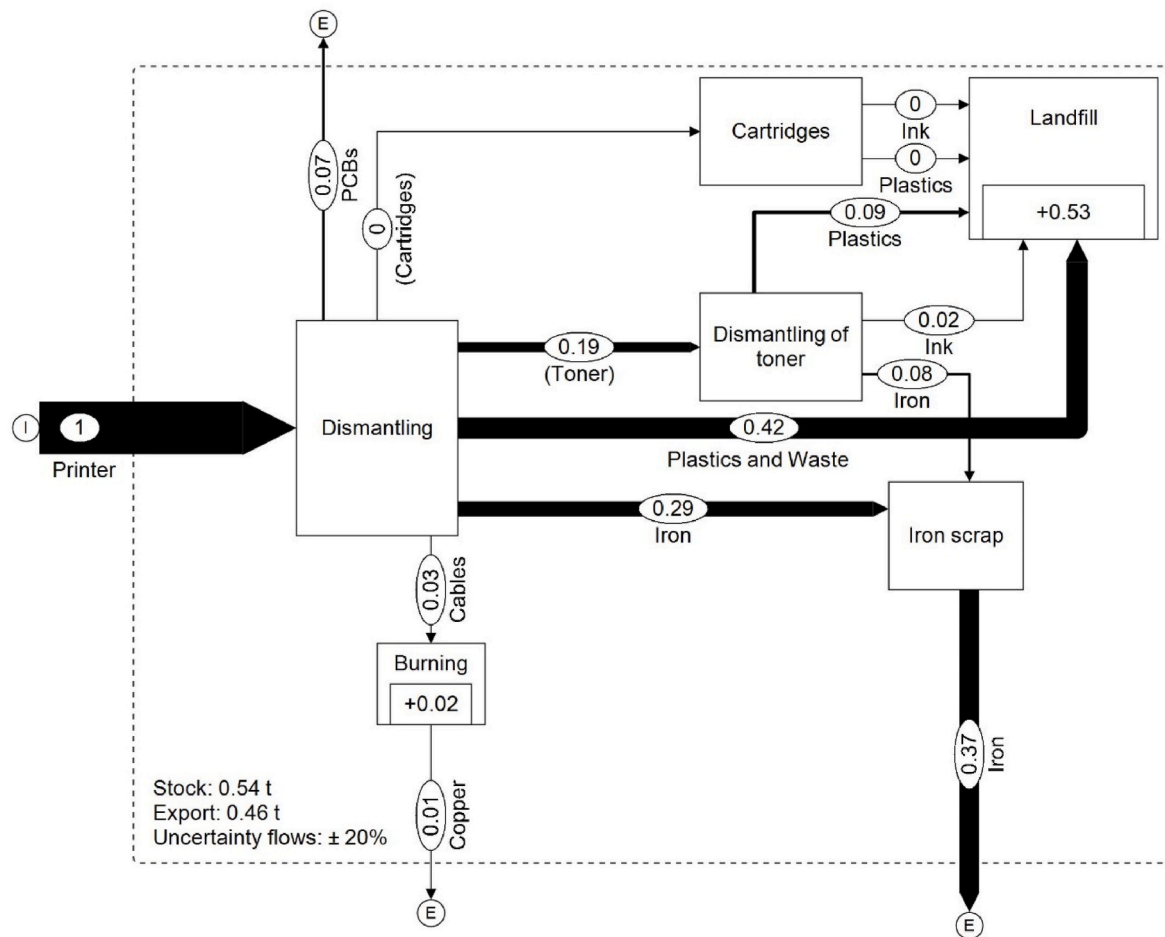

Fig. 9. Process flow of printer dismantling in the informal sector.

is dumped. This fraction largely consists of glass and lead glass with a share of plastics and low grade PCBs. Within process 5, 53% of the printer is landfilled, mostly consisting of plastics but also ink and other wastes such as bulbs from printers. Process 3 (compressor dismantling) plays a particular role here, as it contributes mass wise little to landfilling, but the release of coolant-contaminated oil has been assessed as a major risk to the environment and groundwater which leads to a higher ranking at the risk assessment.

Formal or registered companies buy and manage valuable fractions produced by the informal sector, take care of transportation, and exports to downstream markets or processing. Current infrastructure, i.e., centralised and good accessible collection points and transport systems for valuable and hazardous fractions in informally operated scrapyards, are needed as a form of integration. Sustainable incentive systems must be created to collect material flows appropriately. Since the informal sector is mostly organised by associations, they can be approached to plan and set up a mandatory collection point or system.

4.2. Economic assessment

The informal sector primarily incurs labour costs for dismantling e-waste and the purchase price of e-waste from households or intermediaries involved in informal collection. Among the various processes, ICT dismantling has the highest profit margin, whereas printers exhibit the lowest profit margin, at a mere 16%.

Copper and PCBs are the primary sources of income in the informal sector. Recycled e-waste is most commonly 10–20 years old. Technological development and the production of smaller devices with less resource input and intrinsic material value suggest that the amount of

copper and precious metal content in PCBs will decrease over time. Simultaneously, the plastic content of appliances increases. Consequently, the economic impact on this sector will be significant when current-generation devices reach end-of-life processing. We project that this scenario will occur within approximately 10–20 years. This study shows concerns that the informal sector may no longer be equipped to handle the reverse supply chain effectively at that point. Devices could be no longer disassembled manually because economic viability. This could lead to reduced separation and increased landfilling and burning of more waste.

The economic value of potentially recyclable fractions but currently landfilled fractions such as plastics is much lower than the economic value of metals and PCBs in e-waste. It is assumed that the informal e-waste sector in particular does not focus on the landfilled fractions due to economic viability although some of the fraction have a local downstream market in Ghana. In the search for valuable materials in household waste, on the other hand, the informal sector also collects market plastics and glass for the local downstream processing (Miezah et al., 2015; Oduro-Appiah et al., 2017). This means that there is a local market for currently landfilled or burned fractions, naming PET plastics, PP Plastics, LDPE and HDPE plastics and glass (Oduro-Kwarteng et al., 2016). Therefore, we recommend to link and implement organisational measures and plan a collection centre locally at the informal small enterprises as well as a joint downstream management.

4.3. Risk assessment

The risk assessment showed that there are considerable risks in environmental, economic and health safety for all processes. In terms of

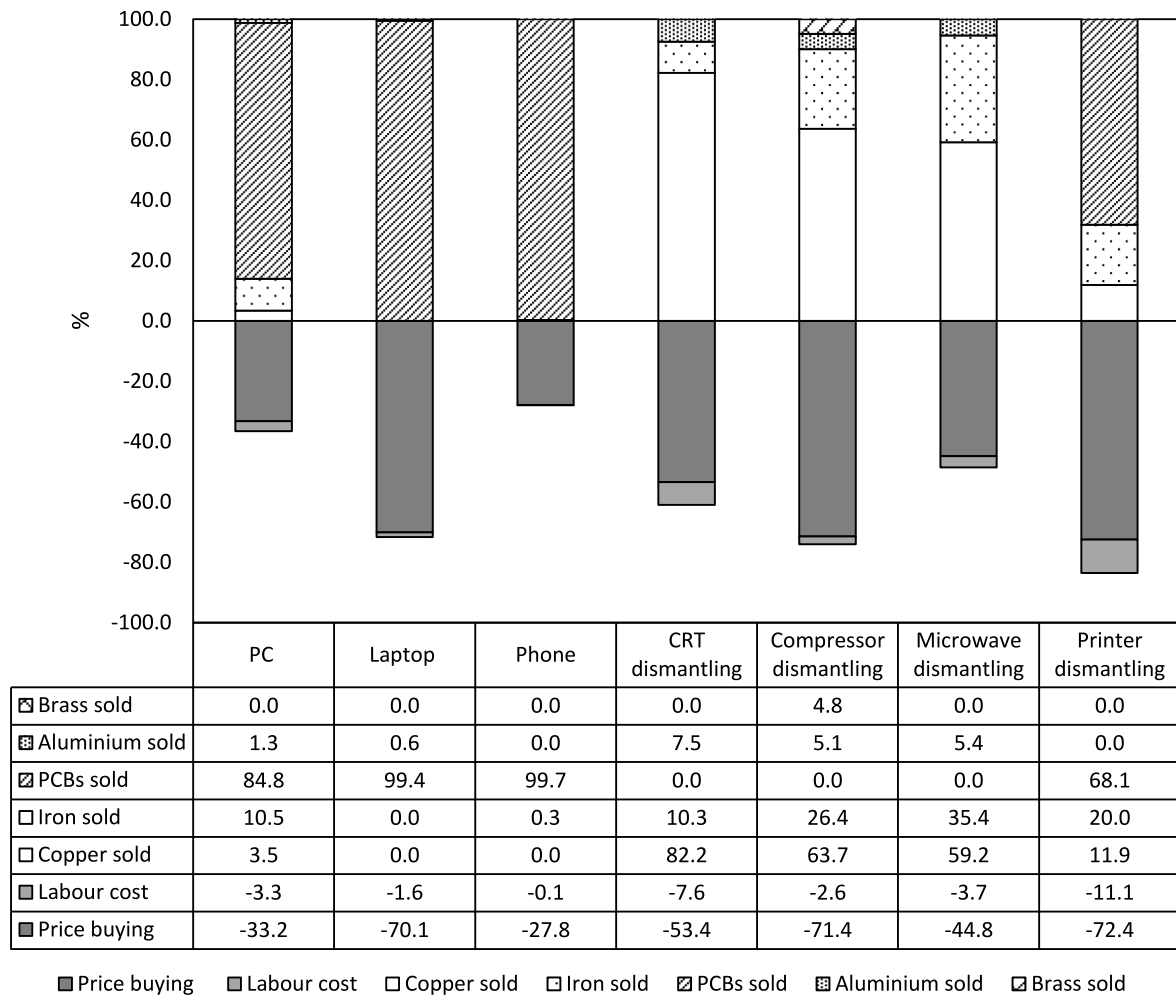

Fig. 10. Economic assessment of each device group with percent share of total revenue and expenditures.

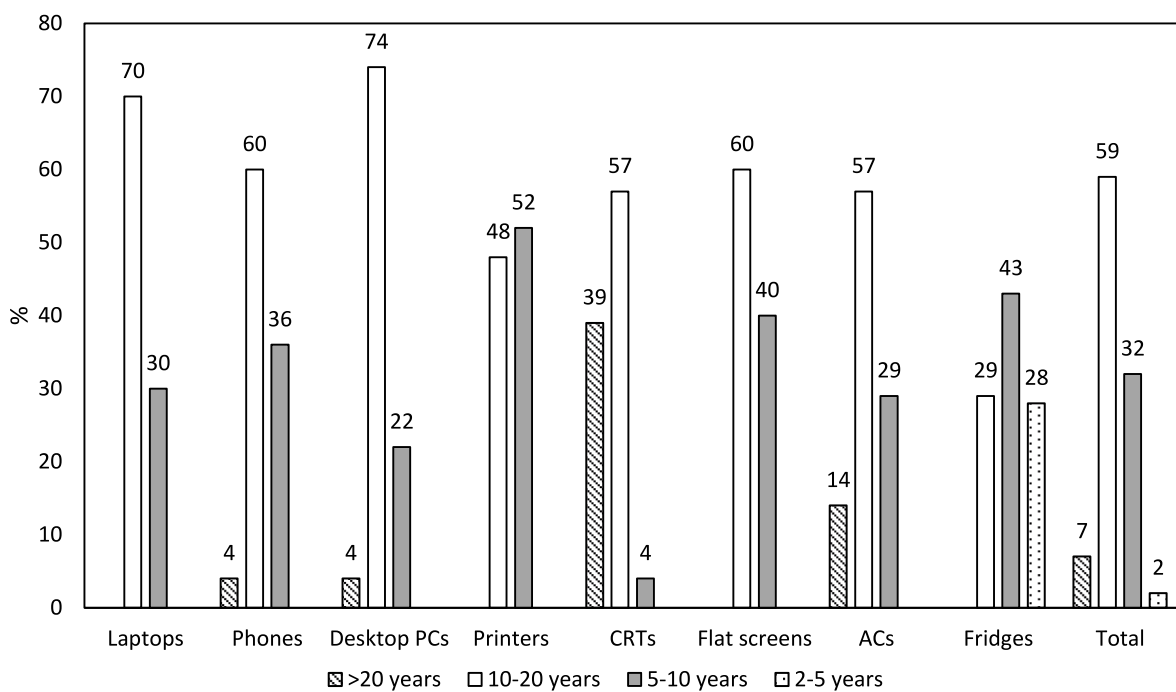

Fig. 11. Age distribution of e-waste types dismantled in the informal sector in Ghana.

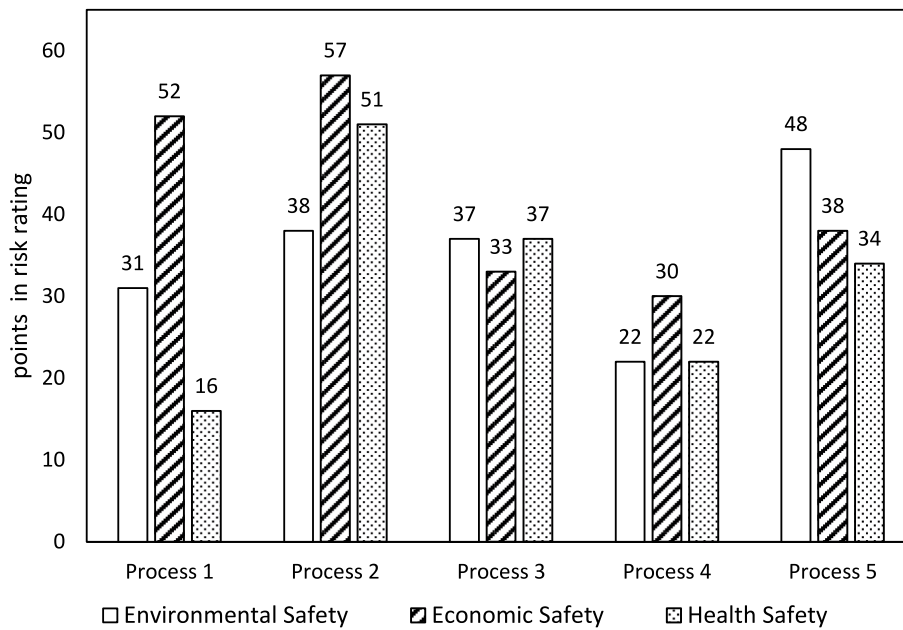

Fig. 12. Results of environmental, economic, and health safety risk assessment for processes 1-5.

Table 4

Matrix showing the expected accruing non-valuable fractions for each process according to our assessment. Fractions which were not found at the informal dismantling workshops are marked with brackets (x).

	F1	F2	F3	F4	F5	F6	F7	F8	F9	F10	F11	F12
P1	(x)	x	x	x	(x)				x			
P2		x	x			x	x		x			
P3												
P4		x	x	x			(x)	(x)	x			
P5		x	x	x					x	x	(x)	x
P1	Desktop-PC, Notebook-PC and mobile phone dismantling											
P2	CRT-monitor and -TV dismantling											
P3	Fridge/AC Compressor dismantling											
P4	Microwave dismantling											
P5	Printer dismantling											
F1	Batteries											
F2	Plastics with flame retardants											
F3	Plastics without flame retardants											
F4	Capacitors >25 mm											
F5	Screens form notebook											
F6	CRT glass											
F7	Glass											
F8	Light bulbs											
F9	Low-grade PCBs											
F10	Photo conductor unit											
F11	Cartridges											
F12	Toners											

economic risk Processes 1 and 2 in particular stand out. For process 1 the technology development, showing in lighter weight and lower intrinsic material value of future e-waste items play a role. The economic risk in process 2 is based on the fact that CRTs are currently not produced anymore and therefore the informal shops only handling CRTs will face economical risks. For the environmental safety, process 5 shows the highest risks due to the pollution of soil, groundwater and air by the emerging fractions.

To address all risks, the processes need to find improvement under the following order of priority for action P2>P5>P3>P1>P4. If only the environmental risk is to be taken into account, the range is from the most urgent need for action to the lowest is P5>P2>P3>P1>P4. On the basis of the risk assessment it could be determined that there is an urgent need for action, especially the processes 2 and 5.

4.4. Barriers for sustainable e-waste management

The informal e-waste sector plays a vital role in Ghana, addressing an ongoing issue where public and formal sector involvement is limited. The integration of the informal recycling sector brings about numerous advantages, encompassing environmental, economic and social benefits. It contributes to income generation for individuals with lower economic means, less release of pollutants and the conservation of natural resources, serving as a significant driver of sustainable change in the country.

In the process of integrating the informal sector, several challenges and opportunities have been identified. One significant obstacle is the limited access of the informal e-waste sector to the existing formal and informal waste collection infrastructure, particularly for specific waste fractions. To address this, structured management of distinct waste

categories is crucial.

Our research findings shed light on the unaccounted waste fractions that have the most pronounced environmental and health impacts. Notably, emerging market plastics and glass from e-waste recycling offer substantial potential for integration. These fractions can be effectively connected with both the informal household waste picking system and the established formal plastic and glass recycling companies in Ghana. Additionally, the collection of emerging oil can be coordinated with local waste-oil collection enterprises.

On the other side, the lack of collection and downstream treatment of potentially hazardous, cost-intensive, and non-market waste fractions, such as brominated plastics, batteries, and lead glass, poses another barrier to informal sector integration. To address this challenge, it is essential to integrate the informal e-waste sector into a controlled collection processes for these specific waste fractions. This integration process calls for the establishment and oversight of central collection points for the identified waste fractions through a public organisational structure. Downstream processing for these fractions should be entrusted to political stakeholders and decision makers. Addressing landfill-bound fractions, especially those without established markets, requires the implementation of a binding collection framework, meticulous planning and provisioning of collection logistics, declaration of safety measures for health protection, and the provision and management of suitable containers with accessible features, representing initial steps toward achieving sustainable waste management.

4.5. Data quality, limitations and placement in the overall context of developing countries

The accuracy of the MFA was rated to $\pm 20\%$ according to the researchers' estimation of data accuracy (Laner et al., 2014). The reason therefore is that the assessed datasets must be viewed within the framework of the informal sector, meaning that building trust, rapport with participants, collaboration with local associations, and the careful navigation for the ethical and regulatory landscape was considered as essential for this research. However, this is also a limiting factor as for data collection the researchers are reliant on the cooperation of the informal sector. The influence of market changes, inflation and seasonal characteristics, such as rainy season, are also seen as other limiting factors. The organisational structure of an informal system is also a limiting factor, as some informal scrapyards have geographical particularities such as proximity to water bodies, space limitation or a location with no landfill enclosed. Hence, landfilling or burning process take place at other areas. This needs to be considered when implementing measures.

Within Ghana, the structures and processes of the informal e-waste recyclers and scrapyard structures are similar, so that comparisons and conclusions among them can be drawn. For informal e-waste treatment outside of Ghana in the context of other developing countries, this must be assessed on a case-by-case basis.

4.6. Areas for future investigation

Further research should focus on several key areas. Firstly, there is a need to investigate the fractions that have the potential to be hazardous but are not currently reaching informal sector dismantling, including screens, light bulbs, glass, laptop batteries, and cartridges (as shown in Table 2). Methods for targeting and collecting these fractions should be explored. Additionally, research should aim to identify local downstream processing and recycling options for the hazardous fractions. This involves finding sustainable and safe ways to manage these fractions after collection. There is a requirement to conduct targeted laboratory assessments of pollutants to better understand the actual environmental impact and risk associated with the recycling processes. This research will contribute to a more comprehensive assessment of the environmental and health implications of informal e-waste recycling.

5. Conclusions and recommendations

In this study we applied a multimethod approach to assess the mass and material flows of relevant informal e-waste dismantling processes and evaluated the risks and fields of action for the environment, economy, and health safety.

The assessment of the informal e-waste sector has offered valuable insights into the processes of e-waste dismantling, contributing essential information for the management of the informal sector in the pursuit of establishing a sustainable e-waste recycling system in Ghana. It has been verified that the informal sector excels in skilled manual dismantling and the efficient retrieval and sorting of valuable fractions. However, the informal sector's shortcomings are evident in practices like landfilling, uncontrolled burning of waste fractions, cable burning for metal retrieval, and a lack of safety equipment usage.

Our research showed that initial manual dismantling does not have a significant impact on environmental pollution. The health risks in this stage primarily arise from the absence of safety and protective attire. The main environmental and health risks primarily stem from the secondary treatment of non-valuable fractions within the sector. These practices involve activities such as burning plastics to reduce waste, landfilling of liquids and other residues, and the burning of copper cables using foams as a fuel. It's important to note that many of these secondary treated fractions have the potential for recycling but currently lack access to collection and downstream markets. These fractions encompass plastics, e-waste plastics, cartridges, toners, oil, glass, lead glass, and low-grade PCBs. Addressing the processes that result in fractions being sent to landfills or subjected to secondary treatment is a significant challenge. In total, 40.3% of emerging fractions from all assessed processes end up in landfills or are burned.

The risk assessment showed that there are considerable risks in environmental, economic and health safety for all processes. Under the overall risk assessment of all categories for the processes, the processes have the following order of priority for action $P2 > P5 > P3 > P1 > P4$. If only the environmental risk is to be taken into account, the range is from the most urgent need for action to the lowest is $P5 > P2 > P3 > P1 > P4$.

The primary economic incentive for informal e-waste dismantling lies in the recovery of copper and PCBs. Other metals have a secondary role due to their lower value compared to these key fractions. They are regarded as supplementary rather than central drivers. Labour costs for e-waste dismantling and the purchasing price of e-waste from households or intermediaries engaged in informal collection are the primary financial burdens on the informal sector. Among the various processes, ICT dismantling has the highest profit margin, whereas printers exhibit the lowest profit margin, at a mere 16%. Furthermore, it is essential to anticipate a significant economic challenge for the informal sector in the next 10–20 years, originating from the diminishing intrinsic material value of e-waste resulting from ongoing technological advancements.

As highlighted previously, the economic value of potentially recyclable fractions, like market plastics, falls considerably below that of the key fractions. There's a presumption that the informal e-waste sector, in particular, does not prioritize the collection of these less valuable fractions. Consequently, we propose establishing organizational measures to connect both sectors and plan for a local collection centre situated at the informal small enterprises. Additionally, a collaborative downstream management approach should be considered.

According to our comprehension and based on our research findings, the presence of the informal e-waste sector in Ghana is essential at this point. This can be attributed to the lack of financial resources in the political sphere, the absence of infrastructure for formal e-waste recycling options, the sector's high efficiency and its substantial impact on poverty reduction, especially within the most economically underprivileged population groups. Nevertheless, there is a clear need for specific measures to promote more sustainable management through the integration of the informal sector, tailored to its unique requirements.

The MFA and risk assessment have highlighted the necessity of

prioritizing processes with significant proportions of landfilled fractions to mitigate potential environmental risks. In this context, the primary manual dismantling for most processes could remain within the informal sector, provided certain conditions are met. However, for Process 2 (CRT dismantling), we recommend transferring this responsibility away from the informal sector due to the substantial risk of implosion during dismantling and the associated risks identified in the risk assessment. Additionally, it is essential to avoid the burning of cables and instead focus on their collection. This transition necessitates the creation of alternative income opportunities for the group commonly referred to as “burners.”

As for the remaining processes, we suggest an approach that involves integrating them by permitting manual dismantling through the informal sector. This should be accompanied by the establishment of a binding system for collecting emerging hazardous fractions, cables and market fractions that have not been previously collected.

Data statement

Due to the sensitive nature of the questions asked in this study, survey respondents were assured that the raw data would remain confidential and not be shared.

CRedit authorship contribution statement

Karoline Owusu-Sekyere: Methodology, Software, Validation, Formal analysis, Conceptualization, Data curation, Visualization, Writing – original draft, Writing – review & editing. **David Alatule Aladago:** Data curation, Validation.

Declaration of competing interest

The authors declare that they have no known competing financial interests or personal relationships that could have appeared to influence the work reported in this paper.

Data availability

The data that has been used is confidential.

Acknowledgements

This research was supported by the GIZ Project “Environmentally Sound Disposal and Recycling of E-waste in Ghana”, funded by the German Federal Ministry for Economic Cooperation and Development (BMZ). We thank our colleagues from the GIZ E-Waste project, who provided insight and expertise that greatly assisted the research.

This work was also supported by funding through the Hans Boeckler Foundation (Funding No. 407867).

Appendix A. Supplementary data

Supplementary data to this article can be found online at <https://doi.org/10.1016/j.jclepro.2023.139706>.

References

- Achillas, C., Aidonis, D., Vlachokostas, C., Karagiannidis, A., Moussiopoulos, N., Loulos, V., 2013. Depth of manual dismantling analysis: a cost-benefit approach. *Waste Manag.* 33, 948–956. <https://doi.org/10.1016/j.wasman.2012.12.024>.
- Adanu, S.K., Gbedemah, S.F., Attah, M.K., 2020. Challenges of adopting sustainable technologies in e-waste management at Agbogbloshie, Ghana. *Heliyon* 6. <https://doi.org/10.1016/j.heliyon.2020.e04548>.
- Akormedi, M., Asampong, E., Fobil, J.N., 2013. Working conditions and environmental exposures among electronic waste workers in Ghana. *Int. J. Occup. Environ. Health* 19, 278–286. <https://doi.org/10.1179/2049396713Y.0000000034>.
- Amankwaa, E.F., 2014. E-Waste livelihoods, environment and health risks. *Unpacking the Connections in Ghana* 22, 1–15.
- Amankwaa, E.F., 2013. Livelihoods in risk: exploring health and environmental implications of e-waste recycling as a livelihood strategy in Ghana. *J. Mod. Afr. Stud.* 51, 551–575. <https://doi.org/10.1017/S0022278X1300058X>.
- Amankwaa, E.F., Adovor Tsikudo, K.A., Bowman, J., 2017. ‘Away’ is a place: the impact of electronic waste recycling on blood lead levels in Ghana. *Sci. Total Environ.* 601–602, 1566–1574. <https://doi.org/10.1016/j.scitotenv.2017.05.283>.
- Amoyaw-Osei, Y., Agyekum, O.O., Pwamang, J.A., Mueller, E., Fasko, R., Schluep, M., 2011. *Ghana E-Waste Country Assessment*. SBC e-waste Africa Project.
- Annamalai, J., 2015. Occupational health hazards related to informal recycling of E-waste in India: an overview. *Indian J. Occup. Environ. Med.* <https://doi.org/10.4103/0019-5278.157013>.
- Asante, K.A., Amoyaw-Osei, Y., Agusa, T., 2019. E-waste recycling in Africa: risks and opportunities. *Curr. Opin. Green Sustainable Chem.* 18, 109–117. <https://doi.org/10.1016/j.cogsc.2019.04.001>.
- Asibey, M.O., Lykke, A.M., King, R.S., 2022. Understanding the factors for increased informal electronic waste recycling in Kumasi, Ghana. *Int. J. Environ. Health Res.* 32, 305–320. <https://doi.org/10.1080/09603123.2020.1755016>.
- Baldé, C.P., Angelo, E.D., Luda, V., Deubzer, O., Kuehr, R., 2022. *Global Transboundary E-Waste Flows Monitor 2022* 66.
- Brunner, P.H., Rechberger, H., 2004. *Practical Handbook of Material Flow Analysis*. Lewis Publishers.
- Chen, D., Faibil, D., Agyemang, M., 2020. Evaluating critical barriers and pathways to implementation of e-waste formalization management systems in Ghana: a hybrid BWM and fuzzy TOPSIS approach. *Environ. Sci. Pollut. Res.* <https://doi.org/10.1007/s11356-020-10360-8>.
- Creswell, J.W., Creswell, J.D., 2017. *Research Design: Qualitative, Quantitative, and Mixed Methods Approaches*. Sage Publ. <https://doi.org/10.4324/9780203803448-9>, 15–30.
- Cucchiella, F., D’Adamo, I., Lenny Koh, S.C., Rosa, P., 2015. Recycling of WEEE: an economic assessment of present and future e-waste streams. *Renew. Sustain. Energy Rev.* 51, 263–272. <https://doi.org/10.1016/j.rser.2015.06.010>.
- Daum, K., Stoler, J., Grant, R.J., 2017. Toward a more sustainable trajectory for e-waste policy: a review of a decade of e-waste research in Accra, Ghana. *Int. J. Environ. Res. Publ. Health* 14. <https://doi.org/10.3390/ijerph14020135>.
- Davis, J.M., Garb, Y., 2015. A model for partnering with the informal e-waste industry: rationale, principles and a case study. *Resour. Conserv. Recycl.* 105, 73–83. <https://doi.org/10.1016/j.resconrec.2015.08.001>.
- DeWalt, Kathleen Musante DeWalt, B.R., 2010. *Participant Observation: A Guide for Fieldworkers*, second ed. Rowman Altamira.
- Dhillon, J., Sandhu, V., 2017. Integrating the activities of informal and formal sector in E-waste management: potential benefits and challenges. *Int. J. Latest Technol. Eng. VI* 133–136.
- Dumay, J., Hossain, M.A., 2019. Sustainability risk disclosure practices of listed companies in Australia. *Aust. Account. Rev.* 29, 343–359. <https://doi.org/10.1111/auar.12240>.
- Duygan, M., Meylan, G., 2015. Strategic management of WEEE in Switzerland - combining material flow analysis with structural analysis. *Resour. Conserv. Recycl.* 103, 98–109. <https://doi.org/10.1016/j.resconrec.2015.06.005>.
- Forti, V., Baldé, C.P., Kuehr, R., Bel, G., 2020. *The Global E-Waste Monitor 2020: Quantities, Flows and the Circular Economy Potential*. United Nations University (UNU)/United Nations Institute for Training and Research (UNITAR) – co-hosted SCYCLE Programme, International Telecommunication Union (ITU) & International Solid Waste Association (ISWA), Bonn/Geneva/Rotterdam.
- Fujimori, T., Itai, T., Goto, A., Asante, K., Otsuka, M., Takahashi, S., Tanabe, S., 2016. Interplay of metals and bromine with dioxin-related compounds concentrated in e-waste open burning soil from Agbogbloshie in Accra, Ghana. *Environ. Pollut.* 209, 155–163. <https://doi.org/10.1016/j.envpol.2015.11.031>.
- Gangwar, C., Choudhari, R., Chauhan, A., Kumar, A., Singh, A., Tripathi, A., 2019. Assessment of air pollution caused by illegal e-waste burning to evaluate the human health risk. *Environ. Int.* 125, 191–199. <https://doi.org/10.1016/j.envint.2018.11.051>.
- Heacock, M., Kelly, C.B., Asante, K.A., Birnbaum, L.S., Bergman, Å.L., Bruné, M.N., Buka, I., Carpenter, D.O., Chen, A., Huo, X., Kamel, M., Landrigan, P.J., Magalini, F., Diaz-Barriga, F., Neira, M., Omar, M., Pascale, A., Ruchirawat, M., Sly, L., Sly, P.D., van den Berg, M., Suk, W.A., 2016. E-waste and harm to vulnerable populations: a growing global problem. *Environ. Health Perspect.* 124, 550–555. <https://doi.org/10.1289/ehp.1509699>.
- Igharo, G.O., Anetor, J.I., Osibanjo, O.O., Osadolor, H.B., Dike, K.C., 2014. Toxic metal levels in Nigerian electronic waste workers indicate occupational metal toxicity associated with crude electronic waste management practices. *Biokemistri* 26, 107–113.
- Ikhlayel, M., 2018. An integrated approach to establish e-waste management systems for developing countries. *J. Clean. Prod.* 170, 119–130. <https://doi.org/10.1016/j.jclepro.2017.09.137>.
- Islam, M.T., Huda, N., 2019. Material flow analysis (MFA) as a strategic tool in E-waste management: applications, trends and future directions. *J. Environ. Manag.* 244, 344–361. <https://doi.org/10.1016/j.jenvman.2019.05.062>.
- Ismail, H., Hanafiah, M.M., 2021. Evaluation of e-waste management systems in Malaysia using life cycle assessment and material flow analysis. *J. Clean. Prod.* 308, 127358. <https://doi.org/10.1016/j.jclepro.2021.127358>.
- Kahhat, R., Williams, E., 2012. Materials flow analysis of e-waste: domestic flows and exports of used computers from the United States. *Resour. Conserv. Recycl.* 67, 67–74. <https://doi.org/10.1016/j.resconrec.2012.07.008>.
- Kawulich, B.B., 2005. Participant observation as a data collection method. *Forum Qual. Soc. Res.* 6, 1–35. <https://doi.org/10.17169/fqs-6.2.466>.

- Kazancoglu, Y., Ozkan-Ozen, Y.D., Mangla, S.K., Ram, M., 2022. Risk assessment for sustainability in e-waste recycling in circular economy. *Clean Technol. Environ. Policy* 24, 1145–1157. <https://doi.org/10.1007/s10098-020-01901-3>.
- Kumi, E., Hemkhaus, M., Bauer, T., 2019. Money Dey for Borla: Assessment of Ghana's E-Waste Value Chain.
- Kumi, E., Hemkhaus, M., Hibler, S., Boateng, P., von Falkenhausen, I., 2021. Trust Be Key: Exploring Pathways to Formalisation in Ghana's E-Waste Sector.
- Kyere, V.N., 2016. Environmental and Health Impacts of Informal E-waste Recycling in Agbogbloshie, Accra, Ghana: Recommendations for Sustainable Management. Rheinische Friedrich-Wilhelms-Universität, Bonn.
- Lambert, F., Sampson, A., Letitia, T., Desmond, A., Andrea, M., Schleicher, T., 2018. Technical Guidelines on Environmentally Sound E-Waste Management for Collectors, Collection Centers, Transporters, Treatment Facilities and Final Disposal in Ghana.
- Laner, D., Rechberger, H., Astrup, T., 2014. Systematic evaluation of uncertainty in material flow analysis. *J. Ind. Ecol.* 18, 859–870. <https://doi.org/10.1111/jiec.12143>.
- Liebmann, A., 2015. ICT Waste Handling: Regional and Global End-Of-Life Treatment Scenarios for ICT Equipment 79.
- Liu, K., Tan, Q., Yu, J., Wang, M., 2023. A global perspective on e-waste recycling. *Circ. Econ.* 2, 100028 <https://doi.org/10.1016/j.ccc.2023.100028>.
- Maes, T., Preston-Whyte, F., 2022. E-waste it wisely: lessons from Africa. *SN Appl. Sci.* 4 <https://doi.org/10.1007/s42452-022-04962-9>.
- Mairizal, A.Q., Sembada, A.Y., Tse, K.M., Rhamdhani, M.A., 2021. Electronic waste generation, economic values, distribution map, and possible recycling system in Indonesia. *J. Clean. Prod.* 293, 126096 <https://doi.org/10.1016/j.jclepro.2021.126096>.
- Miezah, K., Obiri-Danso, K., Kádár, Z., Fei-Baffoe, B., Mensah, M.Y., 2015. Municipal solid waste characterization and quantification as a measure towards effective waste management in Ghana. *Waste Manag.* 46, 15–27. <https://doi.org/10.1016/j.wasman.2015.09.009>.
- Moeckel, C., Breivik, K., Nøst, T.H., Sankoh, A., Jones, K.C., Sweetman, A., 2020. Soil pollution at a major West African E-waste recycling site: contamination pathways and implications for potential mitigation strategies. *Environ. Int.* 137, 105563 <https://doi.org/10.1016/j.envint.2020.105563>.
- Odeyingbo, O., Nnorom, I., Deubzer, O., 2017. Person in the Port Project - Assessing Import of Used Electrical and Electronic Equipment into Nigeria, vol. 35.
- Oduro-Appiah, K., Scheinberg, A., Mensah, A., Afful, A., Boadu, H.K., de Vries, N., 2017. Assessment of the municipal solid waste management system in Accra, Ghana: a 'Wasteaware' benchmark indicator approach. *Waste Manag. Res.* 35, 1149–1158. <https://doi.org/10.1177/0734242X17727066>.
- Oduro-Kwarteng, S., Anarfi, K.P., Essandoh, H.M.K., 2016. Source separation and recycling potential of municipal solid waste in Ghana. *Manag. Environ. Qual. Int. J.* 27, 210–226. <https://doi.org/10.1108/MEQ-03-2015-0038>.
- Oteng-Ababio, M., 2012. The role of the informal sector in solid waste management in the Gama, Ghana: challenges and opportunities. *Tijdschr. Econ. Soc. Geogr.* 103, 412–425. <https://doi.org/10.1111/j.1467-9663.2011.00690.x>.
- Oteng-Ababio, M., Amankwaa, E.F., Chama, M.A., 2014. The local contours of scavenging for e-waste and higher-valued constituent parts in Accra, Ghana. *Habitat Int.* 43, 163–171. <https://doi.org/10.1016/j.habitatint.2014.03.003>.
- Oteng-Ababio, M., Melara Arguello, J.E., Gabbay, O., 2013. Solid waste management in African cities: sorting the facts from the fads in Accra, Ghana. *Habitat Int.* 39, 96–104. <https://doi.org/10.1016/j.habitatint.2012.10.010>.
- Owusu-Sekyere, K., Batteiger, A., Afobikame, R., Hafner, G., Kranert, M., 2022. Assessing data in the informal e-waste sector: the Agbogbloshie Scrapyard. *Waste Manag.* 139, 158–167. <https://doi.org/10.1016/j.wasman.2021.12.026>.
- Owusu-Twum, M.Y., Kumi-Amoah, G., Heve, W.K., Lente, I., Owusu, S.A., Larbi, L., Amfo-Otu, R., 2022. Electronic waste control and management in Ghana: a critical assessment of the law, perceptions and practices. *Waste Manag. Res.* <https://doi.org/10.1177/0734242X221103939>.
- Pradhan, J.K., Kumar, S., 2014. Informal e-waste recycling: environmental risk assessment of heavy metal contamination in Mandoli industrial area, Delhi, India. *Environ. Sci. Pollut. Res.* 21, 7913–7928. <https://doi.org/10.1007/s11356-014-2713-2>.
- Prakash, S., Manhart, A., Amoyaw-Osei, Y., Agyekum, O.O., 2010. Socio-economic assessment and feasibility study on sustainable e-waste management in Ghana. In: Öko-Institut e.V. - Institute of Applied Ecology. Freiburg/Darmstadt/Berlin.
- Republic of Ghana, 2016. Hazardous and Electronic Waste Control and Management Act 917. BMJ Glob. Heal.
- Scheinberg, A., Nescic, J., Savain, R., Luppi, P., Sinnott, P., Petean, F., Pop, F., 2016. From collision to collaboration - integrating informal recyclers and re-use operators in Europe: a review. *Waste Manag. Res.* 34, 820–839. <https://doi.org/10.1177/0734242X16657608>.
- Schluep, M., Terekhova, T., Manhart, A., Muller, E., Rochat, D., Osibanjo, O., 2012. Where are WEEE in Africa? *Electron. Goes green* 2012+, 09-12 September 2012, IEEE. Jt. Int. Conf. Exhib. Proc. ISBN:978-3-8396-0439-7.
- Sepúlveda, A., Schluep, M., Renaud, F.G., Streicher, M., Kuehr, R., Hagelüken, C., Gerecke, A.C., 2010. A review of the environmental fate and effects of hazardous substances released from electrical and electronic equipments during recycling: examples from China and India. *Environ. Impact Assess. Rev.* 30, 28–41. <https://doi.org/10.1016/j.eiar.2009.04.001>.
- Sevigné-Itoiz, E., Gasol, C.M., Rieradevall, J., Gabarrell, X., 2015. Methodology of supporting decision-making of waste management with material flow analysis (MFA) and consequential life cycle assessment (CLCA): case study of waste paper recycling. *J. Clean. Prod.* 105, 253–262. <https://doi.org/10.1016/j.jclepro.2014.07.026>.
- Shevchenko, T., Laitala, K., Danko, Y., 2019. Understanding consumer e-waste recycling behavior: introducing a new economic incentive to increase the collection rates. *Sustain. Times* 11. <https://doi.org/10.3390/su11092656>.
- Shittu, O.S., Williams, I.D., Shaw, P.J., 2021. Global E-waste management: can WEEE make a difference? A review of e-waste trends, legislation, contemporary issues and future challenges. *Waste Manag.* <https://doi.org/10.1016/j.wasman.2020.10.016>.
- Soyer, A., Bozdog, E., Kadaifci, C., Asan, U., Serdarasan, S., 2023. A hesitant approach to sustainable supply chain risk assessment. *J. Clean. Prod.* 418, 138103 <https://doi.org/10.1016/j.jclepro.2023.138103>.
- Streicher-Porte, M., Widmer, R., Jain, A., Bader, H.P., Scheidegger, R., Kytzia, S., 2005. Key drivers of the e-waste recycling system: assessing and modelling e-waste processing in the informal sector in Delhi. *Environ. Impact Assess. Rev.* 25, 472–491. <https://doi.org/10.1016/j.eiar.2005.04.004>.
- Tsydenova, O., Bengtsson, M., 2011. Chemical hazards associated with treatment of waste electrical and electronic equipment. *Waste Manag.* 31, 45–58. <https://doi.org/10.1016/j.wasman.2010.08.014>.
- UN DESA, 2023. The Sustainable Development Goals Report 2023. UN DESA. © UN DESA., New York.
- UNEP, 2018. Africa Waste Management Outlook. United Nations Environment Programme, Nairobi, Kenya.
- Van Yken, J., Boxall, N.J., Cheng, K.Y., Nikoloski, A.N., Moheimani, N.R., Kaksonen, A.H., 2021. E-waste recycling and resource recovery: a review on technologies, barriers and enablers with a focus on oceania. *Metals* 11. <https://doi.org/10.3390/met11081313>.
- Wang, F., Huisman, J., Meskers, C.E.M., Schluep, M., Stevels, A., Hagelüken, C., 2020. The Best-of-2-Worlds philosophy : developing local dismantling and global infrastructure network for sustainable e-waste treatment in emerging economies. *Waste Manag.* 32, 2134–2146. <https://doi.org/10.1016/j.wasman.2012.03.029>.
- Wang, F., Huisman, J., Stevels, A., Baldé, C.P., 2013. Enhancing e-waste estimates: improving data quality by multivariate Input-Output Analysis. *Waste Manag.* 33, 2397–2407. <https://doi.org/10.1016/j.wasman.2013.07.005>.
- Wang, L., Cheng, Y., Wang, Z., 2022. Risk management in sustainable supply chain: a knowledge map towards intellectual structure, logic diagram, and conceptual model. *Environ. Sci. Pollut. Res.* 29, 66041–66067. <https://doi.org/10.1007/s11356-022-22255-x>.
- Wilson, D.C., Velis, C., Cheeseman, C., 2006. Role of informal sector recycling in waste management in developing countries. *Habitat Int.* 30, 797–808. <https://doi.org/10.1016/j.habitatint.2005.09.005>.
- Wilson, D.C., Velis, C.A., Rodic, L., 2013. Integrated sustainable waste management in developing countries. In: Proceedings of the Institution of Civil Engineers: Waste and Resource Management. Proc. Inst. Civ. Eng. Waste Resour. Manag., pp. 52–68.
- Wu, Q., Leung, J.Y.S., Geng, X., Chen, S., Huang, X., Li, H., Huang, Z., Zhu, L., Chen, J., Lu, Y., 2015. Heavy metal contamination of soil and water in the vicinity of an abandoned e-waste recycling site: implications for dissemination of heavy metals. *Sci. Total Environ.* 506 (507), 217–225. <https://doi.org/10.1016/j.scitotenv.2014.10.121>.
- Zeng, X., Xu, X., Zheng, X., Reponen, T., Chen, A., Huo, X., 2016. Heavy metals in PM2.5 and in blood, and children's respiratory symptoms and asthma from an e-waste recycling area. *Environ. Pollut.* 210, 346–353. <https://doi.org/10.1016/j.envpol.2016.01.025>.
- Zhao, W., Ding, L., Gu, X., Luo, J., Liu, Y., Guo, L., Shi, Y., Huang, T., Cheng, S., 2015. Levels and ecological risk assessment of metals in soils from a typical e-waste recycling region in southeast China. *Ecotoxicology* 24, 1947. <https://doi.org/10.1007/s10646-015-1532-7>. –1960.